



Sûreté des Procédés Industriels

Industrial Range

P Series

Pressure switches and
Temperature switches



Characteristics*

- Gauge, absolute or differential pressure control
- Temperature control: direct bulb or through capillary
- Electrical contact or pneumatic signal output
- Protection for areas involving an explosion risk (ATEX)
 - Explosion-proof enclosure
 - Intrinsic safety
 - Increased safety
 - Explosion-proof contact
- Protection of pressure equipment against exceeding allowable limits (PED)
 - Pressure
 - Temperature

* depending on the models

APPLICATIONS

- Industrial model
- Homogeneous, proven range
- Numerous qualifications (marine, energy, etc.)
- Extremely adaptable
- Made in France



Contents

Introduction	3
Applications	
Working principle	
Construction	4
Type of housing	
Type of sensing element and connection	
Operating temperature limits	
Ambient operating temperature limits	
Storage temperature	
Reproducibility	
Recommendations	
Equipment designed for EXplosive ATmospheres (ATEX)	5
Intrinsic safety	
Increased safety	
Explosion-proof safety	
Electrical or pneumatic functions	6
Electrical contact	
Electrical function	
Pneumatic function	
Code numbers	8
Gauge pressure switches: ranges and dead bands	10
Diaphragm-actuated gauge pressure switches	
Bellows-actuated gauge pressure switches	
Gauge (continued) and differential pressure switches: ranges and dead bands	11
Bourdon tube pressure switches	
Diaphragm-actuated differential pressure switches	
Bellows-actuated differential pressure switches	
Temperature switches: ranges and dead bands	12
Direct bulb temperature switches (vapour pressure)	
Bulb and capillary temperature switches (vapour pressure)	
Bulb design and capillary length	
Specific features associated with mounting temperature switches	13
Immersion pockets (mechanically welded) with capillary cable gland	
Capillary protection	
Capillary cable gland	
Dimensional drawings	14
Housing assemblies	
Sensor assemblies	
Certifications and qualifications	15

Note:
Subject to modifications due to technical advances

Introduction

GEORGIN P Series PRESSURE SWITCHES and TEMPERATURE SWITCHES offer an extensive range of equipment suitable for the harshest operating conditions. The series is a justified choice whenever precision and reliability are necessary criteria.

APPLICATIONS

- thermal or nuclear energy generation
- chemicals, petrochemicals, fertilisers
- textile industry, plastic materials
- diesel engines, pumps and compressors
- steam circuits, furnaces and burners, autoclaves
- metallurgy, steelmaking
- ambience control and climatic treatment
- gas, steam or hydraulic turbines
- shipbuilding for merchant or military navy
- glass industry

WORKING PRINCIPLE

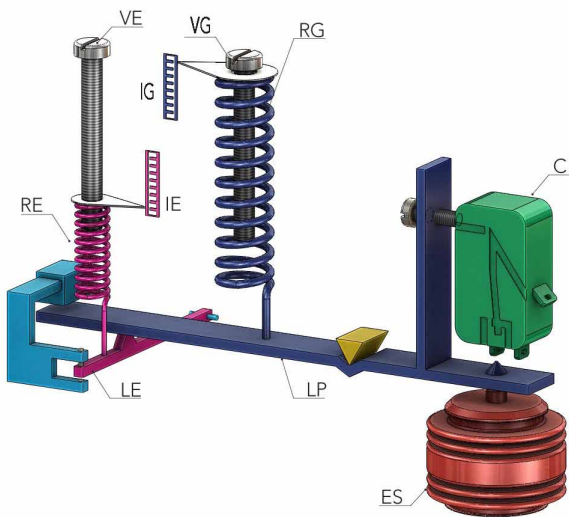

- VG: Range adjustment screw
- RG: Range spring
- IG: Range index
- IE: Dead band or offset index
- RE: Dead band or offset spring
- VE: Dead band or offset adjustment screw
- ES: Sensing element
- LP: Flexible arm
- LE: Dead band arm
- C: Switch

The pressure or temperature is applied to the sensing element (SE), whose position then changes, acting on the flexible arm (FA). The force produced in this way is balanced by the spring (RS). This is how the setpoint is adjusted. As the set point is approached, the change in forces disturbs the balance and acts on the contact.

A second spring (RE) acting on the end of the flexible arm (LP) increases the deviation of the switch(es). The force produced by the dead band spring is adjustable, and is used to offset the two contacts in the case of differential functions.

NOTE: The pressure switch and temperature switch scales indicated in our catalogue are values for a set point to lower the pressure or temperature.

Construction

TYPES OF HOUSINGS

- Standard housing: zamak, epoxy paint coating
- Explosion-proof housing (RTPE): AS7G aluminium, epoxy paint coating

316 stainless steel external screws and fittings

IP 66 (IP68 available as an option)

IP 56 (IP66 available as an option) for diaphragm-actuated gauge pressure switch in ML, MPB, MABV, MJBV type standard housing as per EN 60 529 (IEC 529)

External earth terminal

Inner graduated scale with viewing window

A stainless steel identification plate is fitted on an all stainless steel explosion-proof type instruments and on increased safety instruments.

Options:

External lead sealing kit

Stainless steel identification plate for standard instruments and intrinsic safety instruments

Factory setting and plumbing

Respirator to limit condensation phenomena (IP 56) in standard housing

Fixing bracket or 2" mounting kit

TYPE OF SENSING ELEMENT AND PROCESS CONNECTION

Bellows-actuated technology offers high repeatability. It is recommended for stable processes, not subject to pulses or pressure surges. Bellows are available in bronze or 316L/1.4404 stainless steel versions.

Diaphragm-actuated technology is suitable for meeting two constraints:

- processes with pulsating phenomena or subject to pressure surges
- low or very low pressure control

The material used for the diaphragms will be NBR (such as Perbunan®) as standard, or FKM (such as Viton®) or Ethylene-Propylene.

The flanges will be made of 304L/1.4307 stainless steel for (D)ML, (D)MJBV, in zamak for (D)MPB and 316L stainless steel for PA.

The 316L stainless steel Bourdon tube will be used for very high pressure control up to 1000 bar.

Types of connections:

- G½" as per NF E03-005-1/EN ISO 228-1 as standard
- G¼" M as per NF E03-005-1/EN ISO 228-1 for diaphragm-actuated pressure switches except for (D)ML model
- NPT connector as per NF E 03-601

Other connector types available on request.

Depending on the type and range, the instruments may be equipped with separators with or without capillary.

OPERATING TEMPERATURE LIMITS (PRESSURE SENSING ELEMENT)

Stainless steel bellows: +100°C	-40	to	+150°C	NRB diaphragm:	-20	to	+100°C
Stainless steel tube: +120°C	-40	to	+150°C	EP diaphragm:	-40	to	+100°C
				FKM diaphragm:	-0	to	+150°C

The minimum or maximum temperatures should not be permanent. Contact us for further information.

AMBIENT OPERATING TEMPERATURE LIMITS (HOUSING)

STORAGE TEMPERATURE

-20 to +70°C - others on request.

For temperature switches from the C, G and M ranges: min. 55°C and BA range: min. 55°C.

REPRODUCIBILITY

no more than ±1% of the measurement range at constant cycle and temperature

Greater than ±1% of the measurement range at constant cycle and temperature for the reduced-range sensors and for the diaphragm-actuated instruments with a ≤40 mbar scale.

RECOMMENDATIONS

For all P series equipment, refer to the operating and maintenance manual FU-P-EN.

For ATEX equipment, refer to the ATEX instruction manual: FI-P-EN.



Equipment designed for EXplosive ATmospheres (ATEX)

The tables below enable you to ascertain the product certification according to the protection index (IP66 except for ML, MPB, MABV, MJBV which are IP56 unless specially requested otherwise) and the required installation area.

INTRINSIC SAFETY

Principle: gold-plated contact for low current to be associated with an I.S. interface (see fc-rdn-eng)



Housing: standard

Protective enclosure	IP66	IP56
Markings	CE 0081  II 1GD Exia IIC T6 - Ex iaD 20	CE 0081  II 1G/3D Exia IIC T6 - Ex iaD 22
Installation areas	0/1/2 for gas groups IIA, IIB, IIC 20 / 21 / 22 for dust	0/1/2 for gas groups IIA, IIB, IIC 22 for non-conductive dust
Equipment category	1GD	1G/3D (non-conductive dust)
Maximum surface temperature	80°C	
CE type examination statement Type examination statement	LCIE 01 ATEX 6008X	LCIE 02 ATEX 6008X LCIE 08 ATEX 6057X (voluntary statement)

INCREASED SAFETY

Principle: explosion-proof contact "d" - terminal block + increased safety cable gland "e"

Housing: standard

Protective enclosure	IP66	IP56
Markings	CE 0081  II 2GD Exde IIC T6 - Ex tD A 21	CE 0081  II 2G/3D Exde IIC T6 - Ex tD A 22
Installation areas	1/2 for gas groups IIA, IIB, IIC 21 / 22 for dust	1/2 for gas groups IIA, IIB, IIC 22 for non-conductive dust
Equipment category	2GD	2G/3D (non-conductive dust)
Maximum surface temperature	80°C	
CE type examination statement Type examination statement	LCIE 02 ATEX 6161X	LCIE 02 ATEX 6161X LCIE 08 ATEX 6057X (voluntary statement)

EXPLOSION-PROOF SAFETY



Principle: explosion-proof unit "d"

Housing: type RTPE

Protective enclosure	IP66	
Markings	CE 0081  II 2GD Ex d IIC T6 - Ex tD A21 (with or without line resistors)	
Installation areas	1/2 for gas groups IIA, IIB, IIC 21 / 22 for dust	
Equipment category	2GD	
Maximum surface temperature	80°C	
CE type examination statement	LCIE 01 ATEX 6071X	

Principle: explosion-proof contact "d" with moulded cable output

Housing: standard

Protective enclosure	IP66	IP56
Markings	CE 0081  II 2GD Exd IIC T6 - Ex tD A21	CE 0081  II 2G/3D Exd IIC T6 - Ex tD A22
Installation areas	1/2 for gas groups IIA, IIB, IIC 21 / 22 for dust	1/2 for gas groups IIA, IIB, IIC 22 for non-conductive dust
Equipment category	2GD	2G/3D (non-conductive dust)
Maximum surface temperature	80°C	
CE type examination statement Type examination statement	LCIE 01 ATEX 6071X	LCIE 01 ATEX 6071X LCIE 08 ATEX 6057X (voluntary statement)

CONSTRUCTIONAL SAFETY (PNEUMATIC MODELS)

Principle: constructional safety

Housing: standard

Protective enclosure	IP66	IP56
Markings	II 2GD c IIC Tx (-20°C<Ta<60°C) IP66 T...°C	II 2G 3D c IIC Tx (-20°C<Ta<60°C) IP56 T...°C
Installation areas	1/2 for gas groups IIA, IIB, IIC 21 / 22 for dust	1/2 for gas groups IIA, IIB, IIC 22 for non-conductive dust
Equipment category	2GD	2G 3D
Technical file c	0610 - LCIE 10 AR 046 NM	

Electrical or pneumatic functions

ELECTRICAL CONTACT

The electrical contacts used by Georgin are SPDT type.
At rest, contact is established between C-NC.

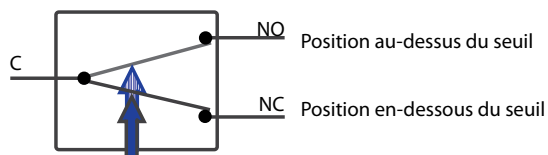

According to the type of action (opening or closure of the electrical circuit), the electrical connection is made on the terminal block between C-NC or C-NO.

ELECTRICAL FUNCTIONS

		Fixed dead band ⁽¹⁾	Adjustable dead band ⁽²⁾
1 Change-over ^{(1) (2)} (SPDT)	Standard	4, 4D	6, 6 D, 6 T, 6V
	Tight dead band	10, 10 D, 10 T, 16, 16 D	-
	N2 hermetically-sealed	-	96
	Tight N2 hermetically-sealed dead band	98	-
	Ex de safety	-	62
	Tight dead band Ex safety	60	-
	Ex d explosion-proof	-	62C
	Ex d explosion-proof tight dead band	60C	-
Manual reset (5)	18, 18D (at max.), 20, 20D (at min.)	-	
2 SPDT (exp) (acting together)	Standard	44, 44 D	34, 34 D, 34 T, 34V
	Tight dead band	30, 30 D, 30 T, 36, 36 D	-
	N2 hermetically-sealed	-	106
	Tight N2 hermetically-sealed dead band	108	-
	Ex de safety	-	162
	Tight dead band Ex safety	160	-
	Ex d explosion-proof	-	162C
	Ex d explosion-proof tight dead band	160C	-
Adjustable lagging			
2 SPDT (exp) (two steps)	Standard	46, 46 D, 54, 54 D, 54 T, 54V	
	Tight dead band	50, 50D, 50T, 56, 56D	
	N2 hermetically-sealed	116	
	Tight N2 hermetically-sealed dead band	118	
	Ex de safety	172	
	Tight dead band Ex safety	170	
	Ex d explosion-proof	172C	
	Ex d explosion-proof tight dead band	170C	

(1). Single fixed dead band electrical operation:

Microswitch "only". Each type of microswitch has its own characteristics, as indicated in the catalogue.

Models: 4, 4D, 10, 10D, 16, 16D, 98, 60, 60C, ...

(2). Single adjustable dead band electrical operation:

Microswitch combined with a spring (RE) to increase the microswitch dead band value in a given range (refer to the dead band table in the catalogue)

The trigger value of the upper threshold can be offset using the RE. This action has no effect on the lower threshold.

Models: 6, 6V, 96, 62, 62C, ...

(3). Electrical operation with two simultaneous contacts:

Combination of two single functions set to act at the same time, either upwards or downwards.

The dead band of a simultaneous function is greater than that of a single function.

Fixed dead band models: 44, 30, 36, 108, 160, 160C, ... Adjustable dead band models: 34, 34V, 106, 162, 162C, ...

(4). Electrical function with two offset contacts:

Combination of two single functions adjusted to act with a gap between. The spring (RE) is used to adjust the gap between the interlocking of the switches.

Models: 46, 54, 54V, 50, 56, 116, 118, 172, 172C, 170, 170C, ...

(5). Electrical operation with manual reset:

Once triggered, the switch returns to its initial position only if you press the button located on the side of the housing and only if the pressure or temperature has dropped (type 18 max. cut-off device) or risen (type 20 min. cut-off device) beyond the setpoint.

Remarks:

The electrical functions 60C, 62C, 160C, 162C, 170C and 172C consist of explosion-proof contacts (Ex) equipped with 1 m of pre-assembled cable (3 or 5 m available as an option) which must be connected to an approved terminal block.

The electrical functions 4D/6D/34D/54D, 10D, 16D, 60D, 62D consist of gold-plated contacts, suitable for use at low levels for PLC and also for intrinsic safety instruments. The contacts 4, 6, 34, 54 are tropicalised as standard.

Electrical or pneumatic functions

Maximum breaking capacity (resistive load)

Contact no.	AC		DC	
	Current (A)	Voltage (V)	Current (A)	Voltage (V)
4/44	10A	240V	0.5A	110V
6/18/20/34/54	5A	240V	0.5A	130V
10/16/30/36/50/56	2A	240V	1A	130V
96/106/116/98/108/118	2.5A	240V	1A	130V
92/102/112	4A	115V	0.3A	110V
62/62C/162/162C/172/172C	5A	240V	0.4A	250V
60/60C/160/160C/170/170C	7A	240V	0.25A	250V 6V
4D/44D/46D	-	-	1mA / 100mA	4V / 30V
6D/34D/54D/10D/30D/50D/16D/36D/56D	-	-	10mA / 100mA	6V / 24V
18D/20D	-	-	10mA / 50mA	6V / 30V

Cable inlets

The instruments (except explosion-proof housings) are supplied with one or two M20 cable glands

- For Ø 7.5 to 13 mm cable (standard instrument)
- For Ø 8 to 13 mm cable (S.I. and Ex de instrument)

Other cable gland models are available on request.

The instrument can also be supplied without cable inlets. In that case, the instrument is supplied with an M20 thread as standard.

Explosion-proof housings

The housing is supplied as standard with a type 3/4" NPT cable inlet.

Cable glands are available as an option. The choice of cable gland directly affects the certification, and could lead to the equipment being declassified. Refer to the ATEX instruction sheet.

Ensure that the cable gland has been tightened sufficiently and add 'drip protection' to the cable in order to preserve the instrument's IP level.

PNEUMATIC FUNCTION

The instruments can be equipped with a Normally Open (NO) or Normally Closed (NC) pneumatic function using a poppet or spool valve.

Georgin offers single pneumatic functions.

The supply fittings are M5, 1/4, or 1/8 gas threaded according to the type of function and/or the model.

According to the type of cell, the control pressure will be:

- As standard: 1.5 to 8 bar (poppet design <> with a residual leak of 10 to 52 l/h depending on the control pressure).
- On request: 0 to 10 bar (poppet design <> without leak).

The control fluid must be compatible with the ISO-VG 10 standard (air, nitrogen, etc.).

Maximum allowable filtration 5 µm.

The standard materials for the cell body are polyamide, brass, and/or aluminium. The seals are made of NBR (other types on request).

For certain models, exhaust is via open cable gland or screw terminal (mandatory for ATEX models).

The control pressure applied to the unit affects the dead band: the lower the supply pressure, the smaller the dead band, and vice-versa.

POTENTIOMETRIC FUNCTION

Resistive-type output signal depending on the dead band in a range of 135 Ohms or 220 Ohms.

At rest, the pneumatic function is set as follows:

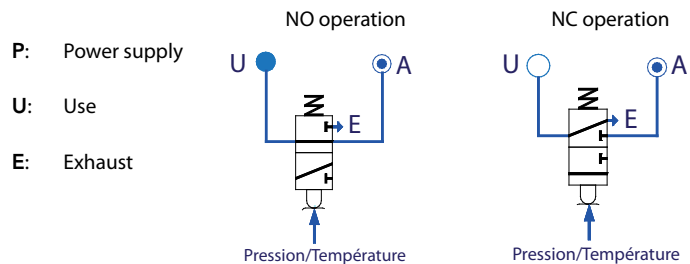

Pneumatic function type	Reference
normally open using poppet valve	YNO
normally closed using poppet valve	YNF
normally open using spool valve	YT1
normally closed using spool valve	YT3

Instrument type		pages 5 to 7
PV	Bellows-actuated absolute pressure switch	
ML MPB MABV MJBV PA (S)	Diaphragm-actuated gauge pressure switch	
P PHB	Bellows-actuated gauge pressure switch	
PL	Bourdon tube gauge pressure switch	
DML DMPB DMKBV DMABV DMJBV	Diaphragm-actuated differential pressure switch	
DPB DPHB	Bellows-actuated differential pressure switch	
B BA	Direct bulb temperature switch	
C	Bulb and capillary temperature switch	

Electrical function type		pages 3 and 4
4 / 4D 98 10 / 10D 16 / 16D / 60 / 60C	Single fixed dead band electrical operation	
18 / 18D 20 / 20D	Single electrical operation with manual reset	
6 / 6D 96 62 / 62C	Single adjustable dead band electrical operation	
44 / 44D 30 / 30D 36 / 36D 108 160 / 160C	Fixed dead band electrical function with two simultaneous contacts	
34 / 34D 106 162 / 162C	Adjustable dead band electrical function with two simultaneous contacts	
54 / 54D / 54V 50 / 50D 56 / 56D 116/118 172 / 172C 170 / 170C	Electrical operation with two offset contacts	
YT1 / YT3 YNO / YNF	Pneumatic function	

DEAD BAND TABLE READING GUIDE

Applicable to tables on pages 10/11/12

Example on P . PX type pressure switch

Type	Range	1 SPDT				2 SPDT				max. dead band \geq	P max.								
		fixed dead band \leq										adjustable dead band \leq							
		16	60	98	108	6	62	96	106										
	bar	bar								bar									
		B	H	B	H	B	H	B	H	B	H	B	H	B	H	B	H		
P . PX	0.5 to 10	0.02	0.025	0.13	0.18	0.26	0.34	0.4	0.5	0.22	0.3	0.38	0.5	0.33	0.43	0.58	0.65	2	15

A P . PX denotes a P series gauge pressure switch. For the sensitive element of P . PX with stainless steel bellows, the maximum pressure is 15 bar

Its scale is 0.5 to 10 bar, which means that a setpoint can be adjusted **when the pressure drops to** between 0.5 and 10 bar. Please note that the setting range for a pressure rise setpoint is dependent on the associated microswitch.

Note: the adjustment plate is indicative (accuracy +/-2 mm) and calibrated to the setpoint at the drop in pressure.

The figure opposite represents the switching operations of the electrical microswitch for an instrument adjusted to the drop in pressure or temperature.

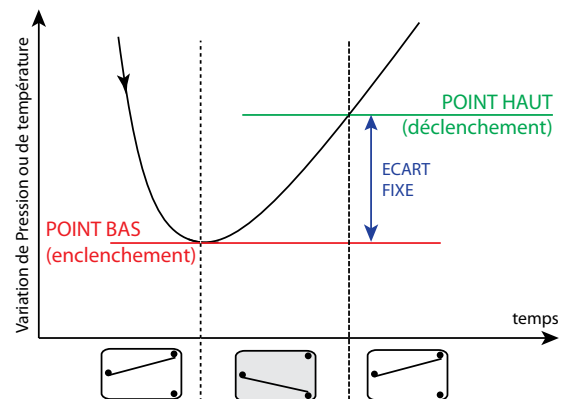

DEAD BANDS ARE CALCULATED AS FOLLOWS:

PX

RTPE

Range and qualification or parts in contact with the fluid

The range information is detailed in the next three pages.

The information "X" denotes, according to the type of instrument, that the connector, bellows, Bourdon tube and the flange of the diaphragm-actuated instrument or the the thermostatic element are made of stainless steel.

In addition to the reference, you still have to specify for a pressure switch:

- The type of connector (1/2" GM, 1/4" NPTF, mounting on separator, etc.)
 - The diaphragm material if applicable (Perbunan, Viton or E.P.)
- If a treatment such as degreasing, passivation or a helium test is to be envisaged, please specify this.

For a temperature switch:

- The type of bulb
 - Its dimensions
- and if applicable, the type of capillary, its length and protection.

Specific feature(s)

Standard housing

Explosion-proof housing

RTPE

Cannot be associated with the electrical functions

60(C), 62(C),
160(C), 162(C),
170(C), 172(C)

nor the pneumatic functions

To meet the diversity of constraints in your processes, Georgin has one of the most extensive ranges of electromechanical and electropneumatic security solutions in the world.

Because our product range is subject to on-going development and so as not to impact the safety of your installations, this document enables you to define your overall reference. We shall confirm this with our item code.

■ Fixed dead band electrical operation

	4 / 4D	10 / 10D	16 / 16D	60 / 60C	98	30	36	160/160C
fixed dead band	~ min. dead band of a function 6	~ dead band of a function 16 x1.6	0.02 ... 0.025 bar	0.13 ... 0.18 bar	0.26 ... 0.34 bar	~ dead band of a function 10 x1.8	~ dead band of a function 16 x2	~ dead band of a function 60 x1.9

■ Adjustable dead band electrical operation

	Single functions			Dual functions			
	6/6D	62 / 62C	96	34 / 34D	108	106	162/162C
min. dead band	0.22 ... 0.3 bar	0.38 ... 0.5 bar	0.33 ... 0.34 bar	~ min. dead band of a 6 x1.5	0.4 ... 0.5 bar	0.58 ... 0.65 bar	~ dead band of a 62 x1.5
max. dead band	2 bar						

■ Electrical operation with two offset contacts

	54 / 54D	50/50D	56/56D	170C	172C	116	118
2 nd microswitch	~ min. dead band of a function 6	~ dead band of a 10	~ dead band of a 16	~ dead band of a function 62	~ min. dead band of a function 62	~ min. dead band of a function 96	~ dead band of a 98
1 st microswitch	~ min. dead band of a function 6 x1.5	~ dead band of a 10 x1.8	~ dead band of a 16 x2	~ dead band of a function 60 x1.5	~ min. dead band of a function 62 x1.9	~ min. dead band of a function 106	~ dead band of a 108

Regardless of the dual offset electrical function, the dead band between the first increasing setpoint and the second dropping setpoint must be within the setting range equivalent to the rangeability offered by a function 6, i.e. between 285 mbar and 2 bar. Otherwise, please consult us.

Gauge pressure switches: ranges and dead bands

DIAPHRAGM-ACTUATED GAUGE PRESSURE SWITCHES ■

Type	Range	1 SPDT				2 SPDT				1 SPDT				2 SPDT				Max. dead band ≥	P max.		
		fixed dead band ≤								adjustable dead band ≤											
		16		60		98		108		6		62		96		106					
mbar		mbar																mbar	bar		
		B	H	B	H	B	H	B	H	B	H	B	H	B	H	B	H	B	H		
ML . EX	- 50 to 0	0.35	0.45	1.7	2.1	4	5	5.5	6.5	4	5	4	5	5	6	7	8	25	0.3		
ML . FX	- 2 to + 10	0.15	0.25	1	1.3	2	2.5	3.5	4.5	2.1	2.7	2.3	3	3.5	4	4.5	6.5	5	0.3		
ML . GX	- 5 to + 50	0.25	0.35	1.6	2.3	3	4	4	5	3.5	5.2	3.6	5.2	4	5	5	7.5	15	0.3		
ML . HX	- 5 to + 100	0.3	0.4	2.3	3.5	4	5.5	5	6.5	5	7.7	5	7.5	5	6.5	6	8	25	0.3		
MPB . E ●	- 50 to + 10	0.8	0.8	4.2	4.2	8	8	11	14	9	9	10	10	10	13	14	16	35	3		
MPB . F ●■	- 2 to + 10	0.5	0.5	2.9	2.9	7	9	8	11	6	6	7	7	7	9	10	13	30	3		
MPB . G ●▲	- 2 to + 50	0.8	0.8	4.2	4.2	9	11	12	14	9	9	10	10	10	12	15	18	35	3		
MPB . H ●	- 2 to + 170	1.1	1.1	4.6	4.6	11	13	14	16	9	11	10	12	12	14	18	20	80	3		
MPB . M ●	0 to 1500	2.5	2.5	25	25	38	38	50	65	50	55	56	62	40	70	60	80	350	4		
MABV . GX	- 5 to + 20	1	1	2.3	2.9	4.5	4.5	8	11	3.5	4	6	7	7	7	9.5	14	15	50		
MABV . LX	0 to 150	1	1.5	5.2	7	7	11	9	13	7	10	11.5	17	8	15	10	18	100	50		
MABV . MX	0 to 500	1.5	2	12.8	17.4	19	24	22	29	17	22	28	36	20	26	24	31	100	50		
MJBV . MX	0 to 700	4	5	23.2	35	35	50	40	60	30	50	51	85	40	60	50	70	400	70		
MJBV . NX	0 to 2000	5	6	29	70	45	90	50	120	40	100	67.5	165	50	120	75	140	400	70		
MJBV . K X	0 to 3000	7	8	46.4	116	60	155	80	190	60	160	96	270	80	200	100	220	400	70		
		bar																		Pulses or transient pressure surge	
PA . KX	- 0.8 to 3.5	0.05	0.05	0.16	0.41	0.23	0.55	0.3	0.66	0.22	0.55	0.36	0.9	0.28	0.66	0.45	0.77	3	● 80		
PA . PX	0.5 to 10	0.035	0.1	0.19	0.52	0.27	0.55	0.39	0.72	0.26	0.72	0.42	1.1	0.36	0.77	0.5	0.88	2	● 80		
PA . QX	3.5 to 25	0.06	0.28	0.46	1.10	0.66	1.2	0.83	1.65	0.66	1.55	1.1	2.5	0.83	2	1.3	2.2	5	● 80		
PA . RX	5 to 50	0.1	0.4	0.87	2.3	1.5	3	1.8	3.5	1.7	3	2	5	2	5	2.4	5.5	10	● 80		

■ For pressure switches equipped with contacts 62/162/172 or 96/106/116, the bottom of the range is 0 mbar.

● Available in 200 bar version - Code PAS (K, P, Q, R) (X).

■ In functions 106, 108, 116, 118 the range of certain instruments can vary slightly.

● MPB instruments are not advised for use on water.

■ Diaphragm instruments (except PA) MUST be mounted vertically (with adjustment screw facing upwards), with the diaphragm horizontal, on an appropriate mount.

BELLOWS-ACTUATED GAUGE PRESSURE SWITCHES

Type	Range	1 SPDT				2 SPDT				1 SPDT				2 SPDT				Max. dead band ≥	P max.
		fixed dead band ≤								adjustable dead band ≤									
		16		60		98		108		6		62		96		106			
bar		bar																bar	
		B	H	B	H	B	H	B	H	B	H	B	H	B	H	B	H	B	H
P . AX	- 1 to 0	0.005	0.007	0.035	0.041	0.05	0.08	0.075	0.120	0.06	0.07	0.08	0.085	0.06	0.1	0.09	0.15	0.250	2
P . LX	0 to 0.2	0.003	0.004	0.026	0.035	0.03	0.035	0.06	0.07	0.03	0.035	0.035	0.045	0.045	0.055	0.08	0.09	0.100	2
P . MX	0 to 1.05	0.004	0.005	0.029	0.041	0.04	0.05	0.06	0.075	0.05	0.06	0.05	0.07	0.055	0.065	0.08	0.09	0.500	2
P . LNX	- 1 to 1	0.010	0.015	0.070	0.081	0.100	0.120	0.130	0.190	0.13	0.15	0.160	0.170	0.120	0.200	0.180	0.300	0.500	8
P . NX	0 to 2	0.008	0.010	0.058	0.070	0.080	0.100	0.120	0.170	0.1	0.13	0.125	0.150	0.100	0.130	0.160	0.200	0.500	8
P . KX	- 1 to 3.5	0.016	0.02	0.14	0.19	0.23	0.25	0.360	0.38	0.32	0.38	0.35	0.4	0.33	0.36	0.55	0.63	3	15
P . PX	0.5 to 10	0.02	0.025	0.15	0.21	0.26	0.34	0.4	0.5	0.44	0.6	0.38	0.5	0.33	0.43	0.58	0.65	2	15
P . KQX	- 0.5 to 6	0.08	0.1	0.52	0.65	0.7	0.8	1	1.2	0.9	1.2	1.1	1.25	1	1.2	1.2	1.6	5	30
P . PQX	0 to 12	0.08	0.1	0.53	0.67	0.75	0.90	1.1	1.35	1	1.3	1.25	1.5	1.1	1.35	1.35	1.8	5	30
P . QX	3.5 to 25	0.08	0.1	0.56	0.7	0.8	1	1.2	1.5	1.1	1.5	1.35	1.7	1.2	1.5	1.5	2	5	30
PHB . RX	5 to 50	0.1	0.14	1.39	1.74	2.1	2.5	2.8	3.5	2.8	3.5	3.4	4.3	2.6	3.6	3.8	4.25	20	100
PHB . SX	10 to 90	0.28	0.45	3.94	4.6	6.6	7.7	7.2	8.3	8	9.5	9.5	11.5	8.2	9.3	8.8	10	20	250
PHB . TX	10 to 200	0.33	0.6	4.64	7	8	10	9	11	11	14	11.5	17	10	13	10.5	14	40	250
PHB . GX ●	0 to 0.4	0.008	0.01																8

● Special execution for autoclaves

BOURDON TUBE PRESSURE SWITCHES

Type	Range	1 SPDT				2 SPDT				1 SPDT				2 SPDT				Max. dead band ≥	P max.
		fixed dead band ≤								adjustable dead band ≤									
		16		60		98		108		6		62		96		106			
bar		bar																bar	
		B	H	B	H	B	H	B	H	B	H	B	H	B	H	B	H	B	H
PL . TX	10 to 200	2.5	2.5	14	14	23	23	45	45	25	25	35	35	35	35	55	55	65	300
PL . VX	25 to 400	3	3	29	29	45	45	75	75	50	50	70	70	60	60	90	90	110	600
PL . WX	50 to 600	4	4	35	35	55	55	80	80	60	60	85	85	65	65	100	100	130	800
PL . YX	100 to 800	6	6	52	52	90	90	135	135	100	100	125	125	120	120	170	170	190	1000

Differential pressure switches: ranges and dead bands

DIAPHRAGM-ACTUATED DIFFERENTIAL PRESSURE SWITCHES

Type	Range ΔP	1 SPDT				2 SPDT				1 SPDT				2 SPDT				Max. dead band ≥	Stat. P min./max. (operating)
		fixed dead band ≤								adjustable dead band ≤									
	16		60		98		108		6		62		96		106		mbar	bar	
	mbar																		
mbar		B	H	B	H	B	H	B	H	B	H	B	H	B	H	B	H		
DML . LX11	0 to 8	0.3		1.7		2.5		4		2.5		4.5		3		5		5	+/- 0.3
DML . LX22	0 to 50	0.5		2.3		3.5		5		3		5		4		6		15	+/- 0.3
DML . LX43	0 to 120	0.6		3		4.5		6		4		7		5		8		25	+/- 0.3
DMPB . M11	2 to 40	1.5		8		15		22		11		18.5		18		30		30	3
DMPB . M33	2 to 400	1.5		12		18		28		15		26		22		35		130	3
DMPB . M54	2 to 900	1.5		17.5		23		35		20		34		28		45		200	3
DMPB . K54	10 to 2000	8		30		45		70		38		70		55		85		400	4
DMPBP . K54	10 to 2000	8		30		45		70		38		70		55		85		400	10
DMKBV . PX11	1 to 20	0.5		2.9		5		7.5		3.6		6.5		6		10		15	10
DMKBV . PX24	1 to 150	0.6		4.5		6.5		10		6		10		8		13		100	10
DMKBV . PX54	1 to 500	0.7		6.5		10		15		9		16		12		20		100	10
DMABV . RX10	1 to 20	0.3		4.6		8		12		6		10		10		15			50
DMABV . RX24	1 to 150	0.5		7		9.5		15		10		17		12		20		100	50
DMABV . RX54	1.5 to 500	1		9.5		12		20		13		22.5		15		25		100	50
DMJBV . RX33	30 to 1000	5		55		65		100		70		120		80		130		400	70
DMJBV . RX43	30 to 2000	6		65		80		120		90		160		100		160		400	70
DMJBV . RX53	30 to 3000	6		90		115		180		120		200		140		220		400	70

- ▲ Certain models can be produced for P static < 0. Please consult us.
- ◆ The DMKBV can only be produced with a "Perbunan" diaphragm.
- Diaphragm instruments MUST be mounted vertically (with adjustment screw facing upwards), with the diaphragm horizontal, on an appropriate mount.
- DMPB instruments are not advised for use on water.
- ◆ DML, DMPB instruments can have a very slight leak in the upper part of the diaphragm every time the state changes.

BELLOWS-ACTUATED DIFFERENTIAL PRESSURE SWITCHES

Type	Range ΔP	1 SPDT				2 SPDT				1 SPDT				2 SPDT				Max. dead band ≥	Stat. P min./max. (operating)
		fixed dead band ≤								adjustable dead band ≤									
	16		60		98		108		6		62		96		106		bar	bar	
	bar																		
bar		B	H	B	H	B	H	B	H	B	H	B	H	B	H	B	H		
DPB . MX12	0.02 to 0.20	0.005		0.03		0.040		0.065		0.04		0.07		0.05		0.075		0.250	-0.5
DPB . MX23	0.03 to 1.05	0.006		0.035		0.060		0.090		0.055		0.10		0.075		0.115		0.450	-0.5
DPB . PX11	0.15 to 0.9	0.025		0.16		0.240		0.360		0.22		0.37		0.3		0.450		0.500	- 1 / 15
DPB . PX22	0.15 to 4	0.03		0.17		0.320		0.480		0.26		0.45		0.4		0.600		1	- 1 / 15
DPB . PX44	0.15 to 9	0.035		0.21		0.360		0.540		0.30		0.54		0.45		0.700		3	- 1 / 15
DPB . QX11	0.5 to 1.5	0.045		0.64		1		1.5		0.9		1.6		1.2		1.8		2	2.5/30
DPB . QX22	0.5 to 7	0.05		0.70		1		1.6		1		1.7		1.3		1.9		2	2.5/30
DPB . QX33	0.5 to 9	0.05		0.75		1.1		1.6		1.1		1.9		1.3		2		4	2.5/30
DPHB . RX11	1 to 6	0.16		1.2		1.8		2.7		1.6		3.2		2.2		3.3		3.5	5/100
DPHB . RX21	1 to 35	0.22		1.3		1.8		3.0		1.7		3.6		2.2		3.6		4.5	5/100
DPHB . TX12	2.5 to 15	0.55		4.6		7		7.5		6.5		11		8.5		13		24	10/250
DPHB . TX23	2.5 to 90	0.6		5.2		7.5		8.0		7		12.5		9		14		45	10/250

Remarks:
 For all differential instruments, the last figure in the reference becomes 0 when associated with a fixed dead band electrical function.
 The "B" columns give the minimum dead band values for the setpoint at the bottom of the range and the min. low pressure at static pressure for a variation in pressure of 5% of the measurement range per minute. The "H" columns, supposed to give the minimum dead band values and setpoint at top of the range, cannot be completed as influenced directly by the static pressure of the process.
 For an explosion-proof housing, the min. dead bands should be multiplied by 1.5.

Important remark for smooth differential pressure switch operation:

To ensure that the contact(s) will change state, the pressure in the HP chamber must be greater than that in the LP chamber. This difference must be greater than the sum of differential pressure (ΔP) + microswitch dead band.

$$HP - LP > \Delta P + e$$

Type	Range ΔP	Adjustable dead band ≤		Max. dead band ≥	Max. static P Min./Max.
		1x SPDT	2x SPDT		
	bar		bar		bar
		B	H	B	H
DPB . QX11	0.5 to 1.5	1.2		1.8	

Example:

For a DPB . QX11 in function 96, the pressure in the HP chamber must be greater than the pressure in the LP chamber by at least:
 P. HP - P. BP > 0.5 + 1.2 bar
 P. HP - P. BP > 1.7 bar

Temperature switches: ranges and dead bands

DIRECT BULB TEMPERATURE SWITCHES (VAPOUR PRESSURE)

As standard, the dimensions of B bulbs are Ø 14 x 120 mm and 46 x 36 mm for BA bulbs

Type	Range	1 SPDT				2 SPDT				1 SPDT				2 SPDT				max. dead band ≥	T max.						
		fixed dead band ≤								adjustable dead band ≤															
	°C	16	60	98	108	6	62	96	106	°C															
		B	H	B	H	B	H	B	H	B	H	B	H	B	H	B	H	B	H	°C					
B.C	-50 to +10	1.0	0.2	6.5	1.2	11.0	2.0	15.5	3.0	14	2.8	15.0	3.0	14.0	3.0	22.0	5.0	20	8	55					
B.G	-20 to +20	0.4	0.2	2.2	1.0	4.5	2.0	7.0	3.0	5.5	2.2	6.0	3.0	5.5	2.5	9.0	4.0	15	7	55					
B.M	0 to 45	0.25	0.15	1.4	0.7	3.0	1.5	4.5	2.1	4.6	1.8	4.5	2.1	4.0	2.0	6.5	3.0	15	7	55					
B.P	25 to 95	0.4	0.15	2.3	0.8	4.7	1.5	7.0	2.2	7.5	2.5	7.0	2.2	6.5	2.5	10.0	3.0	25	9	105					
B.R	45 to 125	0.45	0.15	2.6	0.8	5.5	1.6	8.0	2.3	8.5	2.8	8.0	2.3	7.0	2.0	11.5	3.5	25	9	135					
Special ambient temperature switches																									
BA.M	0 to 45	0.3	0.15	2.2	1.0	3.0	1.5	4.5	2.1	4.6	1.8	4.5	2.1	4.0	2.0	6.5	3.0	15	7	55					
BA.G	-20 to +20	0.4	0.2	1.4	0.7	4.5	2.0	7.0	3.0	5.5	2.2	6.0	3.0	5.5	2.5	9.0	4.0	15	7	55					
BA.P	25 to +70																			70					

BULB AND CAPILLARY TEMPERATURE SWITCHES (VAPOUR PRESSURE)

Differential versions of the temperature switches are also available

Type	Range	1 SPDT				2 SPDT				1 SPDT				2 SPDT				max. dead band ≥	T max. ▲						
		fixed dead band ≤								adjustable dead band ≤															
	°C	16	60	98	108	6	62	96	106	°C															
		B	H	B	H	B	H	B	H	B	H	B	H	B	H	B	H	B	H	°C					
C.C (X)	-50 to +10	1.2	0.2	6.5	1.2	11.0	2.4	15.5	3.0	14.0	2.8	15.0	3.0	14.0	3.5	22.0	5.0	20	8	55					
C.G (X)	-20 to +20	0.4	0.2	2.2	1.0	4.5	2.5	7.0	3.0	5.5	2.2	6.0	3.0	5.5	2.5	9.0	4.0	15	7	55					
C.M (X)	0 to 45	0.25	0.15	1.4	0.7	3.0	1.5	4.5	2.1	4.6	1.8	4.5	2.1	4.0	2.5	6.5	3.5	15	7	55					
C.P (X)	25 to 95	0.6	0.15	2.3	0.8	4.7	1.5	7.0	2.2	7.5	2.5	7.0	2.2	6.0	3.0	10.0	4.0	25	9	105					
C.R (X)	45 to 125	0.6	0.15	2.6	0.8	5.5	4.8	8.0	2.3	8.5	2.8	8.0	2.3	7.0	3.0	11.5	4.0	25	9	135					
C.T (X)	115 to 210	0.6	0.2	3.0	1.0	6.3	2.3	9.5	3.0	10.0	3.5	9.0	3.0	8.0	3.5	13.5	5.0	25	10	225					
C.V (X)	160 to 250	0.6	0.2	2.9	1.1	6.0	2.3	9.0	3.2	9.5	3.7	9.0	3.2	7.5	4.0	13.0	5.0	30	10	260					
C.WX ■	290 to 380	0.55	0.25	3.3	1.5	9.5	6	10.5	4.6	11	5.2	10.0	4.6	12.0	8.0	18.0	11.0	30	20	400					
C.YX	380 to 500	1.0	0.3	5.0	1.7	10.0	3.6	15.0	5.5	15	5.6	14.5	5.5	12.5	4.5	21.0	7.0	45	15	540					
C.ZX	400 to 600	2.5	0.5	14.0	3.0	22.0	7	32.0	7.0	32	8.0	35.0	8.0	30.0	8.5	38.0	11.5	75	18	630					

■ At ambient temperatures <+6°C, the instrument is no longer operational: it will resume normal operation without any damage once the temperature has risen above +6°C (C.WX only).

▲ On request, these max. temperatures can be increased with special ranges. Install probes vertically (capillary output up) or inclined to an angle of 45°. Up to an angle of 75°, please consider the inherent restrictions in respect of the ambient and operating temperatures. For any installations with an angle greater than 75°, please consult us beforehand.

Remarks:

The "L" and "H" columns give the minimum dead band values for the Lowest and Highest set point of the range, for a temperature variation of 0.5°/minute.

The max. dead bands correspond to the adjustable dead band electrical functions. For an explosion-proof housing, the min. dead bands should be multiplied by 1.5.

These values correspond to the optimum and repeated test conditions for a bulb fully immersed without an immersion pocket in a thermostatic bath of which the type and stirring ensure a precise and homogeneous temperature.

BULB DESIGN AND CAPILLARY LENGTH

	2 to 4 metres ■	more than 4 and up to 8 metres	more than 8 and up to 20 metres
C.B (X)	10 x 150 mm in copper train 14 x 150 mm in stainless steel train		
C.C (X) C.G (X) C.M (X) C.P (X)	14 x 150 mm	14 x 236 mm ▲	14 x 336 mm ▲
C.R (X) C.T (X) C.V (X)	10 x 150 mm in copper train 14 x 150 mm in stainless steel train		
C.WX	14 x 150 mm in stainless steel train ■		-

■ Standard capillary length: 2 metres

▲ Other dimensions can be envisaged if the ambient temperature and the adjusted temperature do not overlap.

■ In WX range, 14.150 mm is the one and only length available

Specific features associated with the sensor

Important remark on probe installation

Thermostatic probes must be installed facing down, with the capillary outlet at the top.

The measurement probe must not be placed in a horizontal position. The position of the probe can affect the operation of the temperature switch. This type of probe is intended for vertical use, and is placed lower than the housing.

Any deviation from these conditions can affect the response time and operation of the device.

By design, our temperature switches are filled to allow probe inclination of 45° without affecting operation. Beyond this value, operation is dependent on the temperature value measured in relation to ambient temperature.

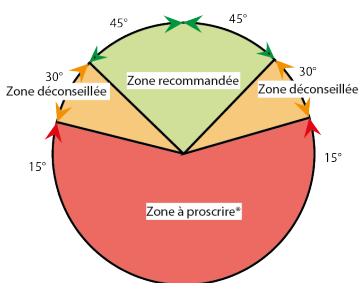

Recommended area: ±45° either side of the vertical axis, bulb down (capillary output up).

Area to be avoided: from 45° to 75°, the operation of the sensor depends on the measured temperature value (Ts) and the ambient temperature (Ta):

Ta > Ts: operation is not affected,

Ta < Ts: operation might be affected,

Ta = Ts: operation is affected.

Prohibited area: Beyond 75°, the operation of the sensor can be significantly affected. This is difficult to predict and depends on several physical parameters. Technical solutions are possible on request (please consult us).

IMMERSION POCKETS (MECHANICALLY WELDED) WITH CAPILLARY CABLE GLAND

For bulb (mm)	A (mm)	B (mm)	C (mm)	D hex w/o flats	E conical	F (mm)	Reference	
							Brass	316L stainless steel
9 x 120	115	16	16	26	G 1/2"	12	GC41	GCX41
10 x 150	145	22	22	29	G 3/4"	◆ 13	GC1	GCX1
10 x 150	145	22	22	29	G 1/2"	◆ 13	GC11	GCX11
▲ 14 x 120	105	22	22	29	G 3/4"	17	GB21	GBX21
14 x 150	145	22	22	29	G 3/4"	17	GC21	GCX21
▲ 14 x 120	105	22	22	29	G 1/2"	17	-	GBX61
14 x 150	145	22	22	29	G 1/2"	17	-	GCX61
14 x 236	232	22	22	29	G 3/4"	17	GC25	GCX25

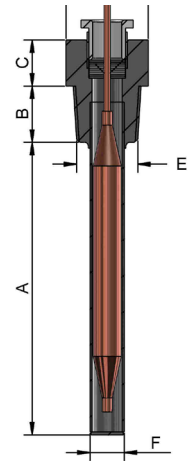

- ▲ For B type
- ◆ Ø14 mm for stainless steel

For NPT process connection, add the suffix "B" to the reference, e.g. GCX21B.

For a longer than standard length, add the suffix "-L" to the reference, e.g. GCX21-L ("A" to be specified).

For a shorter than standard length, add the suffix "-C" to the reference, e.g. GCX21-C ("A" to be specified).

Machined thermometer wells are only supplied when specified by the client.

For bulbs implanted in immersion pockets (except perforated immersion pockets) for gaseous fluid applications, a thermal bridge must be created between the bulb and the immersion pocket using a filler liquid (oil) or a heat-conducting paste.

The technology used by our temperature switches is vapour pressure. This ensures that the measurement will be made only on the bulb, without effect from the temperature in the capillary. As such, for capillary temperature switches, a standard length bulb will be retained even for extra-long bulbs.

CAPILLARY PROTECTION

Gaine flexible inox 304 + gaine vinyl



Gaine flexible inox 304



For all ranges greater than 125°C the vinyl duct length is 10 to 20 cm less than that of the capillary.

CAPILLARY CABLE GLAND (References such as PC** and PCX**)

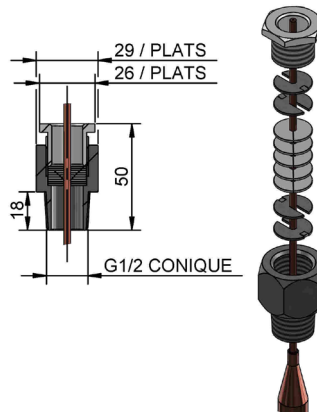

The capillary cable gland helps ensure tightness on the capillary outlet.

This accessory is supplied as standard on the GC and GCX models designated above but is optional on drilled-through designs.

Dimensional drawings

ENSEMBLES BOÎTIER

Boîtier standard

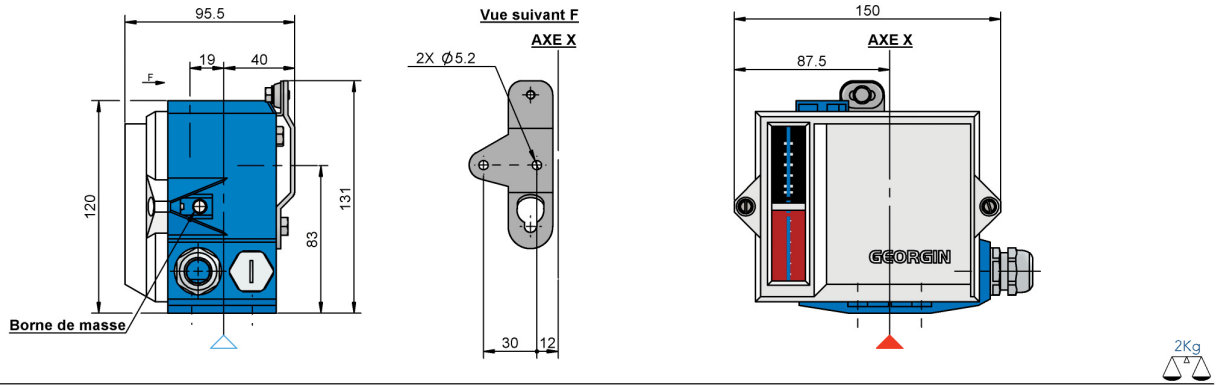

Boîtier antidéflagrant RTPE

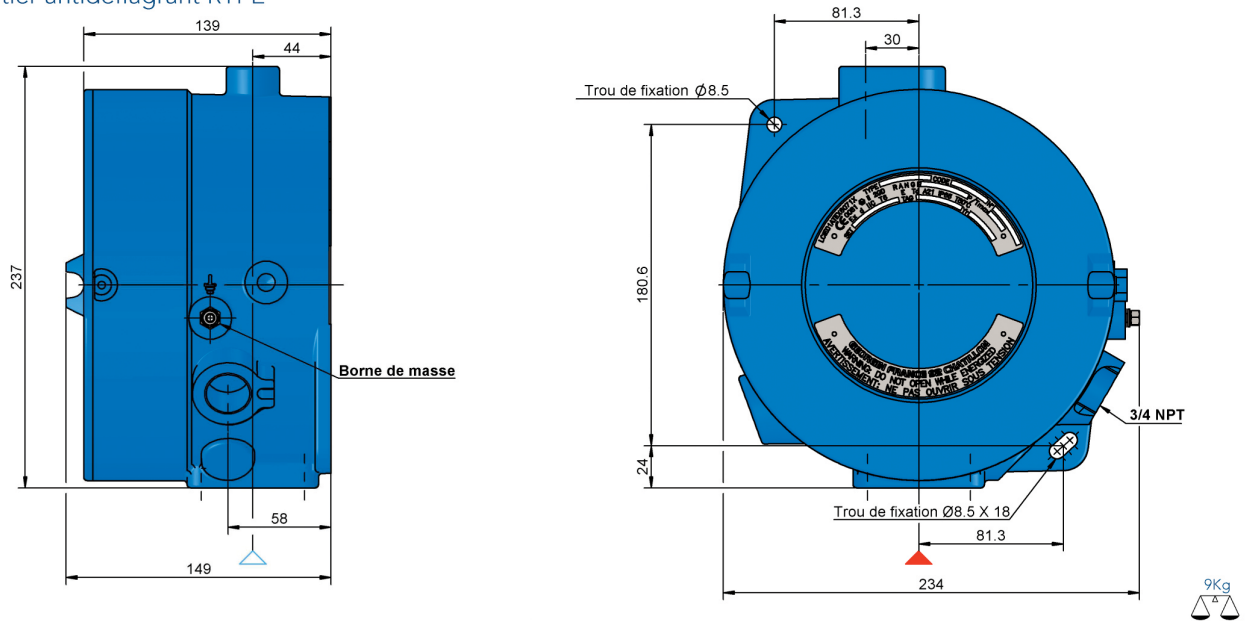

TRAINS THERMOSTATIQUES

C

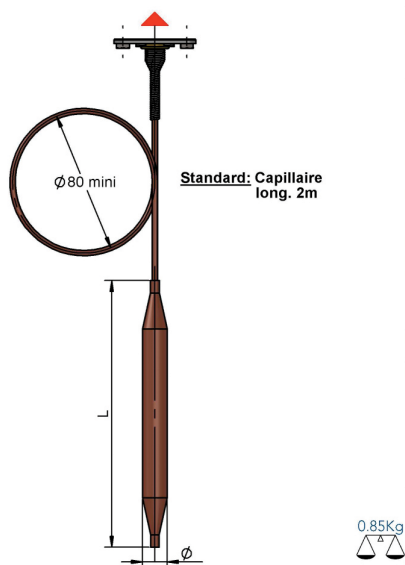

B

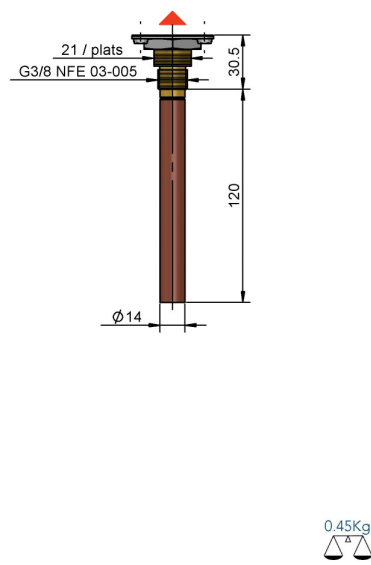

BA



The triangles ▲ (shown on front view) and △ (shown on right-hand view) represent the assembled instrument. 2D or 3D drawings are available as an option to be specified in the order.

REMINDER: Instrument mounting is subject to requirements; please refer to the assembly manual supplied with each instrument beforehand. As such, standard housings are supplied without mounting plates for (D)ML, (D)MABV, (D)MKBV, (D)MJBV and (D)MPB. For secure use, please also consult the instruction notices delivered systematically with the ATEX products.

DIAPHRAGMS

MABV/DMABV/DMKVB

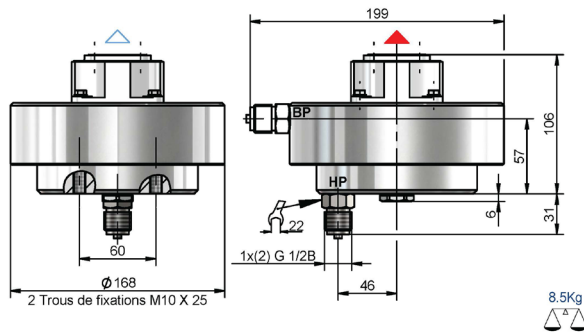

MJBV/DMJBV

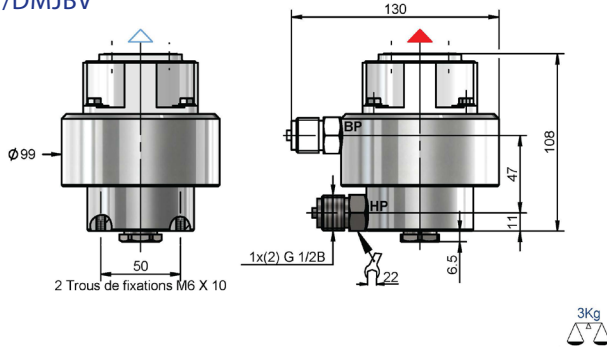

MPB/DMPB

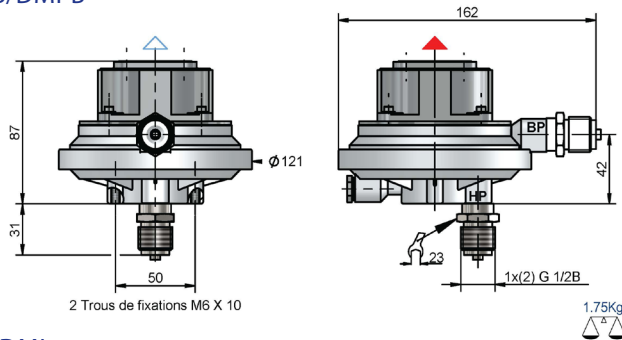

ML/DML

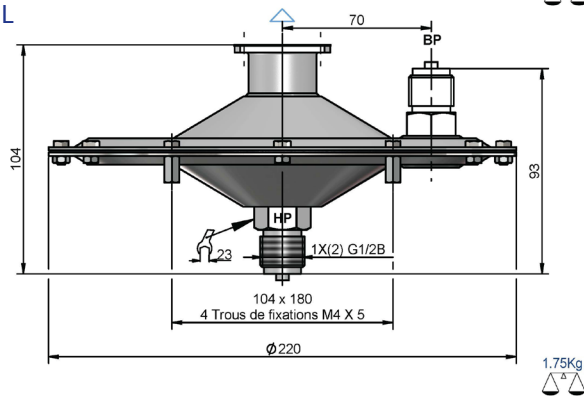

PA/PAS

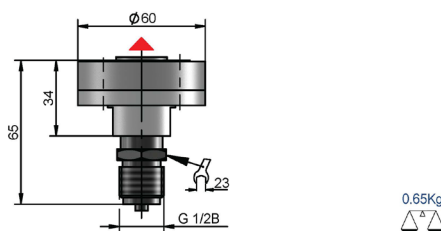

BELLOWS

P - PHB (AX, LX, MX, LNX, NX, GX)

P - PHB (KX, PX, QX, RX, SX, TX)

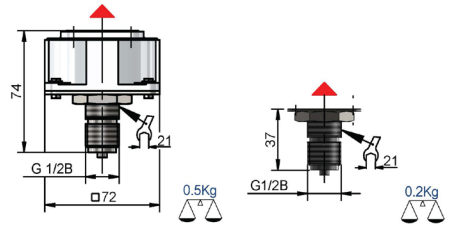

DPB

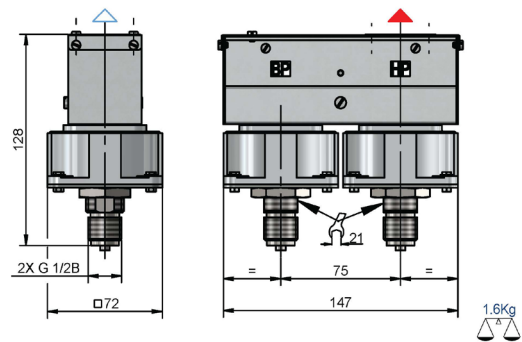

DPB/DMPB

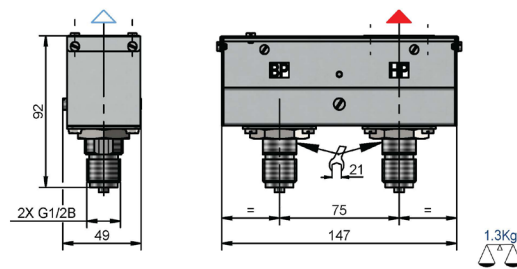

BOURDON TUBES

PL anti-corrosion version

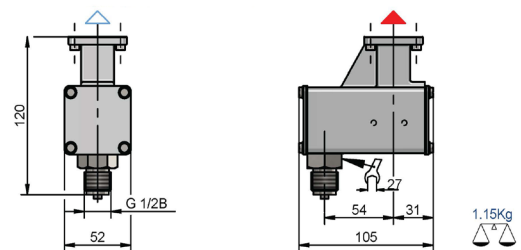

PL standard version

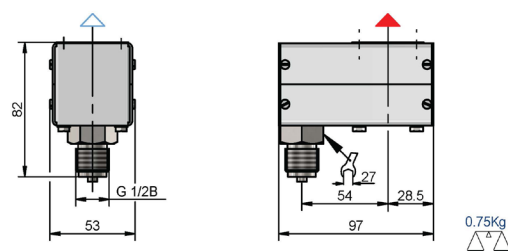



Industrial Range

P Series Pressure switches and temperature switches

■ CERTIFICATION FOR AREAS AT RISK OF EXPLOSION*

P series pressure switches and temperature switches comply with Directive 2014/34/EU and are suitable for installation in areas at risk of explosion. They are broken down into 4 construction and protection modes:

■ Intrinsic Safety

Installation areas*: 0/1/2 and 20/21/22

■ Increased safety or Explosion-proof safety

Installation areas*: 1/2 and 21/22

■ Constructional safety (for pneumatic equipment)

Installation areas*: 1/2 and 21/22

* The protection index of the instruments affects the installation areas, please refer to page 5 for more information.

■ PRESSURE EQUIPMENT DIRECTIVE - PED*

Series P pressure switches and temperature switches satisfy the requirements set forth in Annex I of PED 2014/68/EC. They are classified in Category IV as a safety accessory and can be incorporated in a safety loop to protect your processes.

■ TECHNICAL REGULATION (TR CU)*

TR CU is the certificate of conformity for the customs union of the Russian Federation, Belarus, Kazakhstan and Armenia. It indicates compliance with Russian laws and standards and authorises imports.

Note that, as the metrology certificate is intended for measurement tools, it is not applicable to pressure switches and temperature switches.

■ MARINE CERTIFICATION*

Bureau Veritas certification of pressure switches and temperature switches in accordance with the regulation of the classification of steel vessels on the high seas.

■ NATO ACCREDITATION CODE F3363

■ ELECTRICITE DE FRANCE ACCREDITATION NO. 82

■ NACE COMPLIANCE

316L stainless steel Bourdon tube and bellows-actuated pressure switches comply with NACE Standard MR0175/ISO 15156-3-2003.

■ RULES FOR DESIGN AND MANUFACTURE OF NUCLEAR ISLAND ELECTRICAL EQUIPMENT (RCCE-E 12-05)*

Qualifications K3 (functional tests, behaviour over time, resistance to earthquakes) and K3ad (functional tests, behaviour over time, resistance to earthquakes, irradiation) as per RCC-E §B4000

* Please consult us to define the models in question

