

- For continuous level measurement of liquids or bulk solids
- Wide spectrum of use, direct mounting into tanks, vessels, sumps or silos and hoppers
- Setting using a magnetic pen without the need for complete emptying of the tank
- Possibility of linear measurement even in non-conductive or variously shaped vessels
- Optical indication of function and status of level meter by two LEDs
- Wide selection of electrical connection: connector or cable glands
- Housing, electrodes and reference tubes made from stainless steel
- Variants with coated electrode for aggressive or electrically conductive media



The capacitive level meters DLM® are intended for continuous level measurement of liquid and bulk solids in tanks, vessels, sumps or silos, hoppers etc. They are comprised of a housing with electronic module and measuring electrodes. The electronic part converts the size of the capacity to the current signal (4 ... 20 mA) or voltage signal (0 ... 10 V). Level meters are made in several modifications of measuring electrodes (rod and rope). The electrodes can be covered by an insulating coating in case level measurement of adhesive, aggressive or electrically conductive media. Rod electrodes are also available in a version with reference (coaxial) tube for level measurement of liquids in tanks made from non-conductive material

Level meters are produced in the following performances: **N** – for non-explosive areas, **NT** – high temperature for non-explosive areas, **Xi** – Explosion proof – intrinsically safe for hazardous (explosive) areas and **XiM** – Explosion proof – intrinsically safe for use in mines with methane or flammable dust presence danger (see technical specifications). There are high temperature performance **NT**, **XiT**, **XiMT** available. DLM are offered in variants with various types of process connection (metric and pipe thread, pressure thread NPT).

### VARIANTS OF LEVEL METERS

- **DLM-35\_-20**     **Uncoated rod electrode** for level measurement of bulk-solids (cement, flour, sand, plastic granulate) and electrically non-conductive liquids (vegetable oil, diesel fuel, petrol). Maximum electrode length 2m.
- **DLM-35\_-21**     **Coated rod electrode (insulation FEP)** for level measurement of water and other electrically conductive liquids. Can also be used for polluted liquids in metal tanks, concrete sumps, etc. Maximum electrode length 2m.
- **DLM-35\_-22**     **Coated rod electrode (insulation PFA)** with enhanced resistance to permeation (diffusion) of vapours and gases. For level measurement of water and other electric conductive liquids in the food, pharmaceutical and chemical industries. In the short term can be used for high temperature applications (e.g. hot steam sanitation), or for volatile aggressive liquids, etc. Maximum electrode length 2m.
- **DLM-35\_-25**     like DLM-35\_-22 but higher pressure resistance at high temperature. Suitable for high temperature applications (hot steam) etc. Maximum electrode length 2m.
- **DLM-35\_-30**     **Uncoated rod electrode used** for level measurement of bulk-solids (cement, flour, sand, plastic granulate) and electrically non-conductive liquids (vegetable oil, diesel fuel, petrol). Maximum electrode length 3m.
- **DLM-35\_-31**     **Coated rod electrode (FEP)** for level measurement of water and other electrically conductive liquids. Can also be used for polluted liquids in metal tanks, concrete sumps, etc. Maximum electrode length 3m.

- **DLM-35\_-40** **Uncoated rod electrode with reference tube (coaxial electrode)** for accurate level measurement of unpolluted electrically non-conductive liquids (oils, diesel fuel, petrol). The measurement is not dependent on the tank shape and on the presence of objects in close proximity to the reference tube. Maximum electrode length 1 m.
- **DLM-35\_-41** **Coated rod electrode with reference tube (coaxial electrode)** for accurate level measurement of unpolluted electrically conductive liquids in plastic and glass tanks. The measurement is not dependent on the tank shape and on the presence of objects in close proximity to the reference tube. Maximum electrode length 1 m.
- **DLM-35\_-50** **Uncoated rope electrode with weight** for level measurement of bulk-solids (e.g. grains, sand, gravel, cement, etc.). Maximum electrode length 6 m.

## DIMENSIONAL DRAWINGS

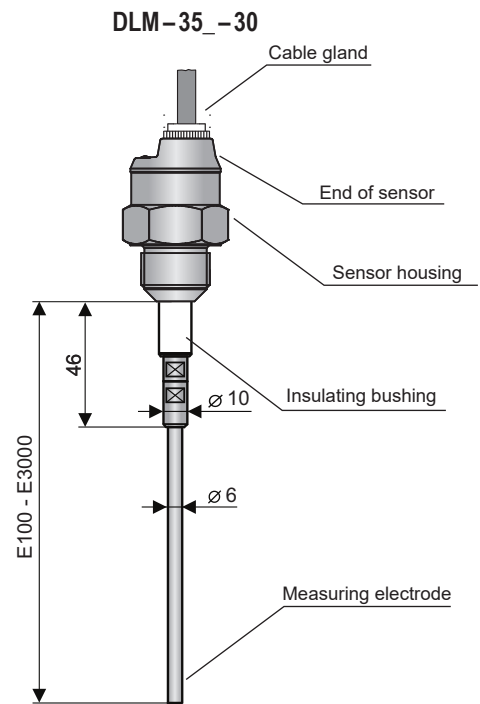
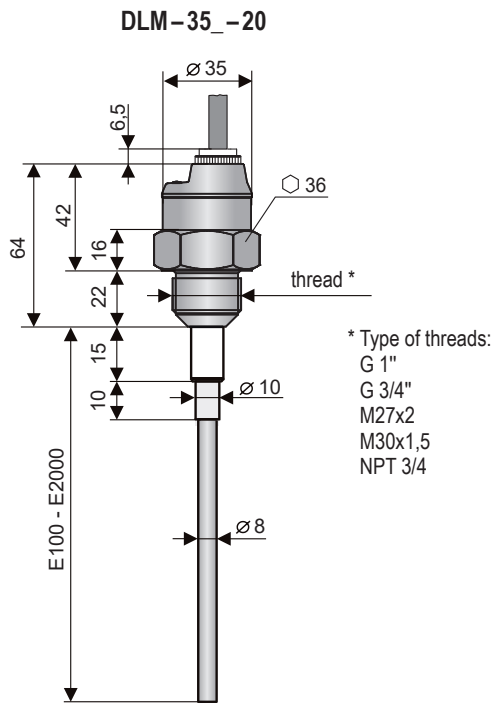

**DLM-35\_-21, 22, 25**

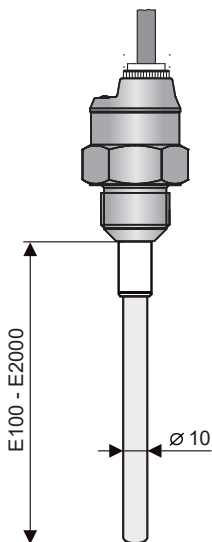

**DLM-35\_-31**

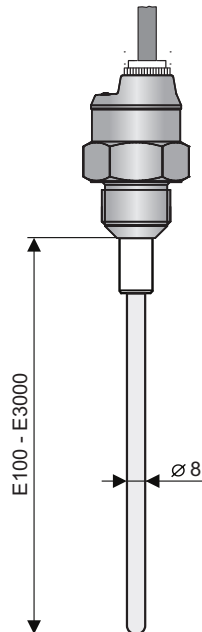

**DLM-35\_-40**

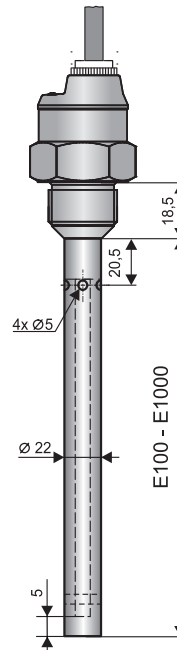

**DLM-35\_-41**

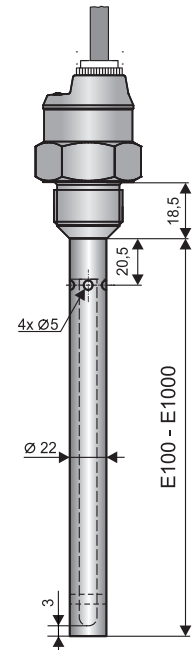

**DLM-35\_-50**

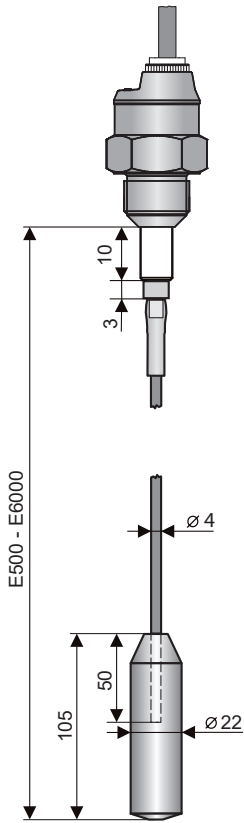

**High temperatures variants**

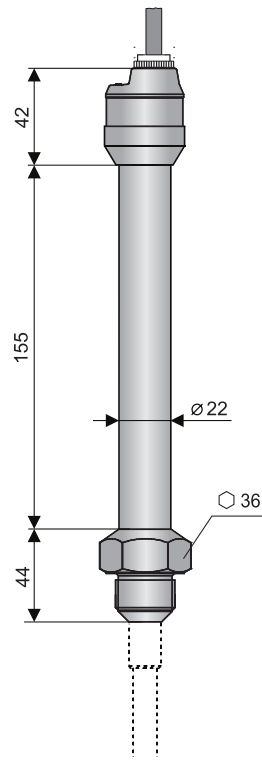

**Variant "A" with short stainless steel gland**

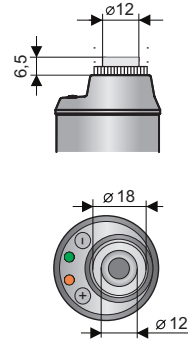

**Variant "C" with connector M12**

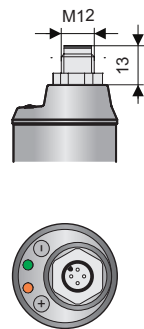

**Variant "B" with plastic threaded cable gland**

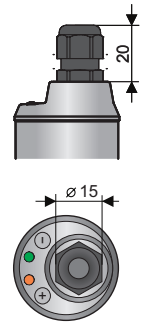

**Variant "D" with dustproof cable outlet**

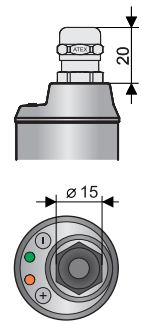

**Variant "V" with plastic cable gland with spiral relief - for case of increased mechanical wear on the cable.**

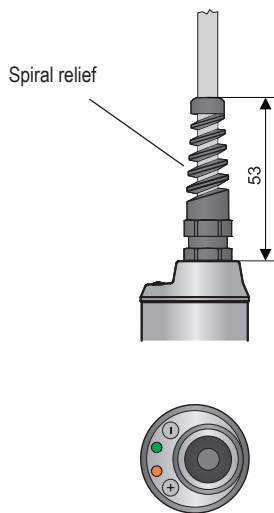

**Variant "H" with cable gland for protected hoses - for using in an outdoor area or in area with increased moisture.**

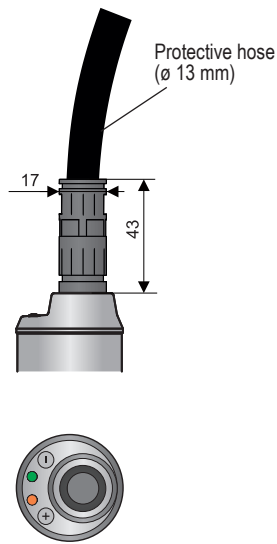

**Process connection Tri-clamp**

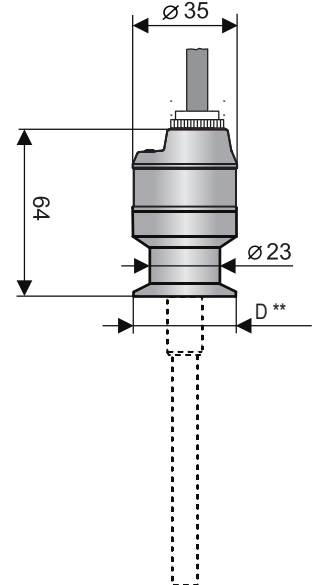

\*\* D: Tri-Clamp CI34 (ø 34 mm)  
Tri-Clamp CI50 (ø 50,5 mm)

All dimensions are in mm

## TECHNICAL SPECIFICATIONS

BASIC TECHNICAL DATA		
Supply voltage	DLM-35N(T)-__-__-I DLM-35N(T)-__-__-U	9 ... 34 V DC 12 ... 34 V DC
Current output Voltage output		4 ... 20 mA (2-wire) 0 ... 10 V (3-wire)
Power consumption	DLM-35__-__-__-I DLM-35__-__-__-U	3.75 ... 20.5 mA 5 mA (voltage output open circuit)
Non-linearity		max. 1%
Temperature error		max. 0.05% / K
Voltage error for current and voltage output		max. 0.3 µA/V and 0.1 mV/V
Leakage resistance (electrode - housing) / dielectric strength		1 MΩ / 200 V DC
Coupling capacity (housing - power) / dielectric strength		50 nF / 350 V AC
Coupling capacity (electrode - power) / dielectric strength		47 nF / 350 V AC
Ambient temperature range:		- 40 ... + 85 °C
Protection	type DLM-35__-__-C-__-__ type DLM-35__-__-A(B,V,H)-__-__	IP67 IP68
Maximum load resistance for current output (at U = 24 V)		$R_{max} = 700 \Omega$
Weight (excluding electrode and cable)	performance N performance NT	approx. 0.3 kg approx. 0.6 kg
Cable (version with cable glands)		PVC 2 x 0.75 mm <sup>2</sup> or 3 x 0.5 mm <sup>2</sup> (according to variant)

USE MATERIALS		
sensor part	variants	standard material *
<b>Wetted parts:</b>		
Housing	all types, expect Tri-Clamp Tri-Clamp	stainless steel W.Nr. 1.4301 (AISI 304) stainless steel W.Nr. 1.4404 (AISI 316L)
Rod electrode	all types expect DLM-35__-50	stainless steel W.Nr. 1.4404 (AISI 316L)
Rope electrode	DLM-35__-50	stainless steel W.Nr. 1.4401 (AISI 316)
Reference tube	DLM-35__-40, 41	stainless steel W.Nr. 1.4301 (AISI 304)
Insulating bushing	DLM-35__-20, 21, 22, 30, 31, 40, 41 DLM-35__-25, 50	PTFE PPS + GF40
Electrode coating	DLM-35__-21, 31, 41 DLM-35__-22, 25	FEP PFA
Weight	DLM-35__-50	stainless steel W.Nr. 1.4301 (AISI 304)
<b>Non-wetted parts:</b>		
Cable gland	DLM-35__-__-A DLM-35__-__-B DLM-35__-__-D DLM-35__-__-V DLM-35__-__-H	stainless steel W.Nr. 1.4571 (AISI 316 Ti) / NBR plastic PA / NBR nickel-plated brass / PA / rubber CR / NBR plastic PA / NBR plastic PA / NBR
Connector M12	DLM-35__-__-C	nickel-plated brass / PA

\* It is always necessary to verify the chemical compatibility of the material with the measured medium. You can also choose another type of material after agreement.

PROCESS CONNECTION		
type	size	marking
Pipe thread	G 1"	G 1
	G 3/4"	G3/4
Metric thread	M27x2	M27
	M30x1,5	M30
Taper pipe thread	NPT 3/4	NPT
Jointless connection (Tri-Clamp)	ø 34 mm	CI34
	ø 50,5 mm	CI50

## ELECTRICAL PARAMETERS (variant Xi, XiT, XiM, XiMT)

Power supply voltage	9 ... 30 V DC
Limit values	Ui= 30 VDC; li= 132 mA; Pi=0,99 W; Ci=35 nF; Li= 10 µH
Reference value LC for the parameters of the used cable	typic C < 150 pF/m typic L < 0,8 µH /m

## WORKING AREAS AND AREA CLASSIFICATION (EN 60079-0, EN 60079-10-1(2))

DLM-35N	Basic performance for non-explosive atmospheres.
DLM-35NT	High-temperature basic performance for non-explosive atmospheres.
DLM-35Xi	Intrinsically safe explosion-proof performance for use in hazardous areas (explosive gas atmospheres or explosive atmospheres with dust) Ⓜ II 1 G Ex ia IIB T4 Ga; Ⓜ II 1 D Ex ia IIIC T120°C Da with intrinsically safe supply units, whole sensor zone 0 and 20.
DLM-35XiT	Intrinsically safe high-temperature explosion-proof performance for use in hazardous areas (explosive gas atmospheres or explosive atmospheres with dust) Ⓜ II 1/2 G Ex ia IIB T4 Ga/Gb; Ⓜ II 1/2 D Ex ia IIIC T120°C Da/Db with intrinsically safe supply units, electrode part zone 0 and 20, head zone 1 and 21.
DLM-35XiM	Intrinsically safe explosion-proof performance for use in mines with the occurrence of methane or coal dust Ⓜ I M1 Ex ia I Ma with intrinsically safe supply units.
DLM-35XiMT	Intrinsically safe high-temperature explosion-proof performance for use in mines with the occurrence of methane or coal dust Ⓜ I M1 Ex ia I Ma with intrinsically safe supply units.

## TEMPERATURE RESISTIVITY (variant N, NT, Xi, XiM, XiT, XiMT)

variant	temperature tm	temperature tp	temperature ta
DLM-35N-20, 30	-40°C ... +300°C	-40°C ... +85°C	-40°C ... +85°C
DLM-35N-21, 22, 31, 40, 41	-40°C ... +200°C	-40°C ... +85°C	-40°C ... +85°C
DLM-35N-25	-40°C ... +200°C	-40°C ... +85°C	-40°C ... +85°C
DLM-35N-50	-40°C ... +250°C	-40°C ... +85°C	-40°C ... +85°C
DLM-35NT-20, 30,	-40°C ... +300°C	-40°C ... +200°C	-40°C ... +85°C
DLM-35NT-21, 22, 31, 40, 41	-40°C ... +200°C	-40°C ... +200°C	-40°C ... +85°C
DLM-35NT-25	-40°C ... +200°C	-40°C ... +200°C	-40°C ... +85°C
DLM-35NT-50	-40°C ... +250°C	-40°C ... +200°C	-40°C ... +85°C
DLM-35Xi, XiM-20, 30	-40°C ... +300°C	-40°C ... +75°C	-40°C ... +75°C
DLM-35Xi, XiM-21, 22, 31, 40, 41	-40°C ... +200°C	-40°C ... +75°C	-40°C ... +75°C
DLM-35Xi, XiM-25	-40°C ... +200°C	-40°C ... +75°C	-40°C ... +75°C
DLM-35Xi, XiM-50	-40°C ... +250°C	-40°C ... +75°C	-40°C ... +75°C
DLM-35XiT, XiMT-20, 30	-40°C ... +300°C	-40°C ... +200°C	-40°C ... +75°C
DLM-35XiT, XiMT-21, 22, 31, 40, 41	-40°C ... +200°C	-40°C ... +200°C	-40°C ... +75°C
DLM-35XiT, XiMT-25	-40°C ... +200°C	-40°C ... +200°C	-40°C ... +75°C
DLM-35XiT, XiMT-50	-40°C ... +250°C	-40°C ... +200°C	-40°C ... +75°C
DLM-35XiM (XiMT) - mine application	Max. 150°C on any surface where the coal-dust can form layers		

Note: For the correct operation of the level sensor, none of the here provided temperature ranges may be exceeded (tp, tm or ta). The here-mentioned temperatures are visually explain in Fig.

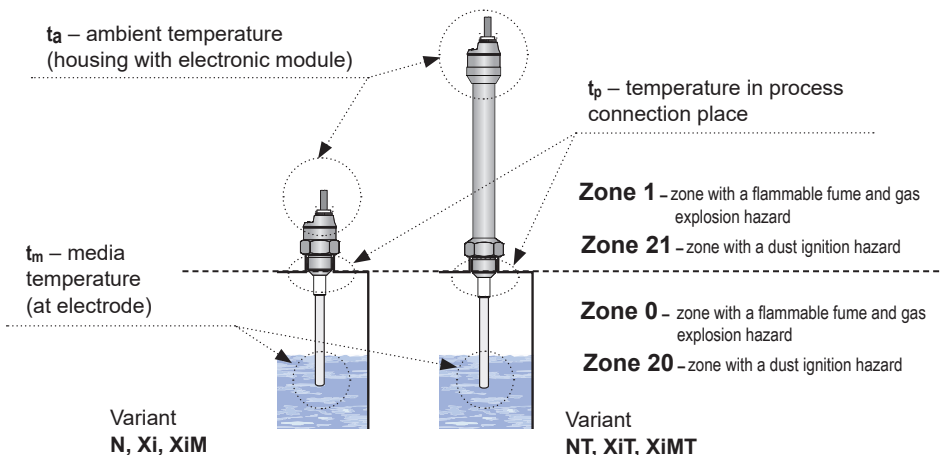

Illustration of areas for temperature measurement and explosive zones

## PRESSURE RESISTIVITY (variant N, NT, Xi, XiM, XiT, XiMT)

variant	max. operating pressure for temperature $t_p$				
	Up to 30°C	Up to 85°C	dUp to 120°C	Up to 150°C	Up to 200°C
DLM-35N-20, 30	5 MPa (50 bar)	2,5 MPa (25 bar)	–	–	–
DLM-35N-21, 22, 31, 40, 41	5 MPa (50 bar)	2,0 MPa (20 bar)	–	–	–
DLM-35N-25	2,0 MPa (20 bar)	2,0 MPa (20 bar)	–	–	–
DLM-35N-50	0,1 MPa (1 bar)	0,1 MPa (1 bar)	–	–	–
DLM-35NT-20, 30,	5 MPa (50 bar)	2,5 MPa (25 bar)	1,5 MPa (15 bar)	1 MPa (10 bar)	0,5 MPa (5 bar)
DLM-35NT-21, 22, 31, 40, 41	5 MPa (50 bar)	2,0 MPa (20 bar)	1,5 MPa (15 bar)	1 MPa (10 bar)	0,1 MPa (1 bar)
DLM-35NT-25	2,0 MPa (20 bar)	2,0 MPa (20 bar)	2,0 MPa (20 bar)	2,0 MPa (20 bar)	2,0 MPa (20 bar)
DLM-35NT-50	0,1 MPa (1 bar)	0,1 MPa (1 bar)	0,1 MPa (1 bar)	0,1 MPa (1 bar)	0,1 MPa (1 bar)
DLM-35Xi, XiM-20, 30	5 MPa (50 bar)	2,5 MPa (25 bar)	–	–	–
DLM-35Xi, XiM-21, 22, 31, 40, 41	5 MPa (50 bar)	2,0 MPa (20 bar)	–	–	–
DLM-35Xi, XiM-25	2,0 MPa (20 bar)	2,0 MPa (20 bar)	–	–	–
DLM-35Xi, XiM-50	0,1 MPa (1 bar)	0,1 MPa (1 bar)	–	–	–
DLM-35XiT, XiMT-20, 30	5 MPa (50 bar)	2,5 MPa (25 bar)	1,5 MPa (15 bar)	1 MPa (10 bar)	0,5 MPa (5 bar)
DLM-35XiT, XiMT-21, 22, 31, 40, 41	5 MPa (50 bar)	2,0 MPa (20 bar)	1,5 MPa (15 bar)	1 MPa (10 bar)	0,1 MPa (1 bar)
DLM-35XiT, XiMT-25	2,0 MPa (20 bar)	2,0 MPa (20 bar)	2,0 MPa (20 bar)	2,0 MPa (20 bar)	2,0 MPa (20 bar)
DLM-35XiT, XiMT-50	0,1 MPa (1 bar)	0,1 MPa (1 bar)	0,1 MPa (1 bar)	0,1 MPa (1 bar)	0,1 MPa (1 bar)

## INSTALLATION INSTRUCTIONS

- Level meters with coated electrode have protection cover at the end of electrode, which is necessary take down before mounting.
- Level meters mount in vertical position to upper lid of tank or reservoir by welding flange, fixing nut or Clamp flange.
- For mounting level meter to the metal tank or hopper, it is not necessary to ground the housing again.
- In case of installation in concrete sumps or silos, it is appropriate to install the level meter onto a metallic auxiliary construction (console, lid, etc.) and then connect with metal constantly submerged object, eventually with steel armouring.
- For level measurement of material in plastic and glass vessels by level meter without reference tube is necessary to connect grounding screw at housing with auxiliary electrode which is fixed in an appropriate manner to the outer casing of vessels (or at the inner wall). Material of auxiliary electrode must be selected with consideration for the working environment and properties of measured material.

### Variants with rod electrode

DLM-35\_-20, 21, 22, 25, 30, 31

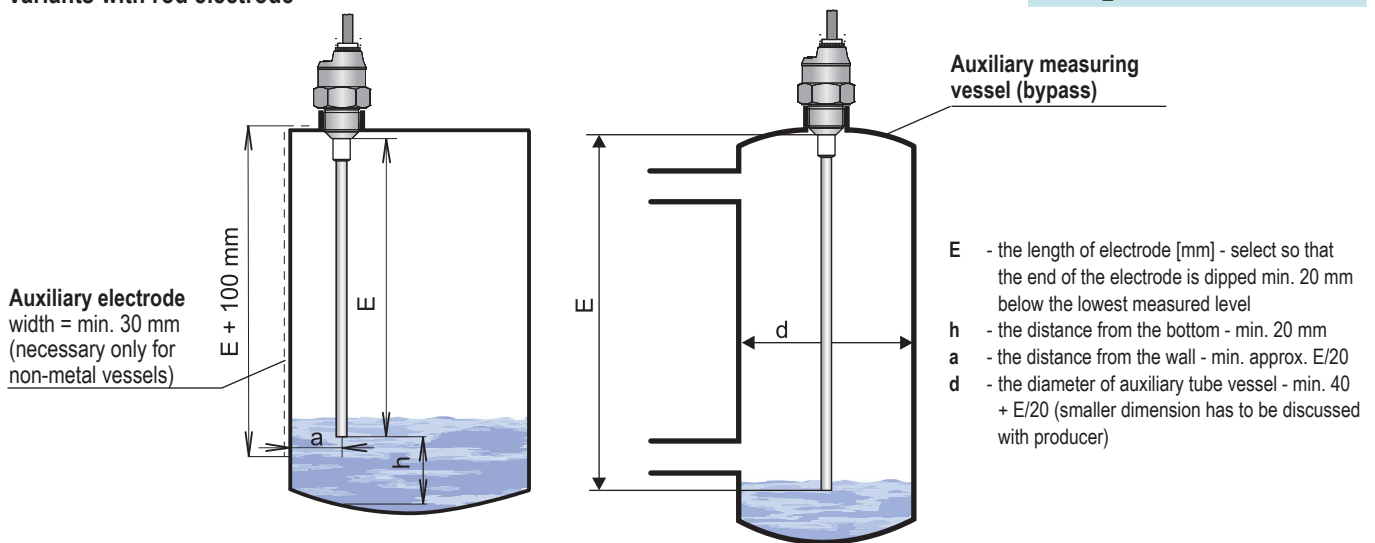

Installation of level meters with rod electrode

## Variants with reference tube

DLM-35\_-40, 41

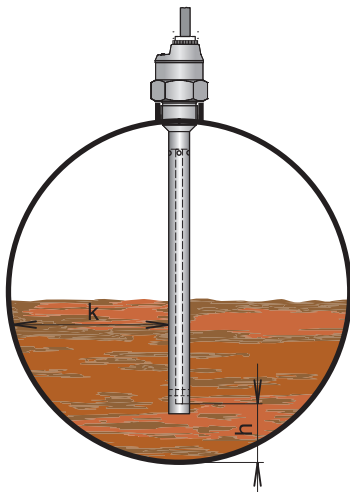

Installation of level meter with reference tube

- h** - distance from bottom - min. 20 mm with regard to possibility of the presence of heavier fractions (water) in petroleum products
- k** - the distance from the wall - optional

## Variants with rope electrode

DLM-35\_-50

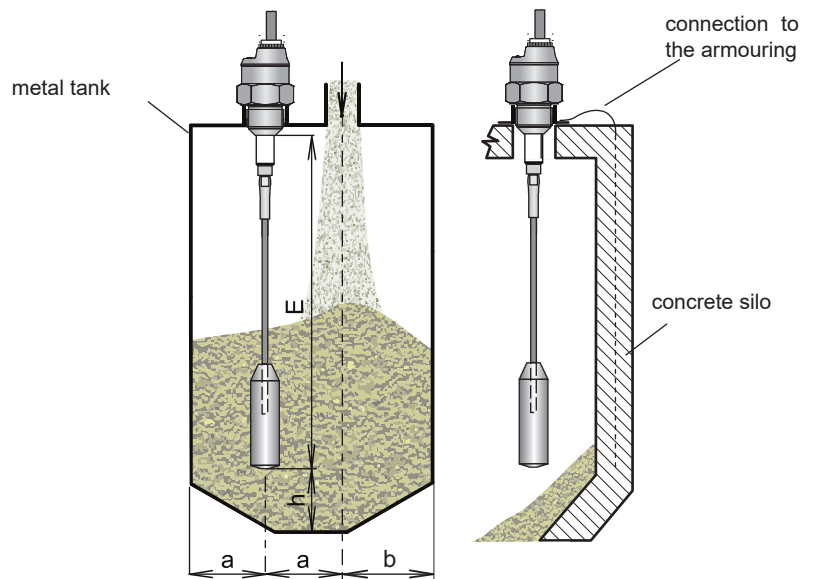

Installation of level meter with rope electrode

- E** - electrode length [mm] - select so that the end of the electrode would be at least 20 mm under the lowest measured level
- h** - distance from bottom - min. 100 mm
- a** - distance from wall - min.  $E/20$ , otherwise select the largest (as far as possible from the wall), towards the middle between the wall and vertical drain

## ELECTRICAL CONNECTION

The positive pole of the supply voltage (+U) is connected to the brown wire BN or pin connector no.1, the negative pole (0V) is connected to the blue wire BU or pin connector no. 3 and output voltage (U<sub>out</sub>) to the black wire BK or pin connector no. 4.

Wiring diagrams are provided in the figures.

Note: In case of strong ambient electromagnetic interference, paralleling of conductors with power distribution, or for the distribution to distance over 30 m, we recommend using shielded cable.

Level meters DLM-35 with type of cable outlet A, B, V or H are connected to assessing units permanently connected by PVC cable.

Level meters DLM-35 with connection method type C are connected to assessing units by means of a connector socket with compression cable (length 2 or 5 m), or by means of a connector socket without cable (see accessories), the connector is not part of the sensor. In this case the cable is connected to the inside pins of the socket according to figure 6. The recommended diameter of this cable is 4 to 6 mm (the recommended cross-sectional area is 0.25 to 0.5 mm<sup>2</sup>).

The length of the cable for the Xi, XiT, XiM, XiMT variations must be selected with respect to the maximum permitted parameters (usually inductance and capacity) of the outside intrinsically safe circuit of supply units IRU-420.

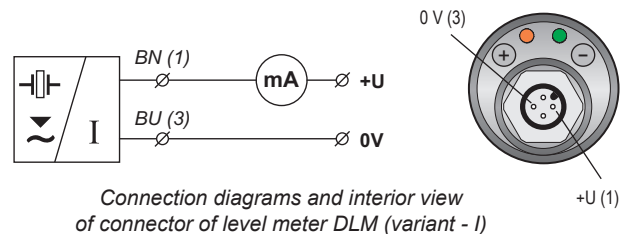

Connection diagrams and interior view of connector of level meter DLM (variant - I)

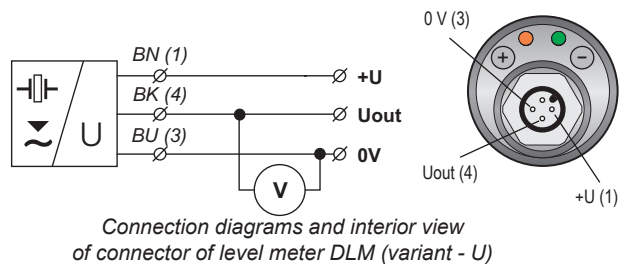

Connection diagrams and interior view of connector of level meter DLM (variant - U)

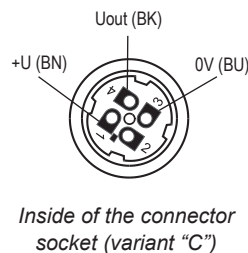

Inside of the connector socket (variant "C")

### Legend:

- (1...)- terminal numbers connector sockets
- BN** - brown
- BU** - blue
- BK** - black



Electrical connection can only be made when de-energized!

The source of the power voltage must comprise of a stabilised safe low power source with galvanic separation. In the event that a switch-mode power supply is used, it is essential that its construction effectively suppresses common mode interference on the secondary side. In the event that the switch-mode power supply is equipped with a PE safety terminal, it must be unconditionally grounded! Spark-safe devices type DLM-35Xi (XiT, XiM, XiMT) must be powered from a spark-safe power source meeting the above-mentioned requirements.



Due to the possible occurrence of an electrostatic charge on the non-conductive parts of the sensor, it is necessary to ground all sensors intended for use in environments with an explosion hazard DLM-35Xi (XiT, XiM, XiMT). This can be performed by grounding el. conductive tanks or el. conductive tank lids, and in the case of el. non-conductive tanks using and grounding an auxiliary plate electrode PDE-27.

In the event that the level meter is installed in an outdoor environment at a distance greater than 20 m from the outdoor switchboard, or from an enclosed building, it is necessary to supplement the electrical cable leading to the level meter with suitable overvoltage protection.

In the event of strong ambient electromagnetic interference, paralleling of conductors with power distribution, or for distribution to distances over 30 m, we recommend using a shielded cable and grounding the shielding on the side of the power source.

## SETTINGS

Settings of the measuring range are done by touching a magnetic pen to the pair of sensitive spot “-” and “+”. Sensitive spot “-” used for input to the setting mode for setting the limit 4 mA (0V) and decreasing the set current (voltage). Upon reaching the required current (voltage) waits for a permanently illuminated orange LED, and by applying the magnetic pen to the sensitive area “-”, confirmation is performed of the set value. Sensitive area “+” is used for input to the setting mode for setting the limit setting 20 mA (10V) and increasing the set current (voltage). Upon reaching the required current (voltage) it waits for a permanently illuminated orange LED, and by applying the magnetic pen to the sensitive area “+” confirmation is performed of the set value. The setting process is indicated by the orange LED “STATE”. The green LED indicator “RUN” indicates correct function of level measurement.

You can find more information in the instruction manual.

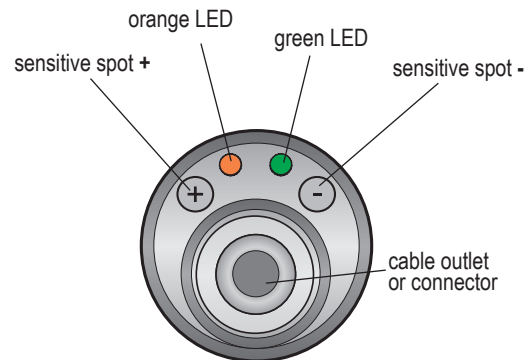

Top view of level meter

## FUNCTION AND STATUS INDICATION

LED indicator	colour	function
"RUN"	green	<p><b>Measuring function indicator</b></p> <p><b>flashing</b> – (repeats according to period of measuring approx. 0.5 s) – correct function of measuring the level</p> <p><b>dark</b> – incorrect installation or malfunction. LED is also not illuminated in limit setting mode.</p> <p><b>alternating flashing green and orange LED</b> – incorrectly set limits</p>
"STATE"	orange	<p><b>Settings indication</b></p> <p><b>slow flashing</b> – indication of setting the lower limit</p> <p><b>rapid flashing</b> – indication of setting the upper limit</p> <p><b>permanent shine</b> – the level meter is prepared to confirm the limit setting by means of mag. pen</p> <p><b>3x short flashes</b> – setting confirmation</p> <p><b>simultaneous shine of green and orange LED</b> – during touching the mag. pen, when the limit setting is confirmed</p>



## ORDER CODE

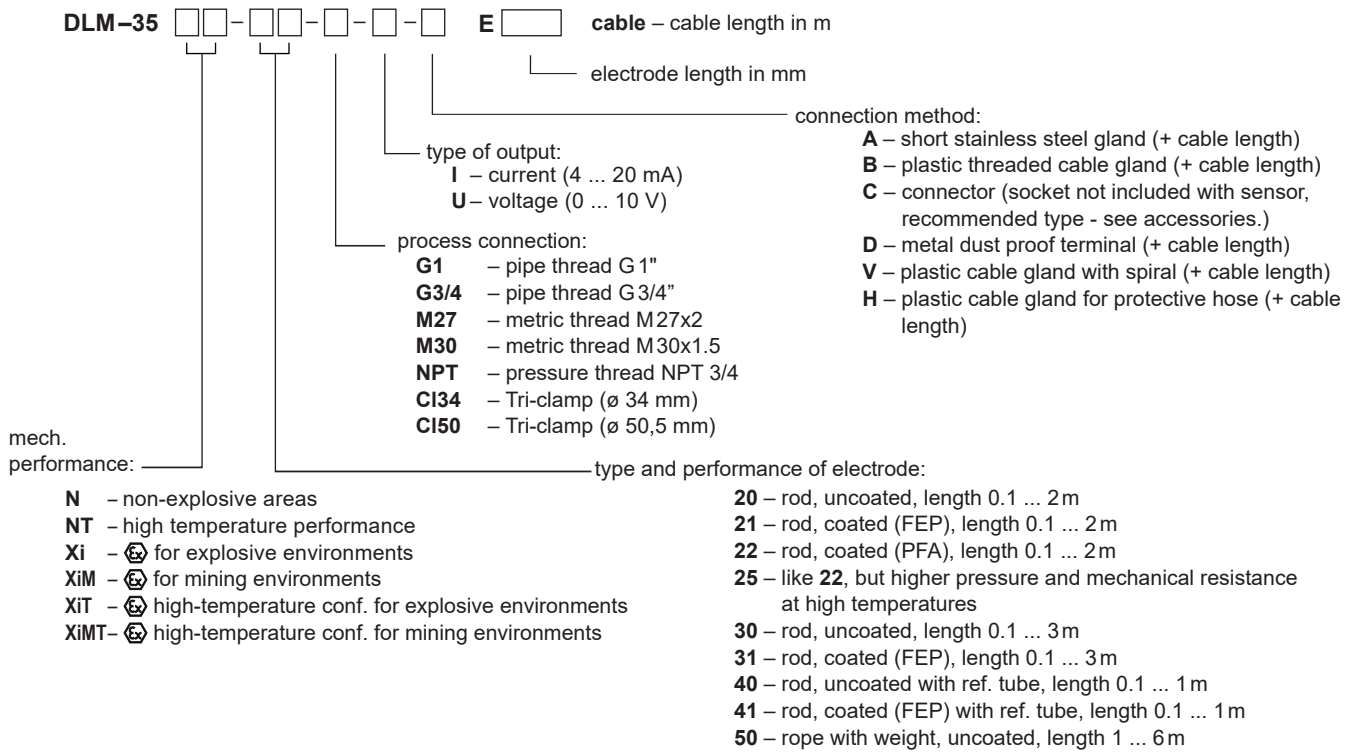

## CORRECT SPECIFICATION EXAMPLES

DLM-35N-20- M27-I-B E200 cable 5 m

(N) non-explosive areas; (20) uncoated cylindrical electrode; (M27) process connection by thread M27; (I) output current; (B) plastic threaded cable gland; (E200) electrode length 200 mm.

DLM-35N-21-G3/4-U-C E580

(N) non-explosive areas; (21) coated bar electrode (FEP); (G3/4) process connection by thread G3/4"; (U) output voltage; (C) connector; (E580) electrode length 580 mm.

DLM-35N-40-M30-I-H E900

(N) non-explosive areas; (40) uncoated rod electrode with reference tube; (M30) process connection by thread M30; (I) output current; (H) cable gland for protective hose; (E900) electrode length 900 mm.

DLM-35XiT-20- M27-I-B E200 cable 5 m

(XiT) high-temperature conf. for explosive environments; (20) uncoated cylindrical electrode; (M27) process connection by thread M27; (I) output current; (B) plastic threaded cable gland; (E200) electrode length 200 mm.

DLM-35N-22- CI50-U-A E200 cable 5 m

(N) non-explosive areas; (22) coated bar electrode (PFA); (CI50) process connection Tri-clamp (ø 50,5 mm); (U) output voltage; (A) short stainless steel gland; (E200) electrode length 200 mm.

## ACCESSORIES

**standard** - included in the level sensor price

- 1 pcs. magnetic pen MP-8
- 1 pcs. seal (asbestos free) \*

**optional** – for a surcharge (see catalogue sheet of accessories)

- cable (over the standard length 2m)
- connector socket (type ELWIKa or ELKA)
- normal steel welding flange or stainless steel welding flange
- protective hose (for type of cable outlet H)
- stainless steel fixing nut
- various types of seals (PTFE, Al, etc.)

\* Pressure resistance - see the table in the accessories datasheet in the "seals and gaskets".

## SAFETY, PROTECTIONS, COMPATIBILITY AND EXPLOSION PROOF

---

The level sensor is equipped with protection against electric shock on the electrode, reverse polarity, output current overload, short circuit and against current overload on output.

Protection against dangerous contact is provided by low safety voltage according to EN 33 2000- 4- 41. Electromagnetic compatibility is provided by conformity with standards EN 55022/B, EN 61326-1, EN 61000-4-2 to -8.

Explosion proof DLM–35Xi (XiT, XiM, XiMT) is provided by conformity with standards EN 60079-0, EN 60079-11, EN 60079-26.

Explosion proof DLM–35Xi (XiT, XiM, XiMT) is verified FTZÚ – AO 210 Ostrava – Radvanice: FTZÚ 16 ATEX 0140X.

A declaration of conformity was issued for this device in the wording of Act No. 90/2016 Coll., as amended. Supplied electrical equipment matches the requirements of valid European directives for safety and electromagnetic compatibility.

### **Special conditions for safe use of variant DLM–35Xi (XiT, XiM, XiMT)**

Level meters DLM-35Xi(XiT, XiM, XiMT) are intended for connection to approved spark-safe power supply unit circuits (of insulating transducers) with galvanic separation. In the event that devices without galvanic separation are used (Zener barriers), it is necessary to balance the potential between the sensor, resp. level meter and the barrier grounding location.

The limit output parameters of spark-safe units (insulating transducers) must correspond to the limit input parameters of the level meter. When assessing spark-free safety of circuits, it is necessary to also take into consideration the parameters of the connected cable (namely its induction and capacity).

The DLM-35Xi configuration may be located in zone 0 or zone 20. With the DLM-35XiT configuration it is only possible to locate the electrode part in zone 0 and in zone 20, and then the head with the electronics in zone 1 or zone 21.

Ambient temperature:  $T_{amb} = -40^{\circ}\text{C}$  to  $+75^{\circ}\text{C}$ .

The temperature of the measured material according to the variant configuration, see chapter "Technical parameters". The maximum temperature of the electrodes equals the temperature of the measured material.

Variant DLM–35XiMT it is necessary to observe that temperature of any surface of apparatus, when coal dust can from a layer, do not exceed  $150^{\circ}\text{C}$ .

## PACKINGS, SHIPPING AND STORAGE

---

The DLM-35 device is supplied packaged in a cardboard box that protects it against mechanical damage.

When handling and during transport, it is necessary to prevent impacts and falls.

The DLM-35 electrical device must be stored in dry enclosed areas with humidity up to 85%, free of aggressive vapours at temperatures between  $-10^{\circ}\text{C}$  and  $50^{\circ}\text{C}$ , and must be protected against the effects of weather.