

High pressure  
gear pumps  
**KP 1**  
Series 2

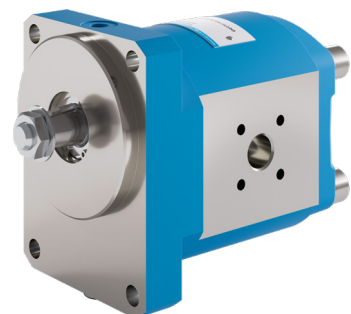

**KRACHT**®  
FLUID TECHNOLOGY AND SYSTEMS

## Content

---

Construction Function	4
Materials Characteristics	5
Calculation formulas for hydraulic pumps Technical Data	6
Explanation on flame resistant hydraulic fluids compliant Recommended values for efficiency dependent on the viscosity	7
Discharge flow and required input	8
Type key	9
Technical Drawings KP (Dimensions and weights)	10 – 12
Technical Data / Drawing – Pressure relief valve	13
Technical Data / Drawings – Couplings	14
Technical Data / Drawings – Connectors	15
Technical Data / Drawing – Bell Housing	16
Technical Data / Drawing – Motor-Pump Assemblies	17

## Description

### I Construction

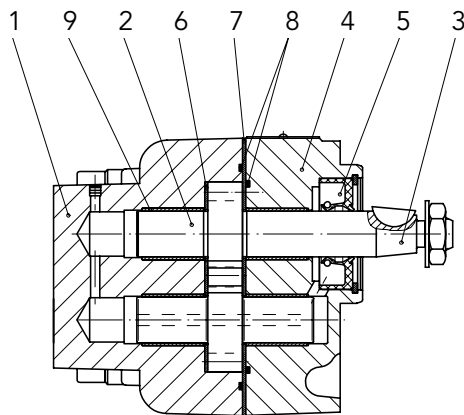

- 1 Housing
- 2 Gearing
- 3 Drive shaft end
- 4 Flange mounting cover
- 5 Rotary shaft lip-type seal
- 6 Sliding plate
- 7 Pressure plate
- 8 O-ring seal
- 9 Plain bearing bush

### I Function

KRACHT External gear pumps KP 1 series 2, due to their structure (design principle) and the materials employed, are ideal for use under the most extreme operating conditions. Important modular elements (see sectional drawing) are the housings and flanged covers - both made from grey cast iron or cast iron - can be highly loaded dynamically making them insensitive to pressure peaks and continuous vibrations. Large-surface-dimensioned, PTFE-Pb coated, bronze plain bearings on steel backs in the housing and flanged cover support the micro-finish ground bearing journals of the gear, which comprises the drive-shaft wheel and bolt wheel. To realise optimum running properties, the tooth flanks of the gear, which are manufactured out of casehardening steel, are ground.

This function of the active axial-play compensation, indispensable for high-pressure pump kidneys, is implemented under the pressure plate. It has hydraulically pressurised pressure-fields, guaranteeing compensation of the axial play at every operating pressure. The pressure plates are designed for viscosity-independent play-compensation. That ensures a high level of volumetric and mechanical efficiency at every operating point. NBR or FKM seals can be used to meet comprehensive application requirements caused by the temperature and/or media. These pumps are ideal for hydraulic oil, engine oil, HEES bio-oils and flame resistant fluids.

#### Note:

##### 1. External loads

Externally acting forces acting on the drive-shaft end influence the function of the bearing glands. Radial forces can possibly be absorbed depending on the size and direction of action. Axial forces are not permissible. To absorb the external forces, use pump versions with outboard bearings.

##### 2. Direction of rotation

Concerning the direction of rotation, - when looking at the drive shaft end - the following stipulation applies:

Shaft rotating clockwise:  
Feed direction from left to right.

Shaft rotating counter-clockwise:  
Feed direction from right to left.

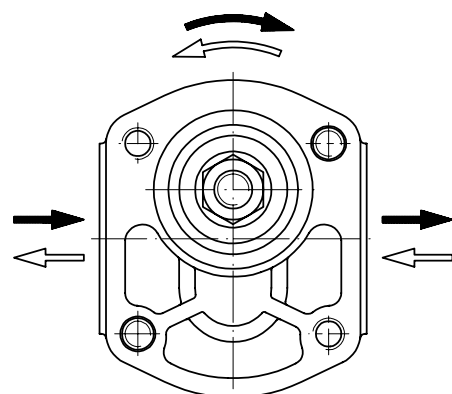

## Technical Data

### I Materials

Housing	EN-GJL-300
Flange mounting cover	EN-GJS-400-15
Bearing	Multi-compound plain bearing bushes
Shafts and gears	Casehardened and ground carburised steel according to DIN 17210
Seals	NBR $\vartheta \leq 90^\circ\text{C}$ FKM $\vartheta \leq 110^\circ\text{C}$ (P20-plain bearing) FKM $\vartheta \leq 150^\circ\text{C}$ (DU-plain bearing)

### I Characteristics

Mounting	flange or foot-type
Pipe connection	flange type threaded flange on request
Direction of rotation	clockwise <b>or</b> anticlockwise
Fitting position	optional (with containing water fluids see page 7)
Ambient temperature	$\vartheta_{u \text{ min}}$ = $-20^\circ\text{C}$ $\vartheta_{u \text{ max}}$ = $60^\circ\text{C}$
Working pressure Inlet port	$p_{e \text{ min}}$ = $-0.4 \text{ bar}$ (vacuum) $p_{e \text{ max}}$ = $2 \text{ bar}$  Flange mounting cover F $p_{e \text{ max}}$ = $25 \text{ bar}$ bei $n < 500 \text{ rpm}$ $p_{e \text{ max}}$ = $20 \text{ bar}$ bei $n < 1000 \text{ rpm}$ $p_{e \text{ max}}$ = $15 \text{ bar}$ bei $n < 1500 \text{ rpm}$
Working pressure Short time	$p_{e \text{ max}}$ = $5 \text{ bar}$
Working pressure Outlet port	$p_{e \text{ max}}$ = see technical data
Fluid temperature range	$\vartheta_{m \text{ max}}$ = $90^\circ\text{C}$ NBR $\vartheta_{m \text{ max}}$ = $110^\circ\text{C}$ FKM (P20-plain bearing) $\vartheta_{m \text{ max}}$ = $150^\circ\text{C}$ FKM (DU-plain bearing)
Viscosity	$v_{\text{min}}$ = $1.2 \text{ mm}^2/\text{s}$ $v_{\text{max}}$ = $600 \text{ mm}^2/\text{s}$
Recommended oil cleanliness	acc. to ISO 4406:1999 Code 21/19/16 acc. to NAS 1638 class 10
Discharge flow	see chart page 8
Input power	see chart page 8
Hydraulic fluids	Mineral oil acc. to DIN 51524/25 Engine oil acc. to DIN 51511 Bio oils of type „HEES“ (VDMA 24568) Flame resistant fluids (VDMA 24317) Diesel, heating oil EL and kerosene on request

## Technical Data

### I Calculation formulas for hydraulic pumps

#### Characteristic data, formula signs, units

1. Discharge flow / input flow	Q	l/min
2. Pump /motor displacement	V <sub>g</sub>	cm <sup>3</sup> /rev
3. Pressure	p	bar
4. Speed of rotation	n	rpm
5. Torque	M	Nm
6. Power	P	kW
7. Total efficiency	η <sub>tot</sub>	-
8. Volumetric efficiency	η <sub>vol</sub>	-
9. Hydr./mech. efficiency	η <sub>hm</sub>	-
10. Flow velocity	v	m/s
11. Pipe diameter	d	mm

Characteristic data for:			
		Volumetric flow	Discharge flow $Q = \frac{V_g \cdot n \cdot \eta_{vol}}{10^3} \left[ \frac{l}{min} \right]$
		Torque	Drive torque $M = \frac{p \cdot V_g}{20 \cdot \pi \cdot \eta_{hm}} \text{ [Nm]}$
Power	Input power $P = \frac{p \cdot Q}{600 \cdot \eta_{tot}} \text{ [kW]}$		

#### General

$$Q_{th} = V_g \cdot n, \eta_{tot} = \eta_{vol} \cdot \eta_{hm}$$

$$M = 9549 \cdot \frac{P}{n}, v = 21.22 \frac{Q}{d^2}$$

Max. switching frequency: 30 /min

Pressure specifications apply to  $v \geq 34 \text{ mm}^2/\text{s}$

### I Technical Data

Nominal Displacement	Geom. Displacement V <sub>g</sub> in cm <sup>3</sup> /rev	Max. pressure P <sub>max</sub> in bar	Rated pressure P <sub>N</sub> in bar	Continuous working pressure P <sub>D</sub> in bar	Max. working speed n <sub>max</sub> in rpm	Moment of inertia x 10 <sup>-6</sup> J in kg m <sup>2</sup>	Minimum speed at p = ... bar				
							... 100	... 120	... 150	... 180	... 200
							n in rpm				
3	3.2	250	220	200	4000	24.8	700	800	1000	1200	1200
4	4.7	250	220	200	4000	31.1	600	800	900	1000	1100
5.5	5.7	250	220	200	4000	35.7	500	700	900	1000	1100
8	8.3	220	200	180	4000	48.4	500	700	900	1000	1000
11	11.3	200	180	160	3500	61.2	500	700	800	900	-
16	16.6	200	180	160	3000	85.5	500	600	800	800	-
20	20.4	160	140	120	2500	104.2	500	600	800	-	-

## Technical Data

### I Explanation on flame resistant hydraulic fluids compliant with VDMA 24317

1. HFA Moisture content > 80 % (Oil in water emulsion)
2. HFB Moisture content > 40 % (Water in oil emulsion)
3. HFC Moisture content > 35 % (Aqueous polymer solutions)
4. HFDR Moisture content = 0 % (Anhydrous fluids based on phosphoric acid esters)

Max. pressure	Max. pressure	Speed	Speed	Temperature	Seal	Inlet to pump required
	$p_{max}$ in bar	$n_{min}$ in rpm	$n_{max}$ in rpm	$\vartheta$ in °C		
HFA	40	1400	1800	5 ... 55	NBR	yes
HFB	80	see technical data	1800	5 ... 60	NBR	yes
HFC	120	see technical data	1800	-20 ... 60	NBR	yes
HFDR	140	see technical data	1800	-20 ... 110	FKM	yes

Water glycol coolants (e.g. Glythermin from BASF) must not be used!

**Note:** With HFA, HFB and HFC (all aqueous fluids), keep in mind that all components that come into contact with air (parting line between the medium and the air in the tank or air bubbles in the components) will corrode. For that reason, tanks require a special coating and it is mandatory that the pumps be attached below the tank level outside and inside. Never allow the pumps to run dry. When installing in the tank, the pumps must always be completely immersed into the medium. Attention: in case of varying volumes, always pay attention to and monitor the lowest liquid level!

### I Recommended values for efficiency dependent on the viscosity in $n = 1450$ rpm

$V_{g\ nenn}$	$\nu$	Pressure	$\eta_{vol}$	$\eta_{hm}$
in $cm^3/rev$	in $mm^2/s$	in bar	in %	in %
4	34	220	75	75
4	4	80	75	75
4	1.2	40	69	75

$V_{g\ nenn}$	$\nu$	Pressure	$\eta_{vol}$	$\eta_{hm}$
in $cm^3/rev$	in $mm^2/s$	in bar	in %	in %
11	34	180	90	90
11	4	80	80	90
11	1.2	40	78	90

$V_{g\ nenn}$	$\nu$	Pressure	$\eta_{vol}$	$\eta_{hm}$
in $cm^3/rev$	in $mm^2/s$	in bar	in %	in %
20	34	140	89	90
20	4	80	85	90
20	1.2	40	82	90

## Discharge flow and required input

### Discharge flow at n = 1450 rpm

Nominal Size	Pressure in bar							Discharge flow Q in l/min at 34 mm <sup>2</sup> /s
	20	60	100	140	180	200	220	
3	4.5	4.3	4.0	3.8	3.5	3.4	3.3	
4	6.6	6.3	6.0	5.7	5.4	5.3	5.1	
5.5	8.0	7.8	7.5	7.2	6.9	6.8	6.6	
8	11.7	11.4	11.1	10.7	10.4	10.2	-	
11	15.9	15.7	15.4	15.1	14.7	-	-	
16	23.4	23.1	22.7	22.3	21.9	-	-	
20	28.7	28.0	27.2	26.3	25.5	-	-	

### Required input at n = 1450 rpm

Nominal Size	Pressure in bar							Required input P in kW
	20	60	100	140	180	200	220	
3	0.27	0.64	1.00	1.36	1.72	1.90	2.08	
4	0.35	0.87	1.39	1.91	2.43	2.69	2.95	
5.5	0.38	0.94	1.51	2.08	2.64	2.93	3.21	
8	0.51	1.34	2.17	2.99	3.82	4.24	-	
11	0.66	1.78	2.91	4.03	5.16	-	-	
16	0.93	2.60	4.27	5.93	7.60	-	-	
20	1.10	3.11	5.12	7.12	-	-	-	

### Discharge flow at n = 950 rpm

Nominal Size	Pressure in bar							Discharge flow Q in l/min at 34 mm <sup>2</sup> /s
	20	60	100	140	180	200	220	
3	2.8	2.6	2.4	2.2	-	-	-	
4	4.2	3.9	3.6	3.4	3.1	-	-	
5.5	5.1	4.8	4.6	4.3	4.0	-	-	
8	7.4	7.1	6.9	6.6	6.2	6.1	-	
11	10.1	9.9	9.6	9.4	9.1	-	-	
16	14.9	14.6	14.3	14.0	13.6	-	-	
20	18.2	17.6	16.9	16.1	-	-	-	

### Required input at n = 950 rpm

Nominal Size	Pressure in bar							Required input P in kW
	20	60	100	140	180	200	220	
3	0.19	0.42	0.65	0.88	-	-	-	
4	0.24	0.57	0.90	1.23	1.56	-	-	
5.5	0.26	0.63	1.00	1.38	1.75	-	-	
8	0.34	0.88	1.43	1.97	2.51	2.79	-	
11	0.44	1.17	1.91	2.64	3.38	-	-	
16	0.61	1.68	2.75	3.83	4.90	-	-	
20	0.73	2.05	3.37	4.69	-	-	-	

## Type key

### Example

KP	1/	3	F	1	0	A	K	0	0	2	K	L	1	/...
1	2	3	4	5	6	7	8	9	10	11	12	13	14	15

#### 1 Product code

#### 2 Size

1

#### 3 Nominal displacement

3 · 4 · 5.5 · 8 · 11 · 16 · 20

#### 4 Selection: flange mounting cover (LA = Hole spacing / Ø Z = Centering diameter)

F	bolt square flange, LA = 60/60; Ø Z = 50
G	bolt rectangular flange, LA = 72 /100; Ø Z = 80, only in connection with K-shafts (special number 446)

#### 5 Direction of rotation

1	right
2	left

#### 6 Outboard flanges or bearing resp.

0	without
L	Bearing series light
U	Mounting angel with bearing

#### 7 Housing side ports

A	Inlet port Ø 15 with LK 40 up to V <sub>g</sub> 5.5 Inlet port Ø 20 with LK 40 from V <sub>g</sub> 8 Outlet port Ø 15 with LK 35
---	--

#### 8 Shaft end / Shaft load capacity

K	Taper 1:5 / 150 Nm <sub>max</sub>
L	Taper 1:5 for outboard bearing and mounting angle
X	Involute Spline B 17 x 14, DIN 5482 / 70 Nm <sub>max</sub>

#### 9 2. shaft end

0	without
---	---------

#### 10 Endcovers (adapter pieces)

0	without
---	---------

#### 11 Design serial no.

2	(specified by KRACHT)
---	-----------------------

#### 12 Code for materials (Housing and bearing type)

K	plain bearings P20	Cast iron housing and sliding plates
D	plain bearings DU	

#### 13 Type of gearing

L	Driving und driven gears of case hardening steel tooth flanks grinded and honed
---	---

#### 14 Seals

1	NBR θ ≤ 90 °C
2	FKM θ ≤ 110 °C (2KL) FKM θ ≤ 150 °C (2DL)

#### 15 Code-No. for special construction

--	--

## Dimensions and weights

### I F-flange, tapered shaft end

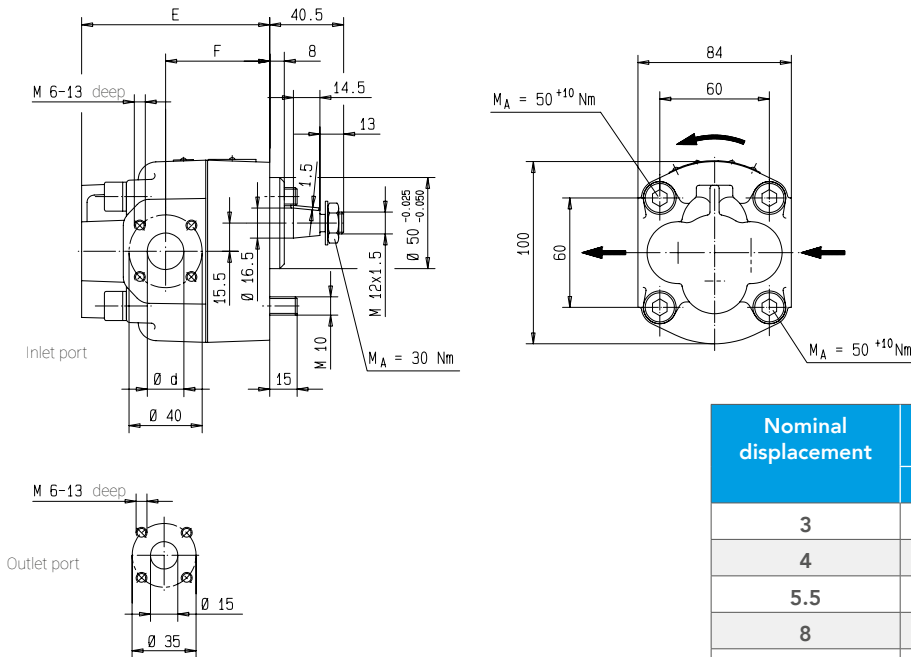

Shaft end: Taper 1:5  
Hex. lock nut M 12 x 1.5 EN ISO 8675  
Curved spring washer B12 DIN 137  
Woodruff key 3 x 6.5 DIN 6888  
The direction of rotation as represented is clockwise. In case of anticlockwise rotation the inlet and outlet ports are.

Nominal displacement	Dimensions			Weight in kg
	d	E	F	
3	Ø 15	103	54.8	4.4
4	Ø 15	103	57	4.4
5.5	Ø 15	103	57	4.2
8	Ø 20	103	57	4.3
11	Ø 20	103	57	4.4
16	Ø 20	103	57	4.4
20	Ø 20	105	63	4.6

### I F-flange, involute spline shaft end

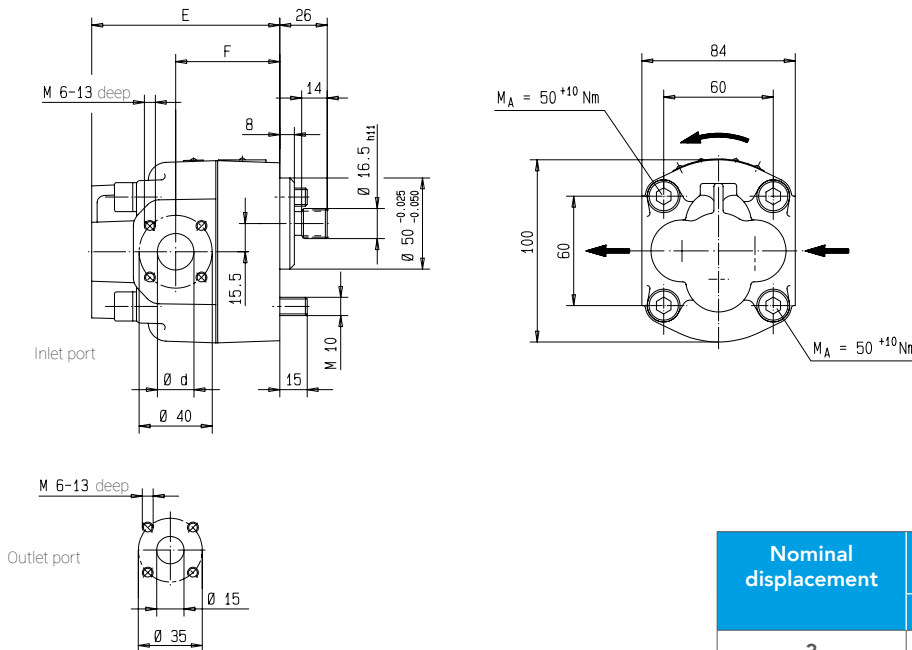

Gear shaft profile  
B17x14 DIN 5482  
gear-tooth thickness Sw = 3.206  
Off-set profiling = +0.6

Nominal displacement	Dimensions			Weight in kg
	d	E	F	
3	Ø 15	103	54.8	4.2
4	Ø 15	103	57	4.2
5.5	Ø 15	103	57	4.0
8	Ø 20	103	57	4.1
11	Ø 20	103	57	4.2
16	Ø 20	103	57	4.2
20	Ø 20	105	63	4.4

## Dimensions and weights

### I Outboard bearing type L, tapered shaft end

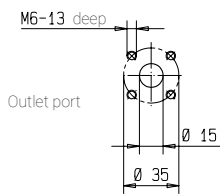
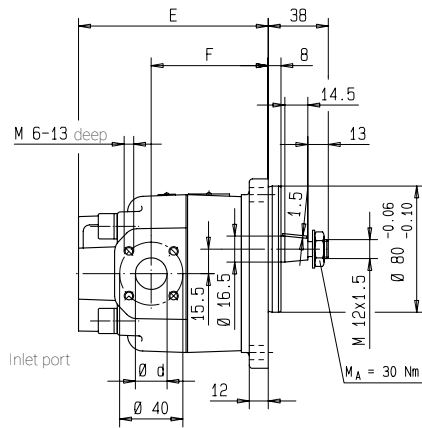

Permissible radial force N  
on centre shaft end  
(n = 1450 rpm) = 340 N

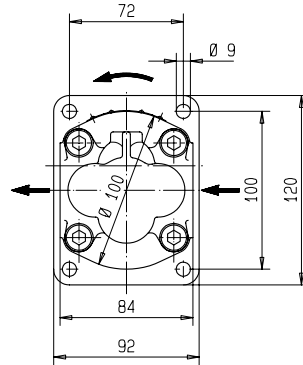

Shaft end: Taper 1:5  
Hex. lock nut M 12 x 1.5 EN ISO 8675  
Curved spring washer B12 DIN 137  
Wood druff key 3 x 6.5 DIN 6888

Nominal displacement	Dimensions			Weight in kg
	d	E	F	
3	Ø 15	120	71.8	5.4
4	Ø 15	120	74	5.4
5.5	Ø 15	120	74	5.2
8	Ø 20	120	74	5.3
11	Ø 20	120	74	5.4
16	Ø 20	120	74	5.4
20	Ø 20	122	80	5.6

### I Outboard without bearing type L, tapered shaft end (see type key flange mounting cover G)

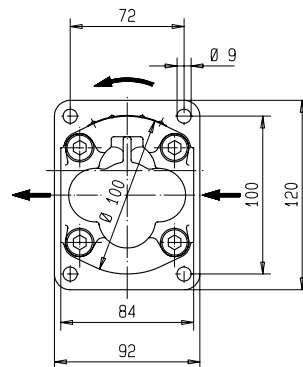
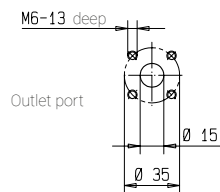
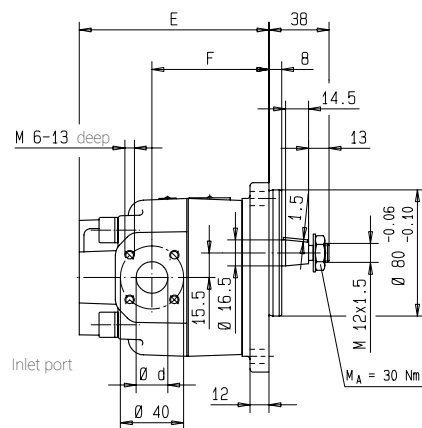

Shaft end: Taper 1:5  
Hex. lock nut M 12 x 1.5 EN ISO 8675  
Curved spring washer B12 DIN 137  
Wood druff key 3 x 6.5 DIN 6888

Nominal displacement	Dimensions			Weight in kg
	d	E	F	
3	Ø 15	120	71.8	5.3
4	Ø 15	120	74	5.3
5.5	Ø 15	120	74	5.1
8	Ø 20	120	74	5.2
11	Ø 20	120	74	5.3
16	Ø 20	120	74	5.2
20	Ø 20	122	80	5.5

Dimensions in mm

## Technical Data

### I Mounting angle, outboard bearing, tapered shaft end

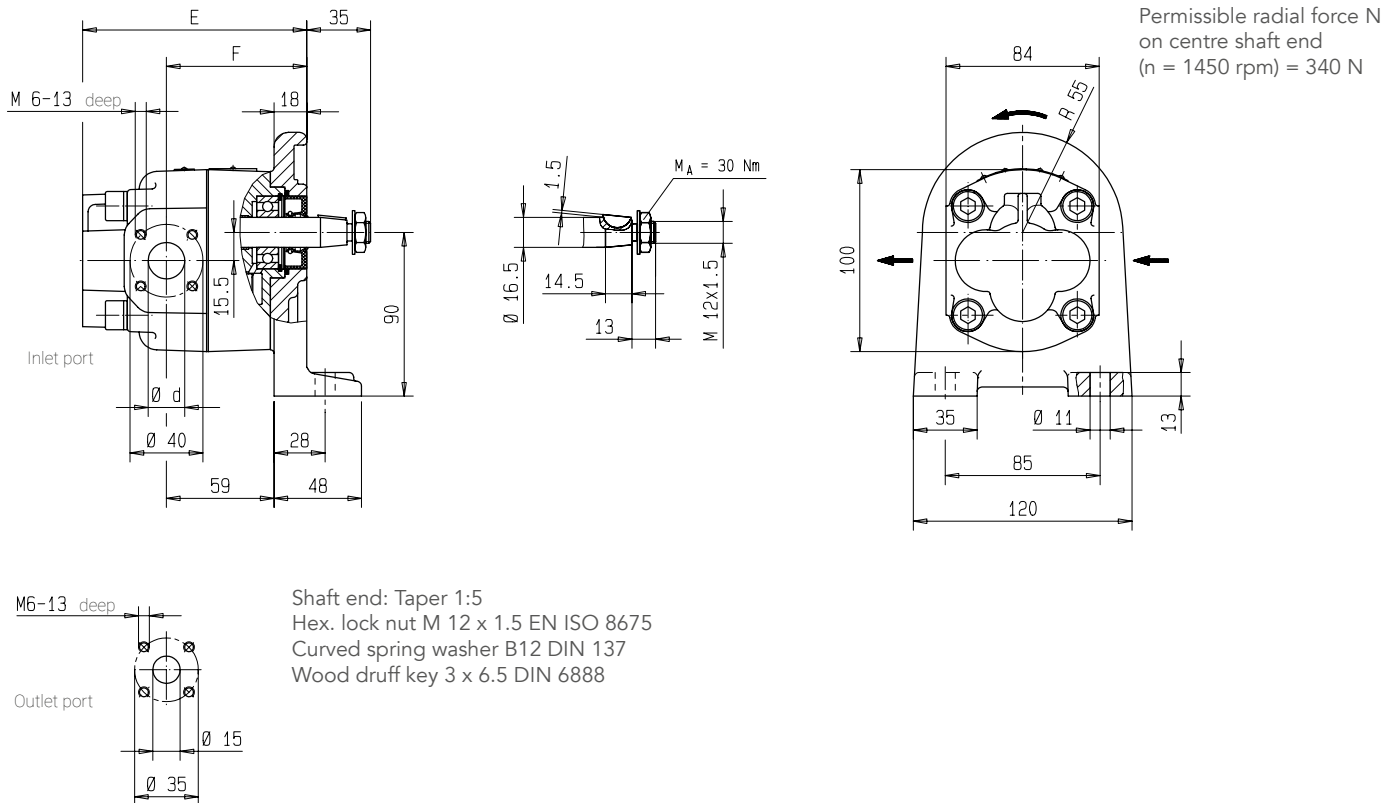

Nominal displacement	Dimensions			Weight in kg
	d	E	F	
3	Ø 15	123	74	6.0
4	Ø 15	123	77	6.0
5.5	Ø 15	123	77	5.8
8	Ø 20	123	77	5.9
11	Ø 20	123	77	6.0
16	Ø 20	123	77	6.0
20	Ø 20	125	83	6.2

## Technical Data

### I Pressure relief valve

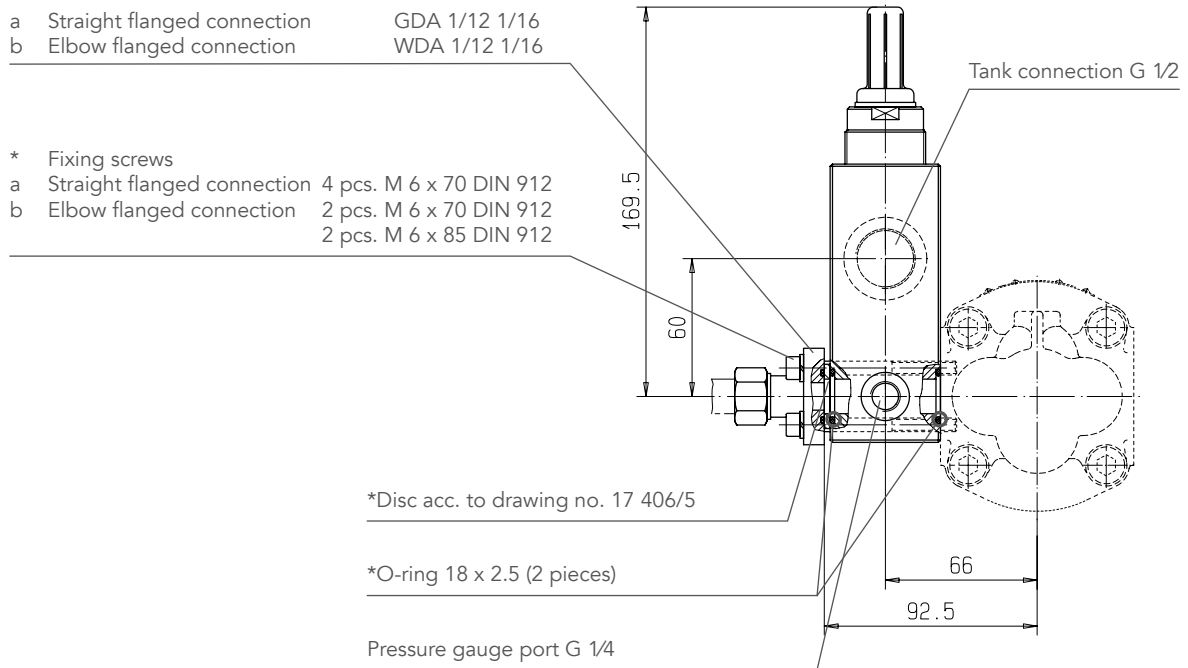

\* Extent of KRACHT delivery

Ordering code	Set pressure	Set pressure	Discharge flow	Discharge flow
	$P_{v1}$ in bar	$P_{v1}$ in bar	$Q_{1max}$ in l/min	$Q_{2max}$ in l/min
DBD 10 D 1 A 300	10	280	15	75
DBD 10 D 1 A 200	10	200	15	70
DBD 10 D 1 A 150	10	150	10	55
DBD 10 D 1 A 85	10	85	10	45
DBD 10 D 1 A 40	10	40	10	30
DBD 10 D 1 A 16	5	16	9	20

## Technical Data

### I Couplings

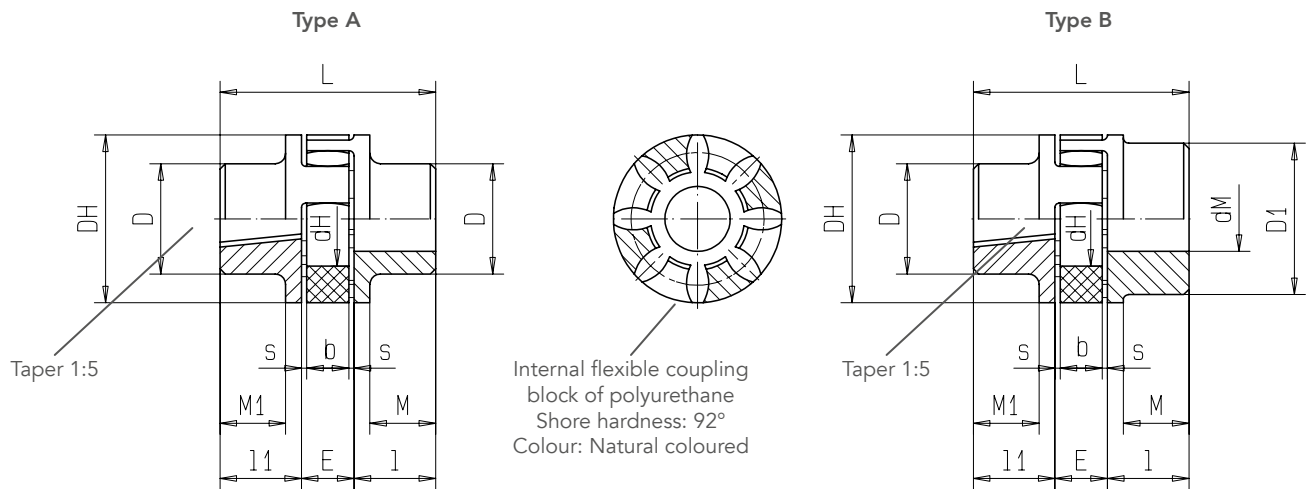

### Ordering code

<b>RA 24</b>	-	<b>K 18/17</b>	-	<b>Z 30/24</b>
Coupling Size		Length of the coupling hub and the hub bore pump sided		Length of the coupling hub and the hub bore motor sided straight hub bore

	Coupling Size	Weight in kg	Dimensions													Ordering code
			l	l <sub>1</sub>	E	s	b	L	M	M <sub>1</sub>	D <sub>H</sub>	D	D <sub>1</sub>	d <sub>h</sub>	d <sub>M</sub>	
Type A	24	1.2	50	18.5	18	2	14	86	-	8.0	55	48	-	27	14	RS 24-K18/17-Z 50/14
	24	0.3	30	30.0	18	2	14	78	24	24.0	56	40	-	27	19	RA 24-K30/17-Z 30/19
	24	0.2	30	18.5	18	2	14	66	24	12.5	56	40	-	27	24	RA 24-K18/17-Z 30/24
	38	2.6	70	18.5	24	3	18	112	62	10.5	80	78	-	38	38	RG 38-K18/17-Z 70/38
Type B	24/28	0.3	30	18.5	18	2	14	66	-	12.5	56	40	56	27	28	RA 24/28-Z 18/17-Z 30/28

Working temperatur: -40 °C to +90 °C (short time temperature peaks up to + 120 °C are permissible).  
Weights as well as moments of inertia relate to the max. bore dia. after final machining  
– but without key-way Bore finish acc. to ISO-fit class H7; key-ways acc. to DIN 6885 / part 1.

**RA:** Hub material Al  
**RG:** Hub material GG  
**RS:** Hub material Stahl

## Technical Data

### I Straight Flanged Connector

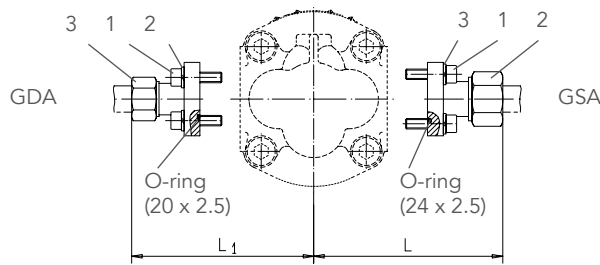

- 1 Hex. socket head cap screw (DIN 912 – 8.8)
- 2 Single coil spring lock washer (A6 DIN 127)
- 3 Covering nut with cutting ring (SW)

Extend of Kracht delivery: Hex. socket head cap screw acc. to DIN 912 as well as single coil spring lock washers and O-rings.

Inlet port Pipe externa dia. in mm	Ordering code	Discharge flow Q at 34 mm <sup>2</sup> /s in l/min	Dimensions		Cap screws	Weight in kg
			L	SW		
22	<b>GSA 1/22</b>	45	86	36	4 x M 6 x 22	0.23
18	<b>GSA 1/18</b>	30	86	32	4 x M 6 x 22	0.22
15	<b>GSA 1/15</b>	12	85	27	4 x M 6 x 22	0.19

Outlet port Pipe externa dia. in mm	Ordering code	Rated pressure PN in bar	Dimensions		Cap screws	Weight in kg
			L1	SW		
16	<b>GDA 1/16</b>	315	82	30	4 x M 6 x 22	0.18
15	<b>GDA 1/15</b>	250	81	27	4 x M 6 x 22	0.17
12	<b>GDA 1/12</b>	315	81	22	4 x M 6 x 22	0.16

### I Elbow Flanged Connector

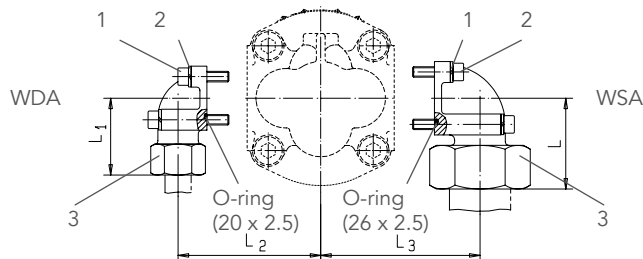

- 1 Hex. socket head cap screw (DIN 912 – 8.8)
- 2 Single coil spring lock washer (A6 DIN 127)
- 3 Covering nut with cutting ring (SW)

Extend of Kracht delivery: Hex. socket head cap screw acc. to DIN 912 as well as single coil spring lock washers and O-rings.

Inlet port Pipe externa dia. in mm	Ordering code	Discharge flow Q at 34 mm <sup>2</sup> /s in l/min	Dimensions			Cap screws		Weight in kg
			L	L <sub>3</sub>	SW			
35	<b>WSA 1/35</b>	65	52	74	50	2 x M 6 x 60	2 x M 6 x 22	0.55
28	<b>WSA 1/28</b>	45	49	70	41	2 x M 6 x 50	2 x M 6 x 20	0.38
22	<b>WSA 1/22</b>	25	47	64.5	36	4 x M 6 x 22		0.27
18	<b>WSA 1/18</b>	18	47	64.5	32	4 x M 6 x 22		0.25
15	<b>WSA 1/15</b>	12	46	64.5	27	4 x M 6 x 22		0.23

Outlet port Pipe externa dia. in mm	Ordering code	Rated pressure P <sub>N</sub> in bar	Dimensions			Cap screws		Weight in kg
			L <sub>1</sub>	L <sub>2</sub>	SW			
20	<b>WDA 1/20</b>	315	56	67	36	2 x M 6 x 45	2 x M 6 x 22	0.40
16	<b>WDA 1/16</b>	315	48	62	30	2 x M 6 x 40	2 x M 6 x 22	0.28
15	<b>WDA 1/15</b>	250	46	58.5	27	2 x M 6 x 35	2 x M 6 x 22	0.22
12	<b>WDA 1/12</b>	315	47	58.5	22	2 x M 6 x 35	2 x M 6 x 22	0.20

Dimensions in mm

## Technical Data

### I Aluminium Bell Housing for KP 1/..F.-Type

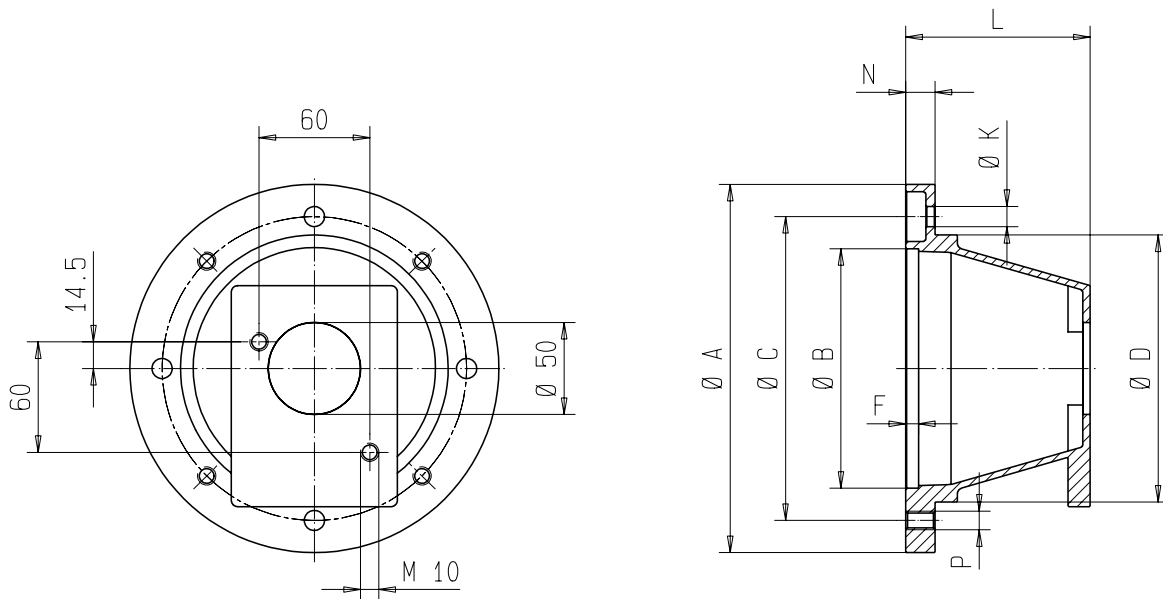

Type	Motorsize E-Motor	Dimensions									Adapter flange weight in kg	Coupling size
		A	B	C	D	F	K	L	N	P		
*Z1/200/100	80	200	130	165	145	7	11	100	16	M 10	0.9	RA 24- K30/17-Z30/19
*Z1/200/100	90	200	130	165	145	7	11	100	16	M 10	0.9	RA 24 - K18/17-Z30/24
Z1/250/110	100/112	250	180	215	190	7	14	110	19	M 12	1.2	RA 24/28 - K18/17-Z30/28
Z1/300/144	132	300	230	265	234	7	14	144	20	M12	1.9	RG 38 - K18/17-Z 70/38

Those adaptor flanges marked by \* are not suitable for installations into reservoirs because the pump flange dia. is larger than the centering dia. of the adaptor flange. Bell housing with vent hole or leakage oil-hole on request.

## Technical Data

### I Motor-Pump Assemblies KP 1/ . F.OA K00 2KL.

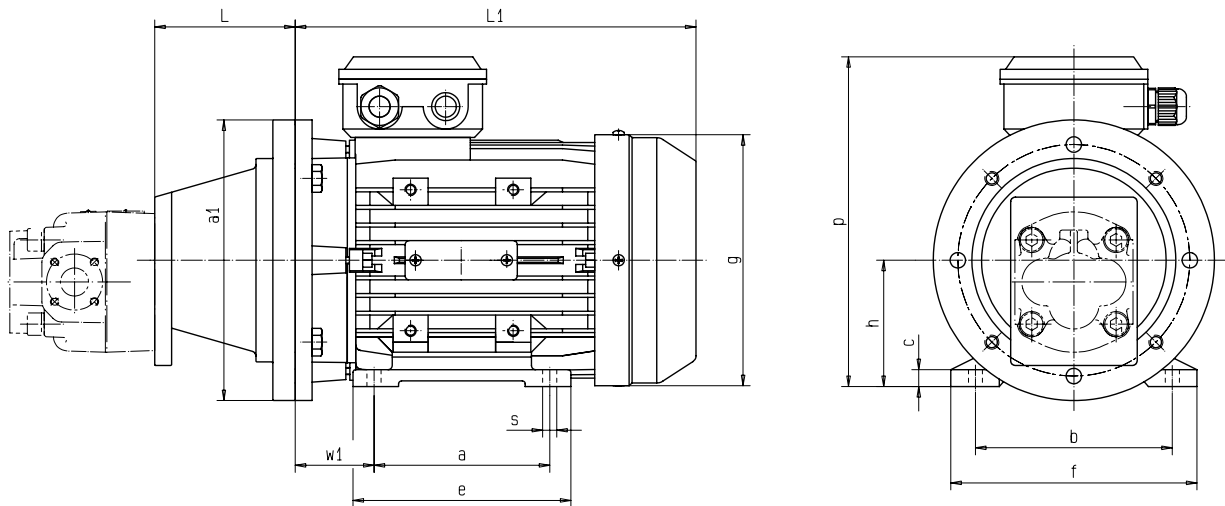

Nominal Size	Power	Operating	Leistung	Operating	Bellhousing	Coupling	Weight E-Motor		Weight Bell-housing
	Motor 6-pole		Motor 4-pole				6-pole	4-pole	
	in kW	in rpm	in kW	in rpm			in kg		
80	0.37	900	0.55	1370	Z1/200/100	RA 24-K30/17-Z30/19	8.1	8.1	0.9
80	0.55	900	0.75	1380			9.6	9.1	
90 S	0.75	920	1.10	1400	Z1/200/100	RA 24-K18/17-Z30/24	11.3	11.7	0.9
90 L	1.10	925	1.50	1400			14.4	14.4	
100	-	-	2.20	1420	Z1/250/110	RA 24/28-K18/17-Z30/28	-	19.2	1.2
100	1.50	945	3.00	1420			18.8	22.5	
112	2.20	955	4.00	1430			25.0	29.0	
132 S	3.00	960	5.50	1450	Z1/300/144	RG 38-K18/17-Z70/38	35.0	39.0	1.9
132 M	4.00	960	7.50	1450			47.6	48.6	

Nominal Size	Dimensions												
	L	a <sub>1</sub>	a	b	c	e	f	g	h	L <sub>1</sub>	p	s	w <sub>1</sub>
80	100	200	100	125	10	122	155	164	80	250	217	10	50
90 S	100	200	100	140	12	125	175	180	90	260	235	10	56
90 L	100	200	125	140	12	150	175	180	90	285	235	10	56
100	110	250	140	160	14	173	198	205	100	326	252	12	63
112	110	250	140	190	14	172	228	222	112	335	292	12	70
132 S	144	300	140	216	16	225	258	264	132	356	325	12	89
132 M	144	300	178	216	16	225	258	264	132	395	325	12	89

Motor frame sizes are based on ADDA. Other manufactures motors can be supplied on request as IM B 35.