

XL-VNSO

HIGH-DUTY CYCLE JOYSTICK CONTROLLERS

Construction:

The **TYPE XL-VNSO** 1, 2 and 3 Axis Joysticks are characterized by their compact design and super rugged construction for High-Duty cycle applications. XL-VNSO Joysticks are utilized for controlling electro-hydraulic proportional valves (EHPV) and AC/DC variable speed drives. Your specific control requirements can be accommodated by a variety of standard and custom engineered configurations.

Application: For use on cranes, bucket trucks, aerial work platforms and material handling equipment in the forestry, mining and construction industries.

Features:

- Versatile design
- Super heavy-duty construction
- Long-life, dual compression return springs each axis
- Nickel chromium gimbal yokes (properties similar to stainless steel)
- Hardened steel bearings and polished steel shaft guides
- Bronze gate handle stops
- Conformal coated electronics to resist moisture
- Type V7 11A form C switches.
- Long-life resistive element potentiometers, Hall-effect position sensor and Hall-effect PCB
- Hall-effect PCB meets or exceeds CE EMC requirements

Options:

- Large selection of multi-function handles with rocker switches, push-buttons, and triggers, or mechanical interlock
- Variety of standard and special handle restricting gates available
- Large selection of proportional outputs including potentiometer, Hall-effect, PWM and CAN bus
- Bang / Bang design
- Special potentiometers
- Redundant Hall-effect output
- Hall-effect input voltage options



XL-VNSO POTENTIOMETERS AND CONTACTS

ORDERING INFORMATION

Drive Arrangement: Single axis and double axis – horizontal
Basic Assembly: 5.5" shaft length and boot supplied standard
Handle: 2 piece standard
Handle Action: Spring return
Output: Proportional, discrete or bang/bang
Output Devices: Potentiometer, PWM, CAN or 10A micro-switch

XL-VNSO TECHNICAL DATA

Mechanical:

- **Mechanical Life:** 20 million cycles
- **Gear Ratio:** 3.5:1
- **Detented Positions:**
Not available with XL-VNSO, use VNSO
- **Handle Travel:**
 - $\pm 36^\circ$ for proportional
 - $\pm 20^\circ$ for Bang/Bang
- **Potentiometer Rotation:** $\pm 126^\circ$

Environmental:

- **Operating Temperature:** -25 to +70°C
- **Storage temperature:** -40 to +70°C
- **Protection above the panel:** IP55

Electrical:

- **Contacts:** 11A 125, 250 VAC Form C V7 micro-switch (3 max. each axis) with .187" quick connect tab
- **Potentiometers:** Conductive Plastic, 0.5 watt 5K 3-wire or 10K 4-wire center tap, 5 million revolutions
Connections: 20 AWG UL1430 wire with Molex connector (03-06-2042)
- **Electronics:** PWM Amplifiers, Pot Amplifiers, Motor Control, CAN Bus
Connections: Varies with product

Options:

- **Handle:** See handle section for a selection of handle options
- **Shaft Length:** 4.125" and 7.125"
- **Handle Action:** Friction brake and maintained action are not available with XL-VNSO, use VNSO
- **Mounting:** See mounting section for a selection of mounting options
- **Gates:** Variety of standard and special handle restricting gates available
- **Special Pots:** Please consult factory with special potentiometer requirements

Please consult factory for other available options not listed.

XL-VNSO WITH POTENTIOMETER & CONTACTS OVERALL DIMENSIONS

XL-VNSO PANEL MOUNTING DETAIL

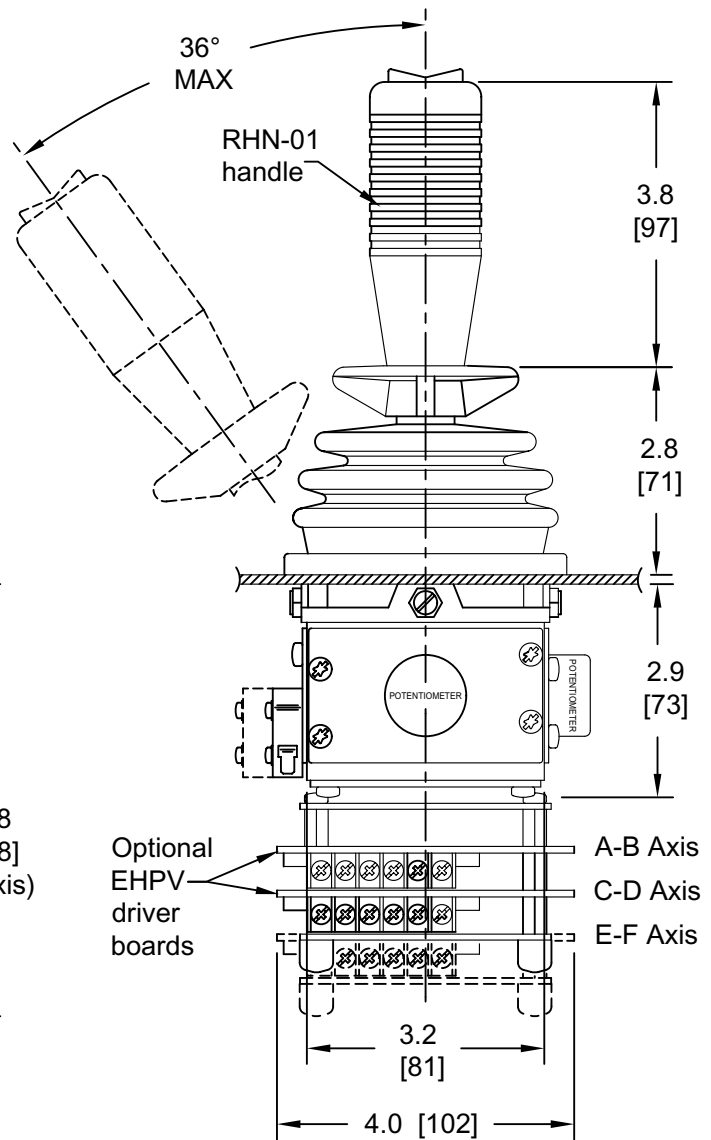
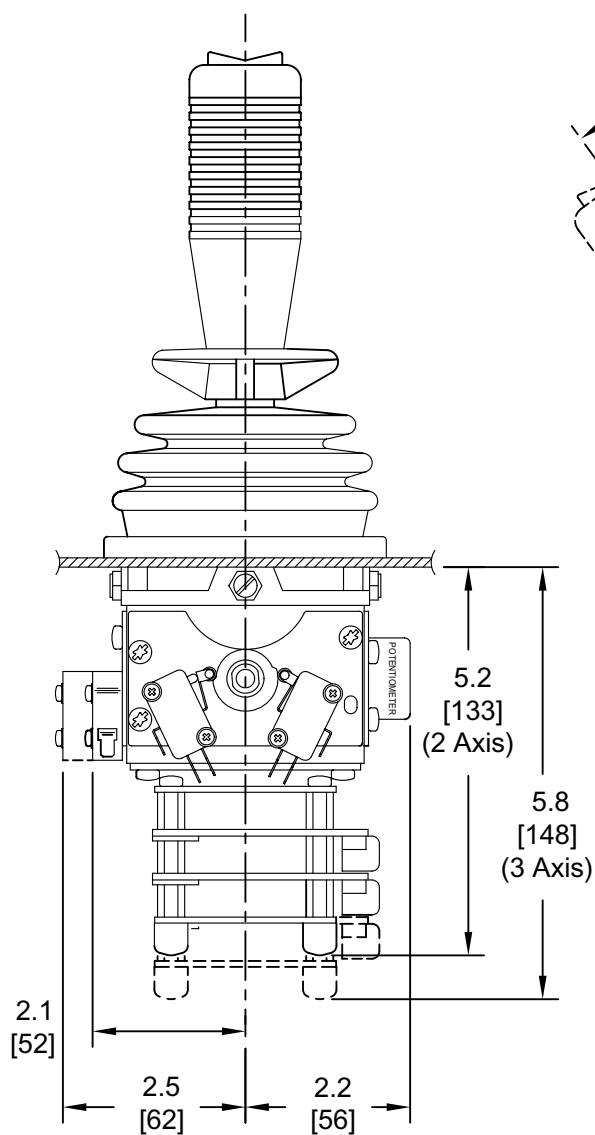
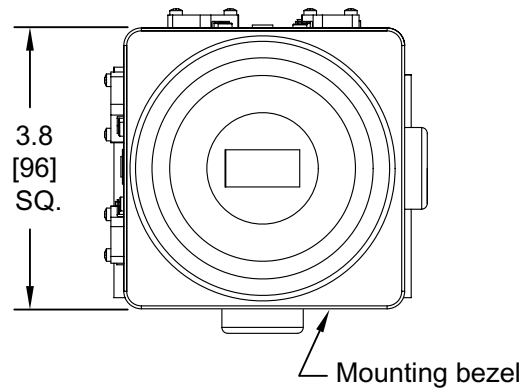
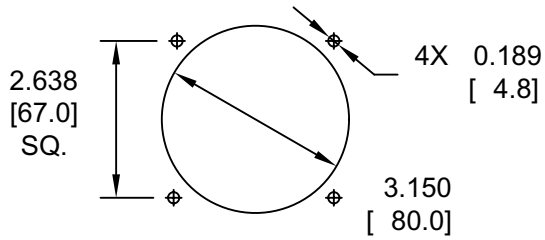

(Consult factory for other handle options)

XL-VNSO HALL-EFFECT ORDERING INFORMATION

Drive Arrangement:	Single axis and double axis – horizontal
Basic Assembly:	5.5" shaft length and boot supplied standard
Handle:	2 piece standard
Handle Action:	Spring return
Output:	Proportional Hall-effect position sensor
Output Devices:	Hall-effect PCB
Immunity:	Meets or exceeds CE requirements (Hall-effect PCB only)

XL-VNSO HALL-EFFECT TECHNICAL DATA

Mechanical:

- **Mechanical Life:** 20 million cycles
- **Gear Ratio:** 3.5:1
- **Detented Positions:**
Not available with XL-VNSO, use VNSO
- **Handle Travel:**
 - $\pm 36^\circ$ for Hall-effect position sensor
 - $\pm 20^\circ$ for Hall-effect PCB
- **Hall-Effect Position Sensor Rotation:** $\pm 126^\circ$

Environmental:

- **Operating Temperature:** -25 to +70°C
- **Storage temperature:** -40 to +70°C
- **Protection above the panel:** IP55
- **Hall-Effect PCB EMC Emissions:**
Complies with **EN61000-6-4:2007**
Class A Group 1, 80 – 1000 MHz
- **Hall-Effect PCB EMC Immunity:**
Complies with or exceeds
EN61000-6-2:2005 expanded to include:
RFI Immunity of 100 V/M @ 80 – 1000 MHz
ESD Immunity of 15 Kv air, 8 Kv contact

Please consult factory for other available options
not listed.

Electrical:

- **Hall-Effect PCB:**
Supply Voltage: 4.5 to 5.5VDC
Output Voltage: Ratiometric 0.5 – 2.5 – 4.5V $\pm 0.15V$
@ 5.0V supply
Output Current: 10mA
Power Consumption: 20mA @ full load
Connections: 4 position terminal block with #6 screw terminal
- **Hall-Effect Position Sensor:**
Supply Voltage: 4.5 to 5.5VDC
Output Voltage: Ratiometric 0.5 – 2.5 – 4.5V $\pm 0.15V$
@ 5.0V supply
Output Current: 8mA
Power Consumption: 19mA @ full load
Connections: 20 AWG UL1430 wire with Molex connector (03-06-2042)

Options:

- **Handle:** See handle section for a selection of handle options
- **Shaft Length:** 4.125" and 7.125"
- **Handle Action:** Friction brake and maintained action are not available with XL-VNSO, use VNSO
- **Mounting:** See mounting section for a selection of mounting options
- **Gates:** Variety of standard and special handle restricting gates available
- **Hall-Effect PCB:**
 - Option 1:**
Supply Voltage: 7 to 30VDC
Output Voltage: 0.5 – 2.5 – 4.5V $\pm 0.15V$
Connections: 4 position terminal block with #6 screw terminal
 - Option 2:**
Supply Voltage: 4.5 to 5.5VDC
Output Voltage: Redundant – ratiometric 0.5 – 2.5 – 4.5V $\pm 0.15V$ complementary @ 5.0V supply
Connections: 6 position terminal block with #6 screw terminal

XL-VNSO WITH HALL-EFFECT PCB OVERALL DIMENSIONS

SINGLE SENSOR

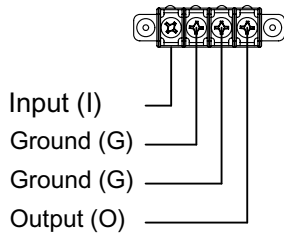

REDUNDANT

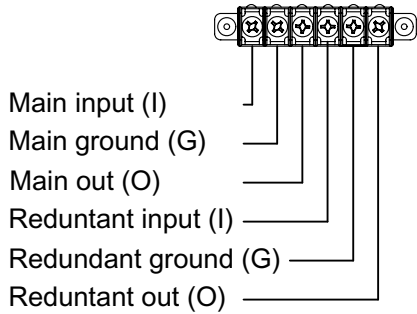

XLVNSO-E (Single axis)

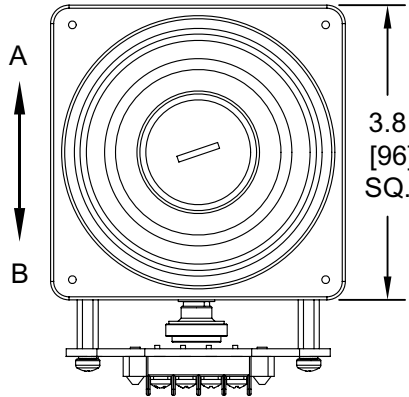
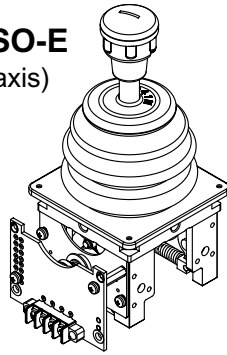

XLVNSO-V (Dual axis)

