

## Dual Output Super-mini Signal Conditioners Pico-M Series

### CURRENT LOOP SUPPLY

#### Functions & Features

- Powering a 4 – 20 mA DC current loop
- Two isolated process signal outputs
- Space-saving, easy-to-maintain, multi-channel installation base

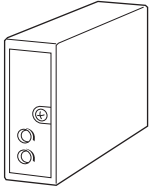

### MODEL: M8DY-[1][2]-R[3]

#### ORDERING INFORMATION

- Code number: M8DY-[1][2]-R[3]
- Specify a code from below for each of [1] through [3].  
(e.g. M8DY-6A0-R/Q)
- Specify the specification for option code /Q  
(e.g. /C01 /V01)

#### INPUT

Current

4 – 20 mA DC (Input resistance 250 Ω)

#### [1] OUTPUT 1 / OUTPUT 2

- 6A:** 1 – 5 V DC (Load resistance 2500 Ω min.)  
/ 4 – 20 mA DC (Load resistance 300 Ω max.)
- 44:** 0 – 10 V DC (Load Resistance 5000 Ω min.)  
/ 0 – 10 V DC (Load Resistance 5000 Ω min.)
- 55:** 0 – 5 V DC (Load resistance 2500 Ω min.)  
/ 0 – 5 V DC (Load resistance 2500 Ω min.)
- 66:** 1 – 5 V DC (Load resistance 2500 Ω min.)  
/ 1 – 5 V DC (Load resistance 2500 Ω min.)

#### [2] TRANSMITTER POWER SUPPLY SWITCH

0: Without

1: With

#### POWER INPUT

DC Power

R: 24 V DC

(Operational voltage range 24 V ±10 %, ripple 10 %p-p max.)

#### [3] OPTIONS

blank: none

/Q: With options (specify the specification)

#### SPECIFICATIONS OF OPTION: Q (multiple selections)

COATING (For the detail, refer to our web site.)

/C01: Silicone coating

/C02: Polyurethane coating

/C03: Rubber coating

ADJUSTMENT

/V01: Multi-turn fine adjustment

#### RELATED PRODUCTS

- Installation Base or Single Mount Base Socket (model: M8BSx)

This unit must be mounted on dedicated base or socket.

#### GENERAL SPECIFICATIONS

Construction: Plug-in

Mounting screw: M3 screw (torque 0.3 N·m)

Housing material: Flame-resistant resin (black)

Power supply: Via the Installation Base terminals  
(model: M8BSx)

Isolation: Input to output 1 to output 2 to power

Zero adjustment: -2 to +2 % (front)

Span adjustment: 98 to 102 % (front)

Transmitter power supply switch: Stops power supply at OFF  
(factory setting: ON)

#### SUPPLY OUTPUT

Output voltage: 24 – 28 V DC with no load

Current rating: ≤ 22 mA DC

- Shortcircuit Protection

Current limited: 30 mA max.

Protected time duration: No limit

#### INPUT SPECIFICATIONS

- DC Current: Input resistor incorporated

#### INSTALLATION

Current consumption: Approx. 60 mA

Operating temperature: 0 to 55°C (32 to 131°F)

Operating humidity: 30 to 95 %RH (non-condensing)

Mounting: Installation Base (model: M8BSx)

Weight: 70 g (2.5 oz)

#### PERFORMANCE in percentage of span

Accuracy: ±0.1 %

Temp. coefficient: ±0.02 %/°C (±0.01 %/°F)

**Response time:**  $\leq 15$  msec. (0 - 90 %)

**Line voltage effect:**  $\pm 0.1$  % over voltage range

**Insulation resistance:**  $\geq 100$  M $\Omega$  with 500 V DC

**Dielectric strength:**

1500 V AC @1 minute (input to output 1 or output 2 or power to ground)

500 V AC @1 minute (output 1 to output 2 to power)

**SWC test:** ANSI/IEEE-C37.90.1-1989

## BOTTOM VIEW

### • Transmitter Power Supply Switch

This switch is provided only when the option is specified in ordering. Turn the switch right for ON, left for OFF.

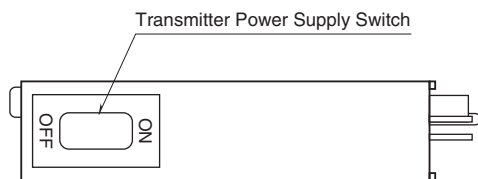

## EXTERNAL DIMENSIONS unit: mm [inch]

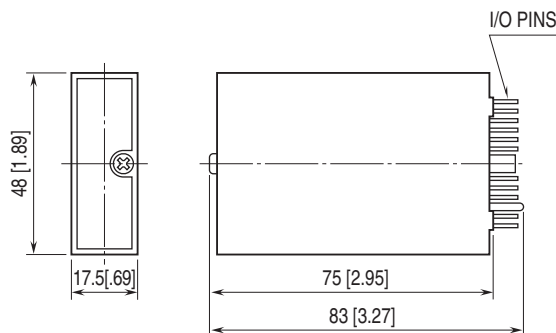

## SCHEMATIC CIRCUITRY & CONNECTION DIAGRAM

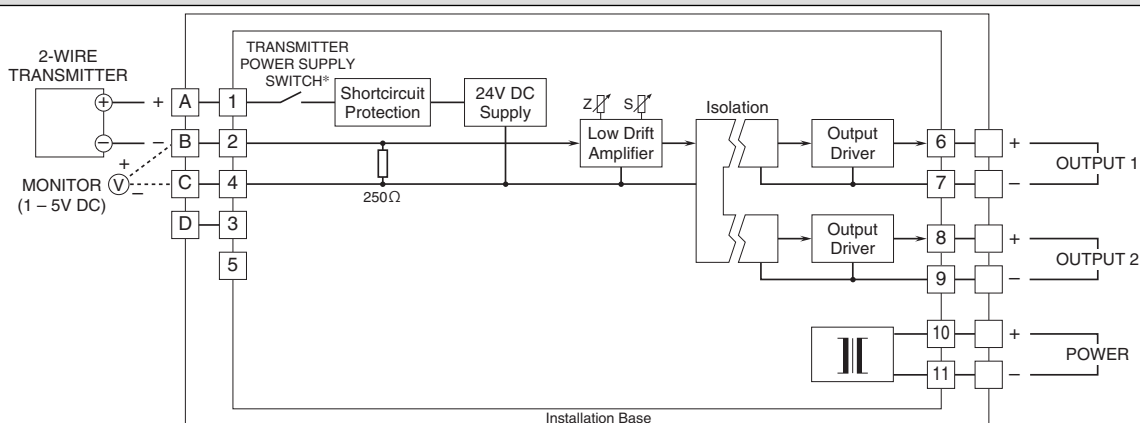

\*Provided only when the option is selected.

■ When Used as DC Supply

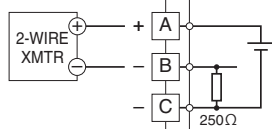

■ When Used as Isolator

