

# DELTA DKR

DOUBLE SEAT BALL VALVE



Engineering excellence, allied to stringent quality control, ensures that SPX's unrivalled range of APV products complies with the highest international standards for hygiene. In the light of growing pressure worldwide to deliver safe, high quality food, all SPX products are designed for easy cleanability, while minimizing the use of valuable resources, such as energy. The APV product portfolio includes a wide range of pumps, valves, heat exchangers, mixers and homogenizers designed for use in the food, dairy and brewing industries, as well as in chemical, healthcare, pharmaceutical processing and heavy industries.

SPX is highly committed to delivering sustainable solutions, which exceed customer expectations in value and return through a focus on.

- Waste prevention and loss reduction
- Reuse of resources
- Improved value of raw materials
- Water and energy reduction
- Product safety and security
- Social responsibility

It's hard to find a more comprehensive portfolio of processing equipment anywhere else. Many of our designs incorporate patented features and our research and development efforts continue to produce ground breaking technologies. When you specify our equipment you get more than a product – you get a partner.

# Double Seat Ball Valves

## PRODUCT BENEFITS AND FEATURES

### Safe Separation of Incompatible Fluids

A design with two seat seals and a drainable separation cavity ensuring timely discovery of any leakage due to seal failure, makes the DELTA DKR valve ideal for applications where safeguarding against mixing of different media has the highest priority.

### Highly Cleanable

The design is characterized by careful sealing with FDA compliant materials and the use of high-quality stainless steel. The CIP cleanability, including the leakage chamber between the housing globe and the ball, has been validated by an EHEDG test. Furthermore, steam sterilization of the leakage chamber is possible.

### Water Hammer Safe

In process systems, water hammers can occur. Due to a design with two welded shafts, the DELTA DKR can withstand water hammers. The soft opening and closing characteristic of the valve prevent the DELTA DKR from causing water hammers as well.

### No Pressure Drop

The DELTA DKR valves have spherical switching elements. When the valve is in the open position, a full bore will be achieved, i.e. no stem or disc to disturb the flow and virtually no pressure losses over the valve.

### Suitable for Use in Pigging Systems

The full ported, straight-through design frees the flow from obstructions and makes the DELTA DKR valve the obvious choice for pigging systems. DELTA DKR valves are used in process lines as well as in pig launching and receiving areas.

### Space-Saving Design

The compact design minimizes space requirements thus enabling efficient process designs. Furthermore, no auxiliary valve is required to open or close the leakage chamber.

# Typical product applications

## THEORY OF OPERATION

The field of application of the DELTA DKR valve comprises separation of two line sections with different fluids by two independent seals with an intermediate leakage chamber and a free drain to the atmosphere.

During operation, leakages drain off from the leakage discharge.

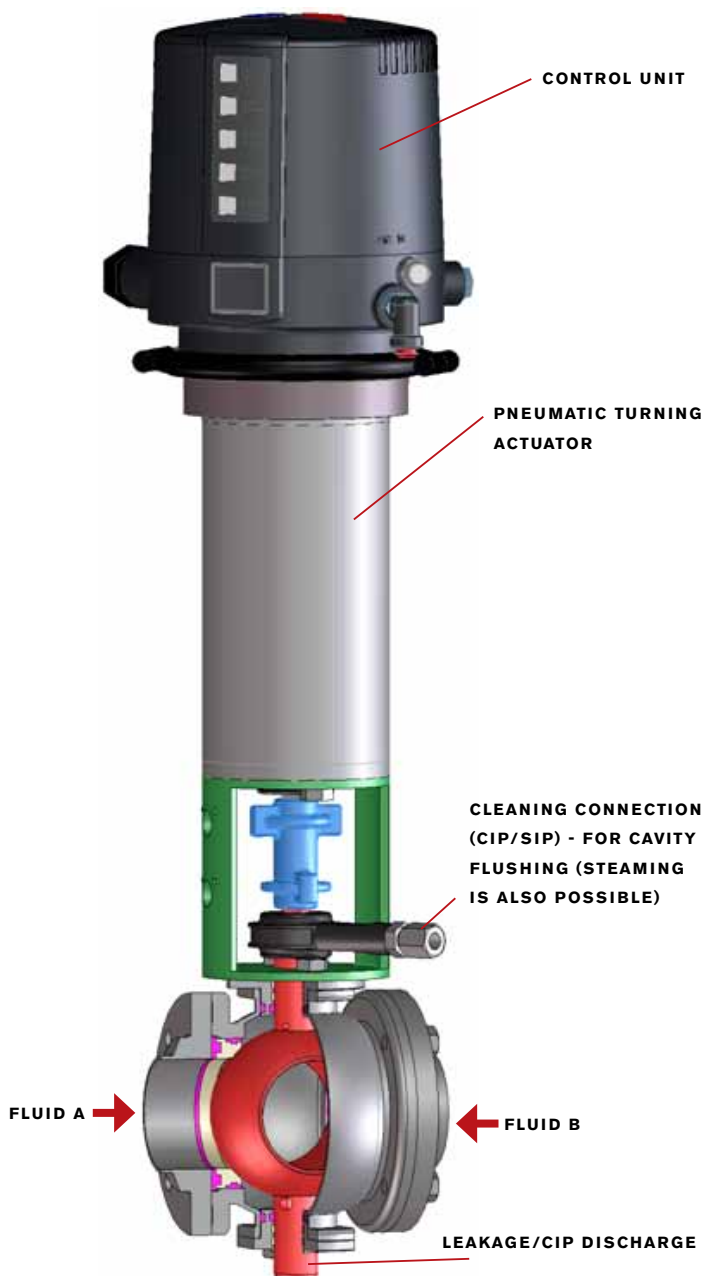

The leakage chamber is cleaned by supply of cleaning liquids via the cleaning connection. The leakage chamber can be flushed with water or CIP liquids or sterilized with steam.

DELTA DKR valves are generally suitable for applications involving viscous products or products with large solids.

### Beverage

- Fruit juice
- Liquid sugar
- Yeast
- Cider



### Food

- Mayonnaise
- Chocolate
- Soups and sauces
- Fruit preserves



### Dairy

- Cream
- Butter
- Margarine
- Cheese curd
- Cottage cheese



### Pharmaceuticals & Toiletries

- Sugar solutions
- Protein solutions
- Toothpaste
- Shampoo



# Product Specifications

## DELTA DKR DESIGNS AVAILABLE

TYPE	
DELTA DKR	STANDARD VALVES FOR VERTICAL INSTALLATION
DELTA DKRT	TANK OUTLET VERSION
DELTA DKRH	FOR HIGH PRESSURE APPLICATIONS

## MATERIALS

VALVE PARTS	MATERIALS
HOUSING, VALVE BALL, SHAFTS	1.4404 / AISI 316L
OTHER METALLIC PARTS	1.4301 / AISI 304 (NOT PRODUCT WETTED)
BALL SEAL	PTFE
FLANGE SEAL	EPDM (FDA COMPLIANT); OPTIONAL: HNBR, FPM, VMQ (FDA COMPLIANT)
HOUSING SEAL	EPDM (FDA COMPLIANT); OPTIONAL: HNBR, FPM (FDA COMPLIANT)

## TECHNICAL DATA

FUNCTIONALITY	MIX PROOF, SHUT-OFF
SIZES	DELTA DKR: DN25 TO DN150; 1" TO 4" DELTA DKRT: DN50, DN80, DN100 DELTA DKRH: DN50, DN80
MAX. LINE PRESSURE	DELTA DKR: 10 BAR (145 PSI) DELTA DKRT: 10 BAR (145 PSI) DELTA DKRH: 100 BAR (1450 PSI)
MAX. OPERATING TEMPERATURE	EPDM, HNBR, FPM, VMQ: 135°C / 275°F VMQ & FPM SHOULD NOT BE USED WITH HOT WATER/STEAM
MAX. STERILISATION TEMPERATURE (SHORT TERM)	EPDM, HNBR, FPM, VMQ: 140°C / 284°F VMQ & FPM SHOULD NOT BE USED WITH HOT WATER/STEAM
MIN. CONTROL AIR PRESSURE	6 BAR / 87 PSI
MAX. CONTROL AIR PRESSURE	10 BAR / 145 PSI
ACTUATOR	STAINLESS STEEL AND MAINTENANCE-FREE

# Options & Accessories

## DELTA DKRT

The DELTA DKRT is a special tank outlet version of the DKR valve. With a full ported and compact design the valves are particularly suitable for efficient emptying of tanks with low outlet heights.

## DELTA DKRH

The DELTA DKRH is a high-pressure version of the DELTA DKR valve. The valve's sturdy construction increases max. permissible line pressure in open or closed position to 100 bar (1450 PSI). Application examples are butter and mayonnaise production.

## DELTA DKR FOR HORIZONTAL INSTALLATION

DELTA DKR valves are also available for horizontal installation in horizontal as well as vertical pipelines.



DELTA DKRT



DELTA DKRH

Horizontal Installation in Horizontal Pipeline

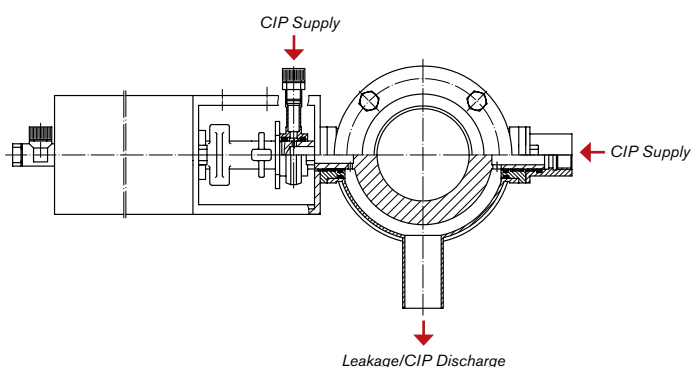

HORIZONTAL INSTALLATION IN VERTICAL PIPELINE

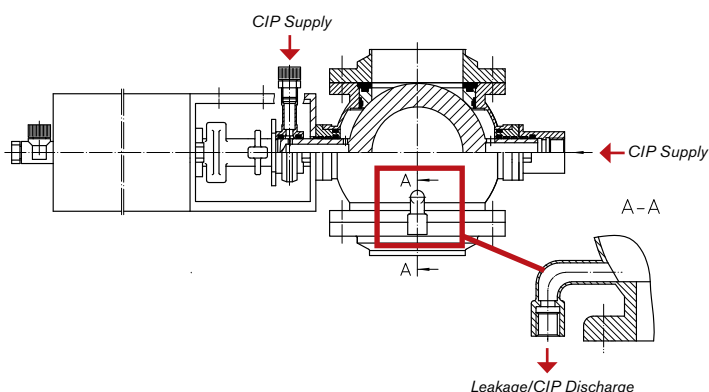

## DELTA DKR WITH LEAKAGE REDUCER

It is possible to reduce leakage during the opening and closing of the DELTA DKR valve by approximately 40% when installing a leakage reducer. The leakage reducer is especially suitable for CIP applications and can be retrofitted to installed valves as well.

## DELTA DKR WITH LEAKAGE COLLECTOR

The leakage discharge on DELTA DKR valves can be prepared for connection with a pipeline collecting liquid discharged during operation. Weld end as well as various pipe connections can be selected.

# Options & Accessories

## DELTA DKR WITH THERMAL JACKET

A special version of the DELTA DKR valve is available for applications involving temperature sensitive media, e.g. chocolate. The design facilitates the heating of the valve ball.

## CERTIFICATION OF MATERIALS

DELTA DKR can be delivered with EN10204 - 3.1 as well as USP Class VI certification.

## DELTA CU CONTROL UNIT

DELTA DKR valves are available with proximity switch holder for external proximity switches or a control unit.

The DELTA CU control units, used on various APV valve lines, are also available with the DELTA DKR valves. The control unit operates as interface between process control and valve and controls the electric signals and pneumatics.

APV DELTA CU control units are very robust, easy to maintain, and designed to operate in tough environments. Signal data are easily visible on an exterior LED (electronic lights).

### Interface Options

- CU4 Direct Connect (hard wire)
- CU4 AS-Interface, 31 or 62 slaves
- Profibus and DeviceNet (DELTA CU3)

### Position Indication

- 2 internal feedback sensor switches for valve open/valve closed position detection

### Solenoid Valves

- 1 Solenoid

### Protection Class

- IP67
- NEMA 6

DELTA DKR with Thermal Jacket

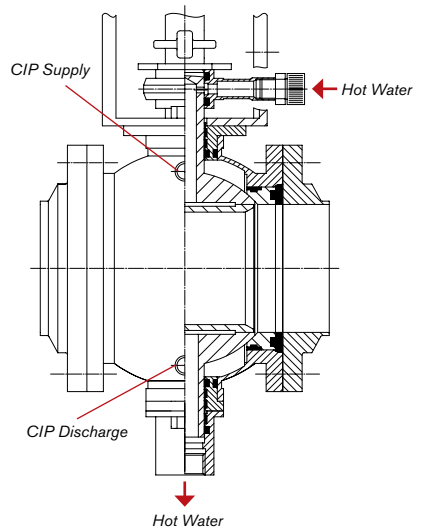

# Dimensional Data

## DELTA DKR

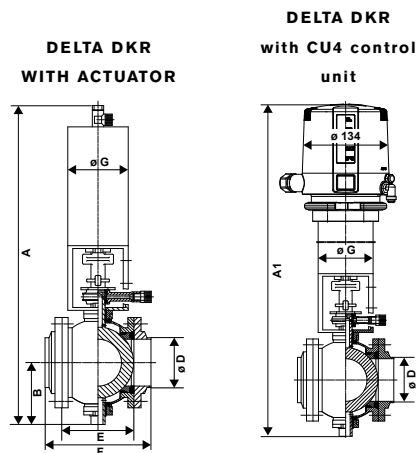

VALVE SIZE	MM							WEIGHT
	A	A1	B	ØD	E	F	ØG	KG
DN25	384	534	55	26	60.5	109	85	5.7
DN40	408	558	65	38	61	109	85	6.5
DN50	425	575	75	50	79	127	85	7.4
DN65	448	599	87	66	100.3	149	85	9.2
DN80	543	695	103	81	123	171	135	18.0
DN100	572	724	117	100	150	198	135	21.5
DN125	663	815	142	125	190	244	189	40.0
1"	384	534	55	22.6	60.5	109	85	5.7
1.5"	408	558	65	34.9	61	109	85	6.5
2"	425	575	75	47.6	79	127	85	7.4
2.5"	448	599	87	60.3	100.3	149	85	9.2
3"	543	695	103	72.9	123	171	135	18.0
4"	572	724	117	97.6	150	198	135	21.5

## DELTA DKRT

**DELTA DKRT with CU4 control unit**

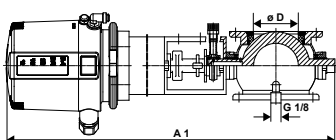

**DELTA DKRT with actuator**

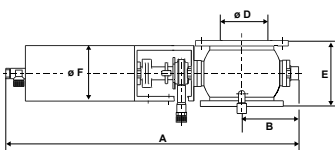

VALVE SIZE	MM						WEIGHT
	A	A1	B	ØD	E	ØF	KG
DN50	427	575	75	50	79	85	6.0
DN80	543	695	103	81	123	135	16.0
DN100	574	724	117	100	150	135	19.0

## DELTA DKRH

**DELTA DKRH with actuator**

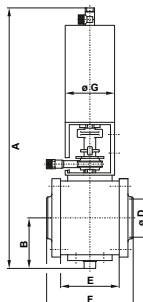

**DELTA DKRH with CU4 Control Unit**

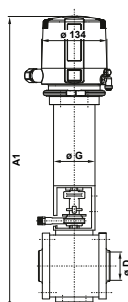

VALVE SIZE	MM							WEIGHT
	A	A1	B	ØD	E	F	ØF	KG
DN50	447	597	86.5	50	79	127	85	13.0
DN80	565	717	113.5	81	123	203	135	34.0