

PC*5 Flow Regulator
Female-to-Female

IN-LINE

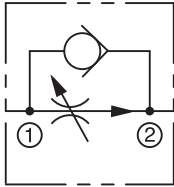

DESCRIPTION

Pneu-Trol pressure compensated constant flow regulator valves are exceptionally accurate in maintaining constant flow with pressures up to 3,000 psi (207 bar). These adjustable valves, while under pressure, allow infinite output flow adjustment within a specified flow range independent of inlet pressure variations. An internal check valve to bypass the control orifice provides unrestricted free reverse flow.

The compensating action of these valves results from an adjustable orifice at the inlet end and a series of variable orifices at the outlet end. Flow through the variable orifices is controlled by a spring and piston. These elements work together to regulate hydraulic flow within the determined rates. Flows are controlled within $\pm 15\%$ up to 1.5 gpm (5.7 lpm) and $\pm 10\%$ at higher flow up to 15.0 gpm (56.8 lpm). Regulation is virtually unaffected by temperature changes from 60° F (16° C) to 180° F (82° C). At a temperature differential $[\Delta T]$ of 70° F (21° C) flow variation would be approximately $\pm 2\%$ max; while at temperature differential $[\Delta T]$ of 120° F (49° C) the flow variation would be approximately $\pm 4\%$ max.

Series 5 units are made from high-strength steel. The standard porting of these valves is NPTF with optional SAE and BSPT threads available on selected models.

- **Maintains accurate constant flow at pressures up to 3,000 PSI (207 Bar)**
- **Adjustable flow**
- **Lock Nut to maintain flow setting**
- **Free reverse flow**

FLOW RATING

SERIES 5

NPT Thread

Size	Controlled Flow Range gpm (lpm)	Min. Oper. Press. ΔP (Δ bar)
1/4"	0.75 to 5.0 (2.8 to 18.9)	100 - 300 (6.9 to 20.7)
3/8"	1.0 to 10.0 (3.8 to 37.9)	100 - 200 (6.9 to 13.8)
1/2"	1.5 to 15.0 (5.7 to 56.8)	200 (13.8)

ISO 7/1 - RS - BSP Taper Thread

Size	Controlled Flow Range gpm (lpm)	Min. Oper. Press. ΔP (Δ bar)
1/4"	0.75 to 5.0 (2.8 to 18.9)	100 - 300 (6.9 to 20.7)
3/8"	1.0 to 10.0 (3.8 to 37.9)	100 - 200 (6.9 to 13.8)
1/2"	1.5 to 15.0 (5.7 to 56.8)	200 (13.8)

SAE Thread

Size	Controlled Flow Range gpm (lpm)	Min. Oper. Press. ΔP (Δ bar)
SAE 8 (Size 3)	1.0 to 10.0 (3.8 to 37.9)	100 - 200 (6.9 to 13.8)
SAE 8 (Size 4)	1.5 to 15.0 (5.7 to 56.8)	200 (13.8)

SPECIFICATIONS

<p>Maximum Operating Pressure (Non-Shock Service) Carbon Steel: 3,000 psi (207 bar)</p> <p>Minimum Operating Pressure (See Flow Rating Chart)</p> <p>Operating Temperature Range -15° to +400° F (-26° to +204° C)</p> <p>Threads NPTF, BSPT, SAE</p>	<p>Materials</p> <p>Body, Adapter: Clear, Zinc-Plated Steel</p> <p>Spring: Music Wire</p> <p>Piston: Steel</p> <p>Housing: Brass</p> <p>Needle: Stainless Steel 416</p> <p>O-Rings: Viton</p> <p>Back-Up Washer: Teflon</p> <p>Lock Nut: Stainless Steel 303</p> <p>Knob: Blue Anodized Aluminum</p>
---	---

INSTALLATION DIMENSIONS

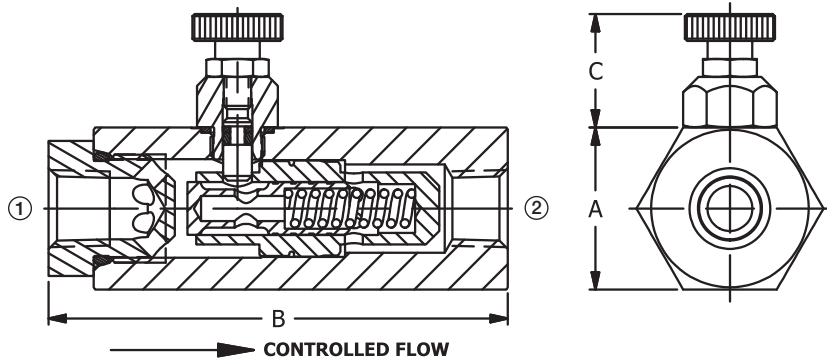

Pipe Size	A HEX	B	C Open	C Closed
1/4"	1-1/8 (28.6)	3-3/16 (81.0)	57/64 (22.6)	49/64 (19.5)
3/8"	1-1/2 (38.1)	3-3/4 (95.3)	1-5/32 (29.4)	15/16 (23.8)
1/2"	1-5/8 (41.3)	4-3/8 (111.1)	1-15/32 (37.3)	1-7/32 (31.0)

() Parentheses = Millimeters

HOW TO ORDER

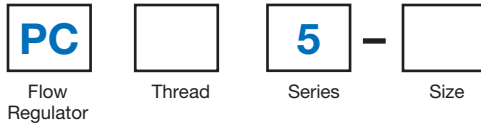

Code	Thread
Omit	NPT
B	BSPT
M8	SAE 8

Code	Size	
	NPTF/BSPT	SAE
2	1/4"	-
3	3/8"	SAE 8
4	1/2"	SAE 8

AVAILABLE MODEL CODES

Size	NPTF Thread	ISO 7/1 - RS — BSP Taper Thread	SAE Thread	Flow Range gpm (lpm)	Min. Oper. Press. ΔP (Δbar)
1/4"	PC5-2	PCB5-2	-	0.75 to 5.0 (2.8 to 18.9)	100 - 300 (6.9 to 20.7)
3/8"	PC5-3	PCB5-3	-	1.0 to 10.0 (3.8 to 37.9)	100 - 200 (6.9 to 13.8)
1/2"	PC5-4	PCB5-4	-	1.5 to 15.0 (5.7 to 56.8)	200 (13.8)
SAE 8	-	-	PCM85-3	1.0 to 10.0 (3.8 to 37.9)	100 - 200 (6.9 to 13.8)
	-	-	PCM85-4	1.5 to 15.0 (5.7 to 56.8)	200 (13.8)