

# Bailey

LOCAL DISTRIBUTOR

Simply photocopy and  
fax to us for more  
information on...

Please tick box  
where appropriate

Direct Acting Pressure Reducing Valves

700 Series Safety Relief Valves

Standard Safety Relief Valves

Associated Products

Birkett API/ASME Spring & Pilot SRV's

Amal Flame Arresters

Marston Bursting Discs & Explosion Vent Panels

Marvac Pressure/Vacuum Valves

Please complete the following

Name: \_\_\_\_\_

Position: \_\_\_\_\_

Company: \_\_\_\_\_

Address: \_\_\_\_\_  
\_\_\_\_\_  
\_\_\_\_\_

Post Code: \_\_\_\_\_

Tel No: \_\_\_\_\_

Fax No: \_\_\_\_\_

Email: \_\_\_\_\_



BAG40702



Registered Office: Sharp Street, Worsley,  
Manchester M28 3NA, UK.

# Bailey



## G4 Series

Pilot Operated  
Pressure  
Reducing  
Valves



# Bailey G4 Series

Pilot Operated Pressure Reducing Valves

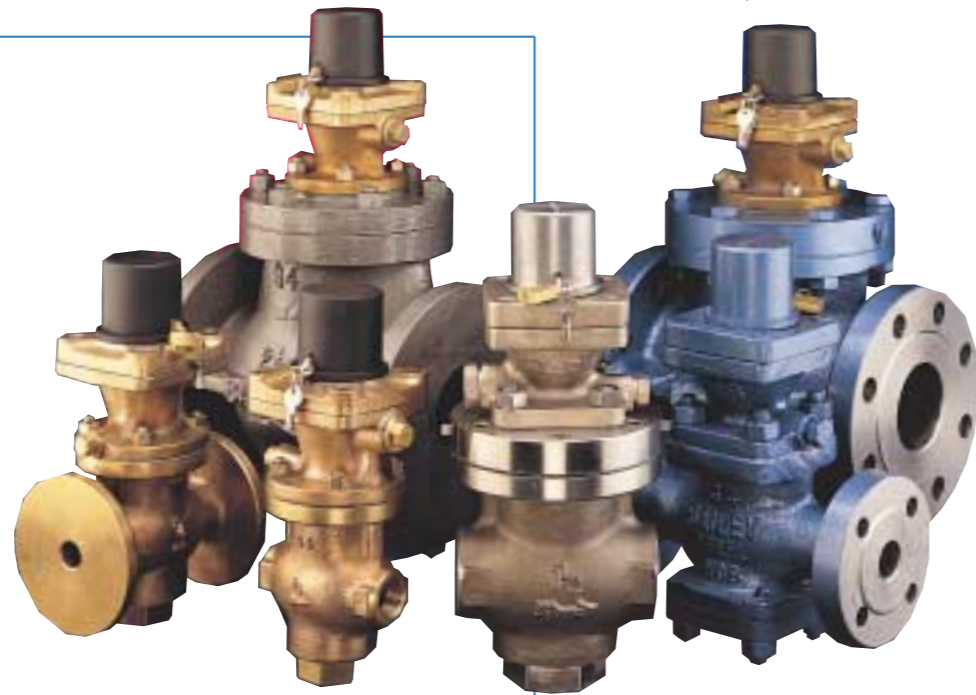

The Bailey 'G4' Series of pilot operated pressure reducing valves offers a comprehensive range for control of vital services such as steam, air and fine industrial gases. The 'G4' is a self acting, integral mounted pilot operated pressure reducing valve, which is designed to be extremely compact and versatile.

The 'G4' has become a symbol for accuracy of control, high performance, quality and reliability. The 'G4' has set the standard which all other pressure reducing valves strive to achieve.

Bailey can help to specify the most appropriate size and type of valve for any specific application.

## THE LOGICAL CHOICE

Experience, and focus on customer service, make Bailey the logical choice of supplier for pressure reducing and regulating valves, to accurately and continuously control pressures right around the clock and right around the world.

A policy of continuous improvement ensures that Bailey valves will always provide exceptional reliability and performance.

By choosing Bailey pressure reducing valves, you are selecting availability, quality, professional advice and proven performance - all delivered through an extensive worldwide network of distributors. Should a valve change-out be required at short notice, ex-stock availability of most standard valves ensures minimal plant downtime and maximum production.

## Bailey G4 Series

The complete solution  
with global support

## APPLICATIONS TABLE - G4 SERIES

APPLICATION	MATERIAL	SIZE	RECOMMENDED VALVE TYPE
Steam	Bronze	15 to 50mm	2042/3
	Cast Iron	65 to 150mm	2044
	Cast Steel	65 to 150mm	2045
	Cast Steel	15 to 150mm	2046
Clean Steam	Stainless Steel	15 to 50mm	2042/3 SS
Air and Fine Gas	Bronze	15 to 50mm	2042/3 GN
	Cast Iron	65 to 150mm	2044 GP
	Cast Steel	15 to 50mm	2046 GN
	Cast Steel	65 to 150mm	2045/6 GP
Oxygen and Methane	Bronze	15 to 50mm	2042/3 OV
Stainless Steel Environment	Stainless Steel	15 to 50mm	2042/3 SS
			2042/3 SN

Accurate selection of G4 valve type depends on: inlet/outlet pressure - capacity - material - temperature - fluid - connection required.

## FEATURES AND BENEFITS

- **Accuracy**, capable of regulating outlet pressure within +/-1/2%.
- **Integral pilot**, extremely compact design.
- **Self actuated**, no external power source required.
- **Fully balanced**, stability of control regardless of inlet pressure fluctuations.
- **Full lift capability**, maximum capacity/minimum size.
- **Positive shut off**, ensures leak free operation.
- **Rangeability**, wide choice of sizes, materials and connections.
- **Interchangeability**, many components are interchangeable between the various types and sizes, therefore easily adapted, metal/soft seats, high/low pressure.
- **World renowned**, over 30 years service experience in world wide industries.
- **Availability**, stocked world-wide by our comprehensive distributor network.
- **PED**, all valves are in full compliance with the PED.

## CONTENTS

	Page No.
Applications Table	2
Method of Operation	3
Gas and Oxygen Duties	4
Stainless Steel Version	4
Low Pressure Top	4
Sectional Diagram and Parts List	5
Materials	6
Remote Sensing/Balance Pipes	7
Spares Packs	7
Series and Parallel/Installations	8
Installation	9
Setting and Spring Selection	10
Sizing	11 - 12
Surplus and Maintaining Valves	13 - 14
Capacity Charts	15 - 16
Pipe Capacities/Pipe Selection	17 - 18
Technical Specifications	19 - 20
Dimensions	21

# Bailey G4 Series

Pilot Operated Pressure Reducing Valves

...Extremely sensitive and accurate

## OPERATION

The 'G4' pressure reducing valve is designed for use on steam, air and gases. It will maintain a constant outlet pressure irrespective of variations in the inlet pressure or demand from the system.

Initially with no compression on the adjusting screw, both the pilot and main valve seats are closed due to the action of the springs in the pilot and main valve. Fluid at the inlet pressure passes up the inlet relay port to the pilot valve seat which is opened by clockwise (viewed from above) rotation of the adjusting screw. This compresses the adjusting spring and applies load to the topside of the diaphragm, pushing open the pilot valve. Fluid now passes through the pilot valve seat, through the relay port to the top of the large diameter piston, which in turn pushes the main valve open.

The pressure of the fluid is reduced as it passes through the open main valve from the inlet to the valve outlet. At the same time fluid passes up the outlet relay port to the underside of the diaphragm, from where the outlet pressure is controlled.

The outlet pressure is a result of the balancing of the forces acting on the diaphragm, from the adjusting spring above and the reduced pressure from below.

The 'G4' is extremely sensitive and accurate, due to the large diaphragm. Inlet variations, or demand from the system, will attempt to affect the outlet pressure. Such attempts will result in movement of the pilot valve, which in turn minutely moves the piston and main valve seat. Thus the outlet pressure is maintained and the controlling cycle starts again. Such variations are so small they are virtually undetectable and as such, the outlet pressure can be considered constant.

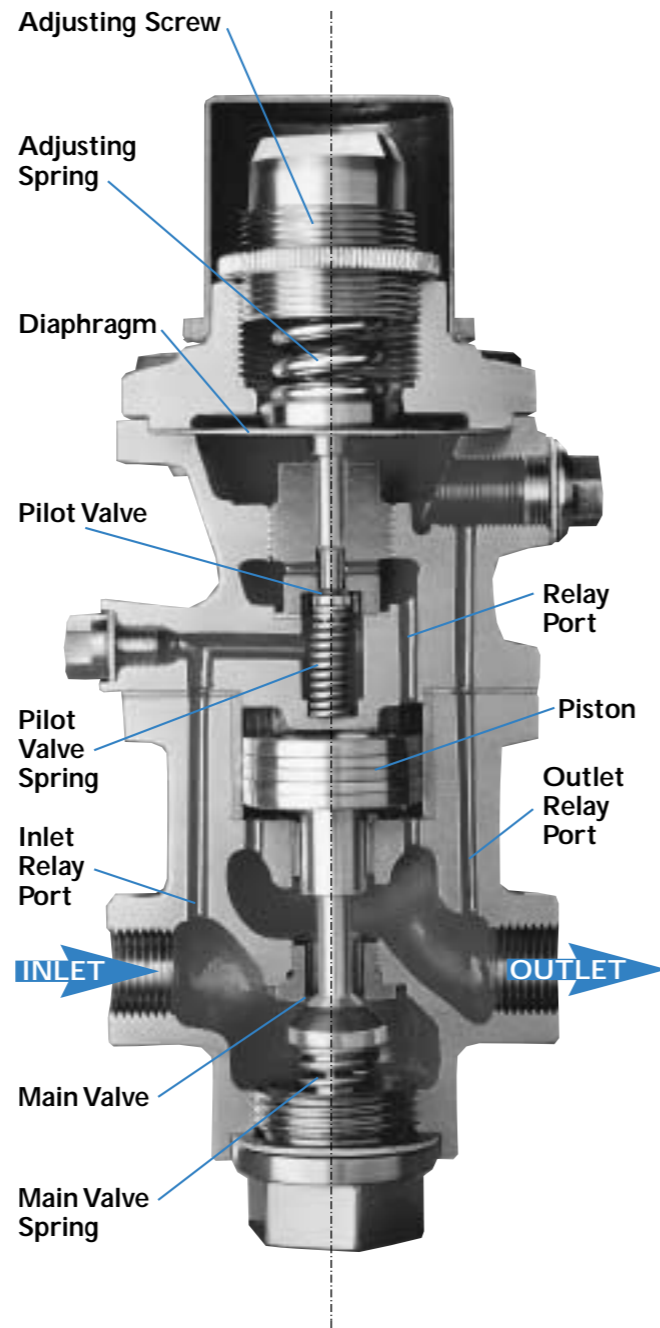

## GAS AND OXYGEN DUTIES

The 'G4' has successfully been used for many years with metal seats on demanding steam applications. However soft seated versions are available for industrial fine gas applications, involving such gases as carbon dioxide, nitrogen and oxygen. Typical application areas would include pharmaceuticals, food processing and brewing.

The 'G4' utilises a range of soft elastomer seat materials to meet the ever growing demand for these specialist applications.

In addition, valves for active gases, such as oxygen and methane, can be supplied fully assembled and tested to "oxygen service" standard in Bailey's state of the art clean room facility. This facility complies fully with the "Industrial Gas Committee" guidelines.

All soft seat options can also be supplied as **conversion kits**, allowing existing valves and stock to be modified quickly should the need suddenly arise.

## STAINLESS STEEL

The 'G4' is available in a fully stainless steel version, sizes 15 to 50mm, both screwed and flanged.

## Hygienic Environments

Changing regulations in the food, drink and pharmaceutical industries around the world, now often require all stainless steel pipe work systems to be used in hygienic environments, which in turn require the use of stainless steel pressure reducing valves.

## Clean Steam Applications

Regulations for hospitals, pharmaceutical, food and drink companies also require clean steam to be used for sterilisation and decontamination processes. Clean steam is very corrosive and requires stainless steel pressure reducing valves.

## LOW PRESSURE TOP

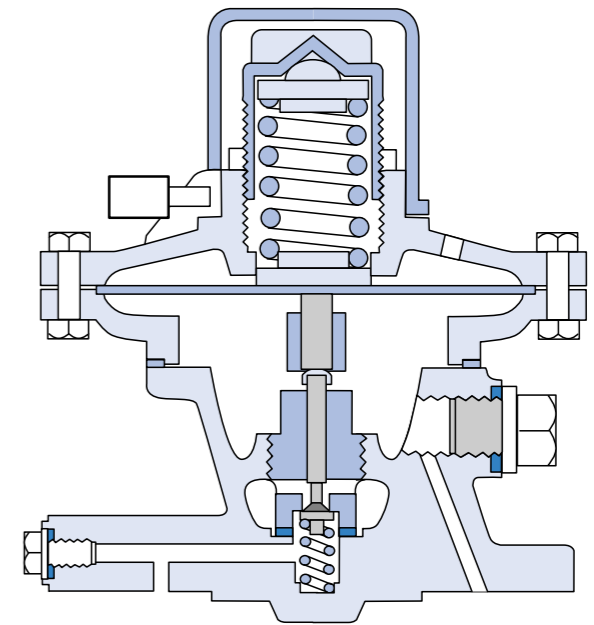

The standard 'G4' pilot top can reduce pressures down to 0.35 Barg (5 Psig). For pressures below this, a bronze low pressure pilot top can be fitted in place of the standard top. It is suitable for outlet pressures from 0.07 to 0.35 Barg (1 to 5 Psig) using the yellow spring. The low pressure top is available for fitting on to valve sizes 15 to 100mm (1/2 to 4 inch), and a balance line should always be fitted to a low pressure top, on steam duty and never on gas duty.

*Note: A low pressure top is only suitable for inlet pressure up to a maximum of 7 Barg (100 Psig). Higher inlet pressures can be accommodated by use of two G4 valves 'in-series', refer to page 8.*

The low pressure top can also be supplied as a **conversion kit**, allowing existing valves and stock to be modified quickly should the need suddenly arise.

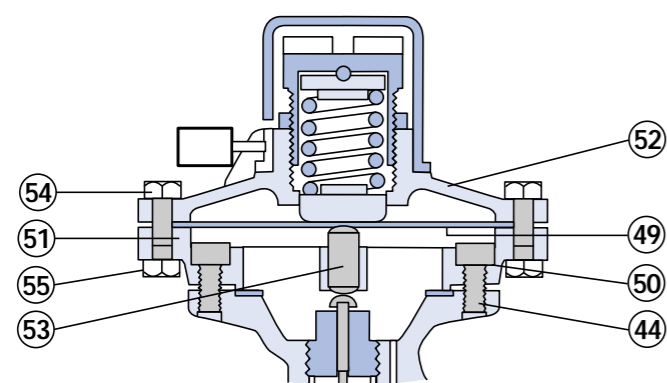
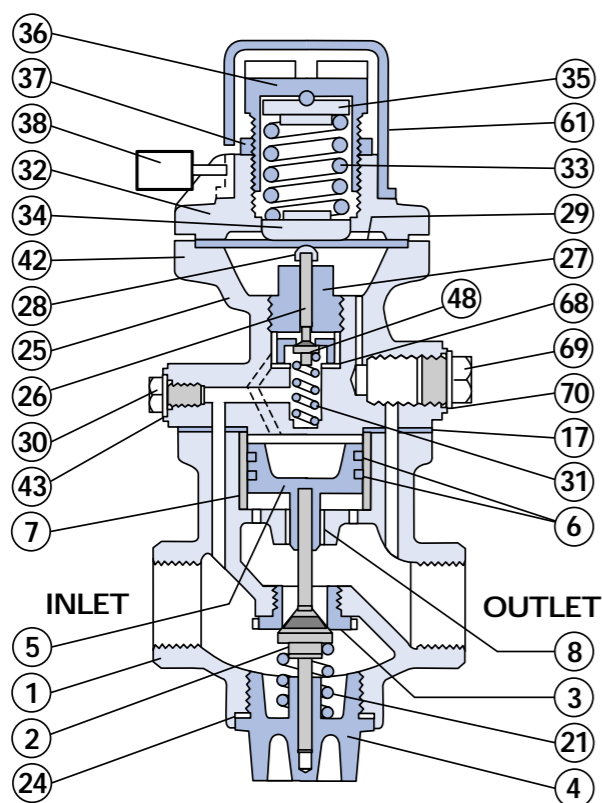
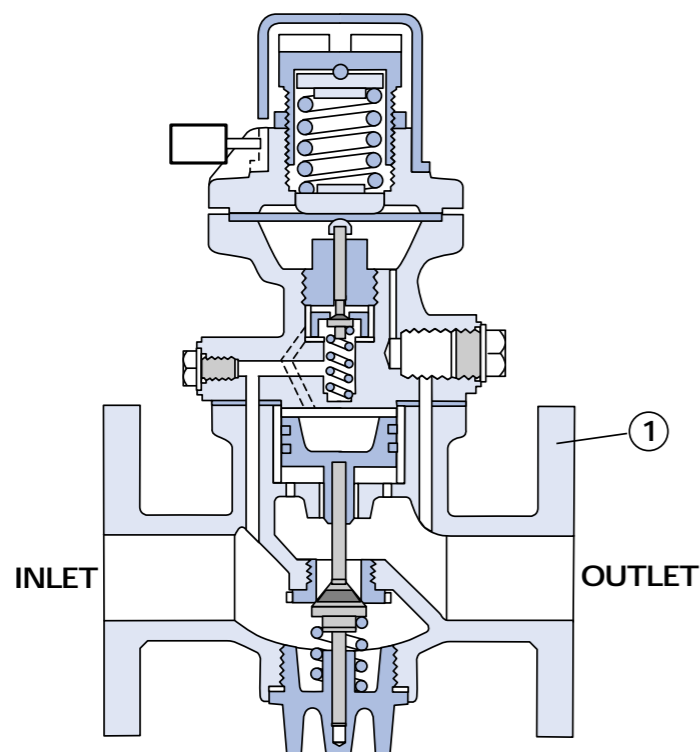

ITEM	PART
------	------

1	Body
2	Main Valve
3	Main Valve Seat
4	Bottom Plug
5	Piston
6	Piston Rings
7	Piston Liner
8	Piston Guide
17	Valve Body Top Joint
21	Main Valve Spring
24	Bottom Plug Joint
25	Pilot Valve Top
26	Pilot Valve
27	Pilot Valve Plug
28	Pilot Valve Cap
29	Diaphragm
30	H.P. Port Plug
31	Pilot Valve Spring
32	Pilot Valve Top Cover
33	Adjusting Spring
34	Adjusting Spring Bottom Plate
35	Adjusting Spring Top Plate
36	Adjusting Screw
37	Locking Ring
38	Padlock
42	Diaphragm Joint
43	H.P. Port Plug Joint
44	Cap Headed Screws
48	Pilot Valve Head
49	L.P. Diaphragm
50	L.P. Screw Joint
51	L.P. Adaptor Flange
52	L.P. Top Cover
53	L.P. Push Rod
54	L.P. Top Cover Bolts
55	L.P. Top Cover Nuts
61	Top Cap
68	Pilot Valve Plug Joint
69	Remote Control Plug
70	Remote Control Plug Joint

**Note:** Items 2 and 26 are Stainless Steel for steam duty, but on air and gas duties they have a variety of elastomeric or PTFE seats, to suit the application.

ITEM	2042 & 2043 Bronze	2042 & 2043 Stainless Steel	2044 Cast Iron	2045 Carbon Steel	2046 Carbon Steel
1	Bronze	Stainless Steel	Cast Iron	Carbon Steel	Carbon Steel
2	Stainless Steel	Stainless Steel	Stainless Steel	Stainless Steel	Stainless Steel
3	Stainless Steel	Stainless Steel	Stainless Steel	Stainless Steel	Stainless Steel
4	Bronze	Stainless Steel	Bronze	Stainless Steel	Stainless Steel
5	Bronze	Stainless Steel	Bronze	Bronze	Stainless Steel
6	Bronze	PTFE coated St. St.	Bronze	Bronze	Chrome Iron
7	Stainless Steel	Stainless Steel	Stainless Steel	Stainless Steel	Stainless Steel
8	Stainless Steel	Stainless Steel	Stainless Steel	Stainless Steel	Stainless Steel
17	NAF	NAF	NAF	NAF	NAF
21	Stainless Steel	Stainless Steel	Stainless Steel	Stainless Steel	Stainless Steel
24	NAF	NAF	NAF	NAF	NAF
25	Bronze	Stainless Steel	Bronze	Bronze	Steel
26	Stainless Steel	Stainless Steel	Stainless Steel	Stainless Steel	Stainless Steel
27	Stainless Steel	Stainless Steel	Stainless Steel	Stainless Steel	Stainless Steel
28	Brass	Stainless Steel	Brass	Brass	Brass
29	Stainless Steel	Stainless Steel	Stainless Steel	Stainless Steel	Stainless Steel
30	Bronze	Stainless Steel	Bronze	Bronze	Carbon Steel
31	Stainless Steel	Stainless Steel	Stainless Steel	Stainless Steel	Stainless Steel
32	Bronze	Stainless Steel	Bronze	Bronze	Carbon Steel
33	Steel	Stainless Steel	Steel	Steel	Steel
34	Brass	Stainless Steel	Brass	Brass	Brass
35	Brass	Stainless Steel	Brass	Brass	Brass
36	Bronze	Stainless Steel	Bronze	Bronze	Bronze
37	Bronze	Stainless Steel	Bronze	Bronze	Bronze
38	Brass	Brass	Brass	Brass	Brass
42	NAF	NAF	NAF	NAF	NAF
43	NAF	NAF	NAF	NAF	NAF
44	Steel	Stainless Steel	Stainless Steel	Stainless Steel	Stainless Steel
48	Stainless Steel	Stainless Steel	Stainless Steel	Stainless Steel	Stainless Steel
49	Bronze	N/A	Bronze	Bronze	N/A
50	Copper	N/A	Copper	Copper	N/A
51	Bronze	N/A	Bronze	Bronze	N/A
52	Bronze	N/A	N/A	N/A	N/A
53	Monel	N/A	Monel	Monel	N/A
54	Steel	N/A	Steel	Steel	N/A
55	Steel	N/A	Steel	Steel	N/A
61	Nylon	Zinc alloy	Nylon	Nylon	Nylon
68	Copper	NAF	Copper	Copper	Copper
69	Brass	Stainless Steel	Bronze	Bronze	Carbon Steel
70	NAF	NAF	NAF	NAF	NAF

## REMOTE PRESSURE SENSING

### For Steam Applications

The 'G4' is a self-actuated, pilot operated pressure reducing valve and it relies upon a stable pressure signal from the outlet pipe work in order to maintain stable control of the outlet pressure.

However, under certain conditions the signal pressure may be unstable in the immediate vicinity of the valve outlet and as a result may cause erratic control.

This can easily be overcome by installing a balance pipe from the remote sensing port to a straight section of the outlet pipe where stable flow has been resumed (see diagram below).

Ideally the balance pipe should be a minimum of 2 metres (6 feet) long and must be screwed into the remote sensing port to the required depth, see page 9. It should also include a pipe union and stop valve to allow dismantling and isolation. It should be installed with a steady fall away from the reducing valve, to facilitate self drainage of condensate.

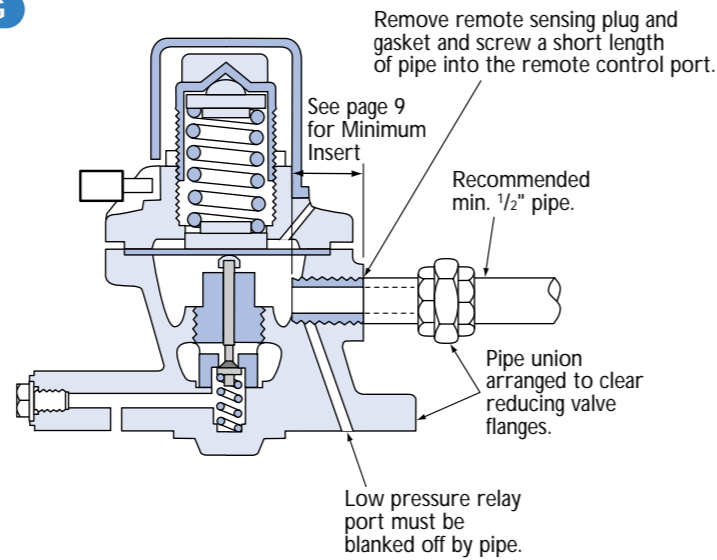
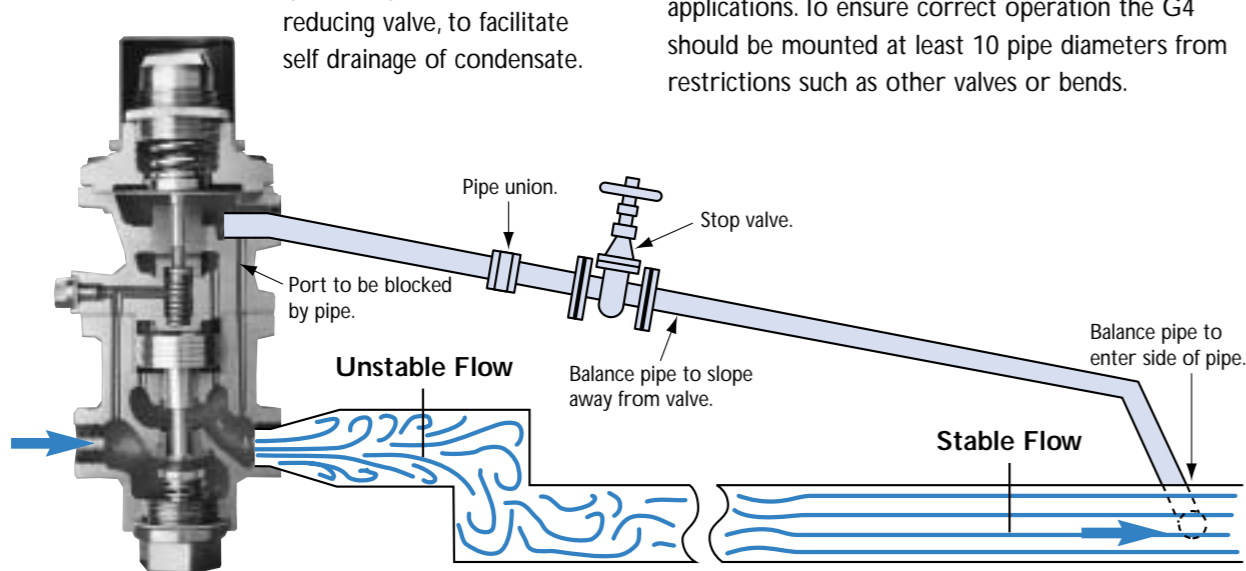

### We recommend fitting a balance pipe:

1. When the reduced pressure is below 55% of the inlet pressure.
2. When a low pressure top is fitted.
3. When difficult outlet pipe work conditions occur.

We do not recommend fitting a balance pipe on gas applications. To ensure correct operation the G4 should be mounted at least 10 pipe diameters from restrictions such as other valves or bends.

## SPARES

### Routine Service Pack:

- 1 Diaphragm
- 1 Set of Piston Rings
- 1 Pilot Valve Cap
- 1 Set of Joints

### Complete Repair kit:

- 1 Diaphragm
- 1 Set of Piston Rings
- 1 Pilot Valve Assembly
- 1 Main Valve
- 1 Main Valve Seat
- 1 Main Valve Spring
- 1 Set of Joints
- 1 Pilot Valve Cap



Each carton of spares contains a leaflet, which not only identifies the parts supplied, but also has a recommended list of 'check-points' to help identify common causes of reducing valve trouble.

## DIAPHRAGMS

One diaphragm is required for reduced pressures up to 10.5 Barg (150 Psig), but two are required for reduced pressure above this figure.

## 'IN SERIES' INSTALLATIONS

Multiple valves installed 'In Series' should be considered for applications when high pressure drops are required. If the required outlet pressure is less than the minimum shown in the charts two valves can be used.

An 'In Series' installation should be designed to drop the pressure in at least two steps/stages.

A typical diagram is shown (using globe type isolating valves).

### 'IN SERIES' INSTALLATION

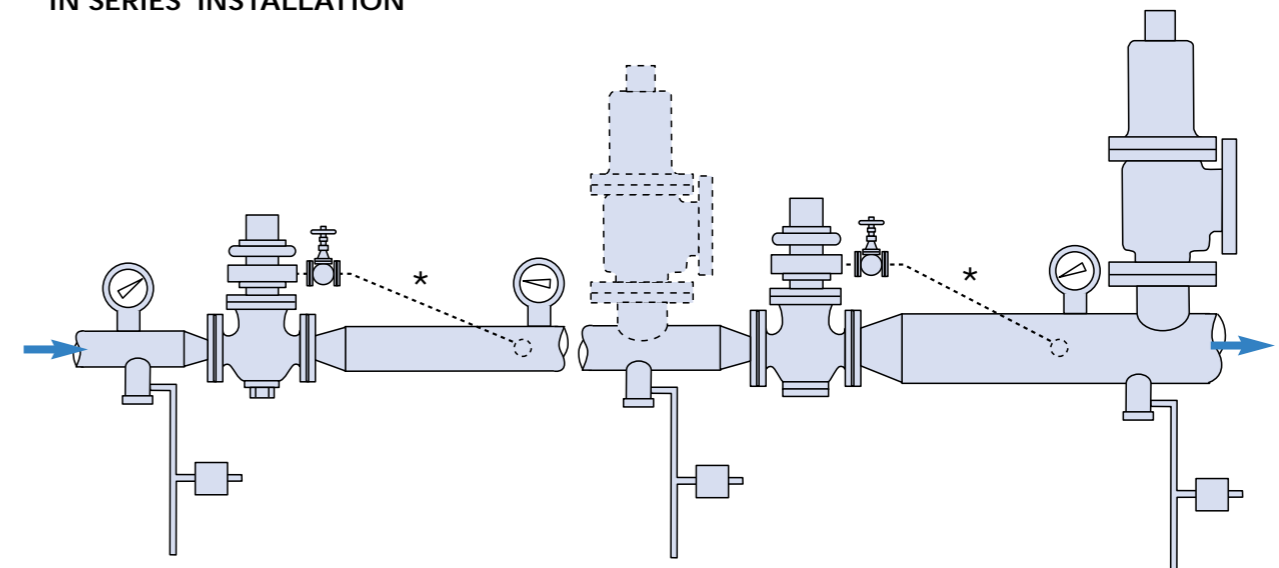

### 'IN PARALLEL' INSTALLATION

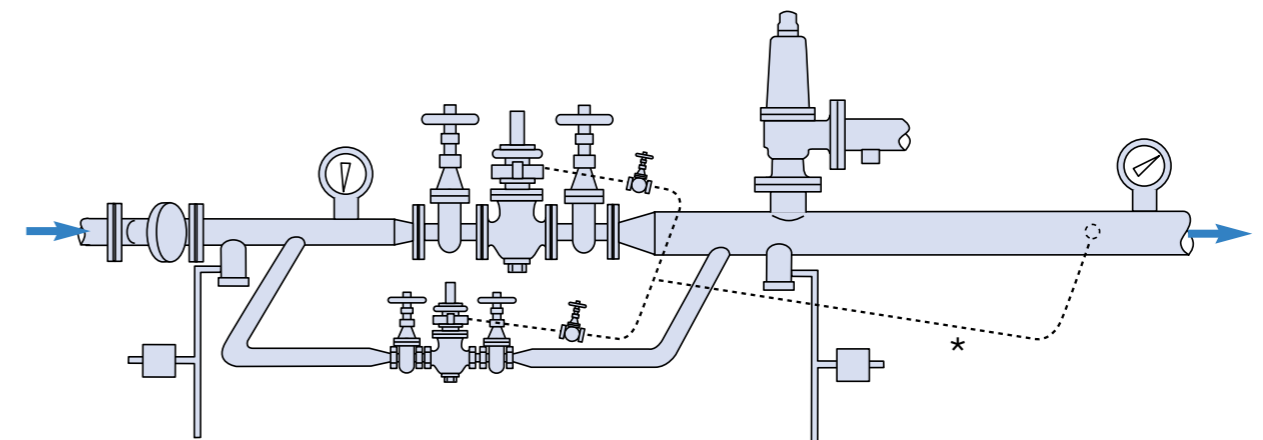

\*Balance lines are only required on some steam applications, they are not required on air/gas applications.

## 'IN PARALLEL' INSTALLATIONS

Multiple valves can be installed as an 'in parallel' system when the system has a very large variation in the required capacity. On such a system one large and one small valve should be installed, with a combined capacity greater than the maximum required demand, the smaller valve having a capacity just greater than the minimum required demand.

Setting the smaller valve slightly higher than the larger valve, will ensure that the larger valve is closed at low flow rates. Increasing demand will then open the larger valve as outlet pressure falls to its set point.

A typical diagram is shown (using close coupled parallel slide isolating valves).

## INSTALLATION

### TYPICAL STEAM REDUCING VALVE INSTALLATION USING GLOBE STOP VALVES

\*(Note: if you use parallel slide stop valves, they can be close coupled to the G4.)

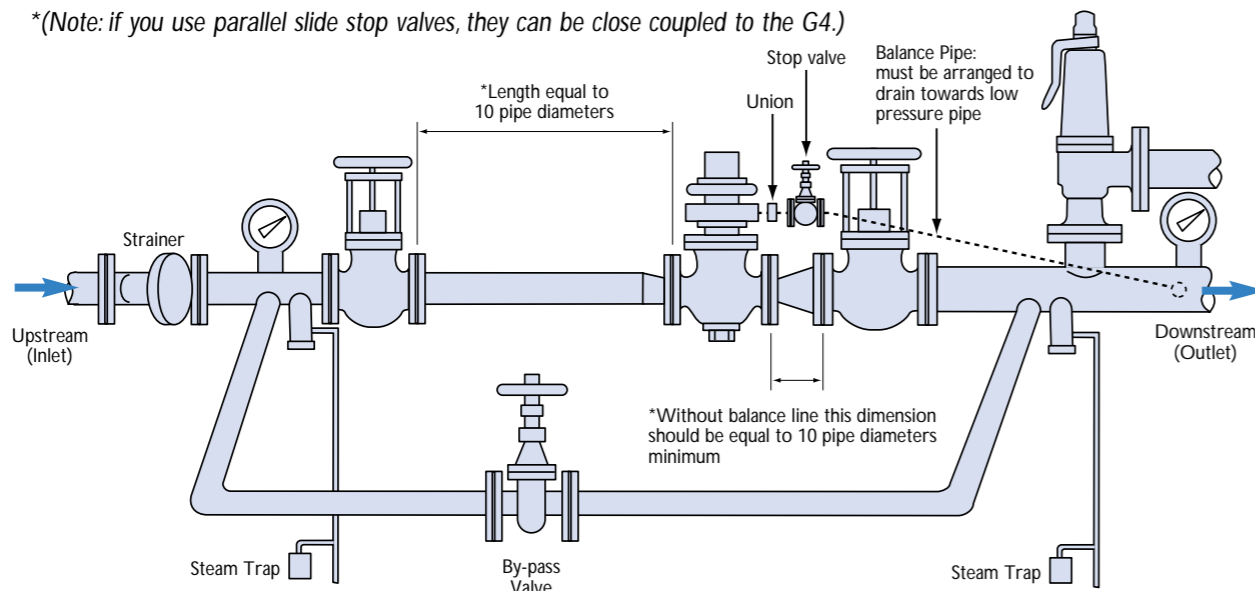

The majority of troubles experienced with pressure regulators can be attributed to installation faults. These can be avoided by giving attention to the following points:

#### Sizing

The correct sizing and layout of regulators, pipework, stop valves, strainers and other fittings is extremely important for good performance.

#### Inlet Strainer

Dirt, grit and pipe scale are common causes of regulator failure. A strainer of upstream pipe size should be fitted at least 10 pipe diameters before the regulator.

#### Steam Traps

Steam reducing valve stations should have steam traps fitted on the inlet and outlet pipes, to prevent build up of condensate in the regulator, particularly under no flow conditions.

#### Safety Valve

Every installation should be fully protected against regulator failure by a safety valve. Care should be taken that the discharge from such a valve cannot cause damage to property or create a hazard to personnel. The safety valve should be sized to pass the maximum capacity of the regulator.

#### Pipe work

All pipework and fittings should be properly supported and free from any strain or vibrations which could affect their correct operation. All flanges should be correctly aligned and joints carefully fitted to avoid blockage of valve ports.

If a jointing compound is used it should not be allowed to foul the internal ports or working parts of the valve.

#### Balance Pipe (Steam applications only)

A balance pipe should be fitted when the reduced pressure is 55% or less of the inlet pressure, or to help counteract difficult turbulent downstream conditions caused by pipe fittings, valves or bends. The method of connecting the balance pipe to the reducing valve is shown in the sketch. It should drain downwards and be connected into the side of the downstream pipe at a point where smooth flow occurs, (preferably downstream of the safety valve). Where isolation of the regulator is desired, a stop valve should be fitted in the balance line.

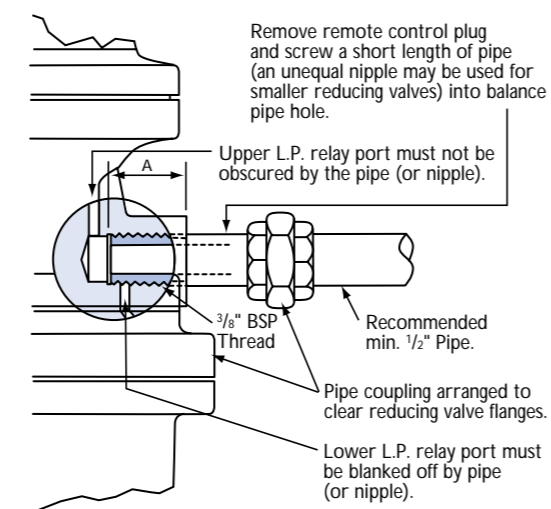

'A' dimension must be  $1\frac{5}{16} \pm 1/16$ " on all stainless steel valves or CS Fig 2046. All other valves with bronze pilot tops, the pipe should penetrate 1" minimum.

### Before putting a regulator into service

Prior to installing the valve all pipes should be thoroughly blown-through to remove any dirt, grit or pipe scale. Additional cleaning can be done by removing the regulator bottom plug, main valve and spring, and then carefully opening the inlet stop valve by a small amount. Remove any dirt lodged in valve body and replace parts.

## SETTING

### Setting under no flow conditions

This is the more accurate method and may be carried out as follows:

1. Any condensate remaining in the pipeline should be removed by first applying a little tension to the regulator adjusting spring (by rotating the adjusting screw clockwise for a few turns) and then slowly opening the outlet and inlet stop valves. When the downstream pressure starts to rise, close the inlet stop valve and remove all tension from the regulator adjusting spring.
2. Close the outlet stop valve and slowly open the inlet stop valve. Wait for about one minute to confirm that the reduced pressure is maintained at zero. This is a check that the regulator gives 'dead-tight' shut-off under no flow conditions.
3. Slowly raise the reduced pressure (by rotating the regulator adjusting screw clockwise) until the desired pressure is obtained. (Do not forget to set the safety valve 15% above the reduced pressure, if necessary.) The valve is now correctly set and the adjusting screw should be locked with the lock-nut provided.
4. Slowly bring the outlet stop valve to 'full open' and apart from a possible initial 'fall back' of the reduced pressure (whilst the systems is warmed through) the regulator should continue to maintain the reduced pressure.

### Setting On Flow

With the inlet and outlet stop valves closed, apply a little tension to the regulator adjusting spring (by rotating the adjusting screw clockwise for a few turns). Open the inlet and all downstream stop valves and then wait until all condensate has been removed and the system properly warmed

through. Then slowly raise the reduced pressure by clockwise rotation of the adjusting screw until the desired reduced pressure is obtained. (Do not forget to set the Safety Valve, if necessary.) If the flow is varying, some trial and error may be necessary before the correct setting is finally achieved. The reduced pressure under no-flow conditions should be checked as soon as convenient.

We strongly recommend that the inlet strainer and reducing valve should be cleaned out one week after commissioning, and the strainer and steam traps checked at regular intervals thereafter.

### Outlet Pressure Regulation

Up to 80mm (3") size  $\pm 1/2\%$  of outlet pressure  
[ $\pm 0.035$  Barg ( $1/2$  Psig) below 6.9 Barg (100 Psig)]

Above 80mm (3") size  $\pm 1\%$  of outlet pressure  
[ $\pm 0.07$  Barg (1 Psig) below 6.9 Barg (100 Psig)]

Pressure rise at dead end (steam only) = 1%.

## SPRING SELECTION

If possible it is advisable to select a spring which has at least 10% additional adjustment above the required set pressure. As can be seen from the chart, the springs have overlapping ranges. Where possible the spring with the lowest range should be selected.

### 15-100mm (1/2" - 4") VALVES

Barg	(Psig)	Colour Code
0.07-3.5	(1-50)	Yellow
0.7-7.0	(10-100)	Black
2.8-10.5	(40-150)	White
3.5-14.0	(50-200)	Green
7.0-21.0	(100-300)	Red

### 125-150mm (5"-6") VALVES

Barg	(Psig)	Colour Code
0.35-1.4	(5-20)	Red
0.7-3.5	(10-50)	Yellow
2.8-7.0	(40-100)	Black
3.5-12.0	(50-175)	Green

## SIZING

The G4 Pressure Regulator can give its best performance when correctly sized to match the maximum demand of the system. It is therefore important that the size of regulator is decided from the known or estimated consumption and never fitted just as a line size valve. It is useful to remember that the G4 is a full lift, high capacity valve and correctly sized will almost invariably be smaller than the size of the pipe work.

The valve sizing charts illustrate that the maximum capacity occurs when the outlet pressure is less than 55% of the inlet pressure (critical pressure drop sizing). When the outlet pressure is above 55% sub critical flow occurs and the capacity will be reduced. De-rating factors are given on the sizing charts. Critical pressure drop sizing is only true when both the inlet and outlet pipework is sized correctly in accordance with our pipe sizing charts.

It is important to remember that the outlet pipe is invariably larger than the inlet pipe, in order to pass the same quantity of steam, air or gas at a lower pressure.

**Note** Undersized pipe work and fittings cause unnecessary and uncontrolled pressure losses and are a major cause of unstable control.

### Capacity Variations

The sizing charts give the maximum capacities which can be handled by the regulator for the given inlet and outlet pressures.

For trouble free operation the minimum flow rate should be considered to be 10% of the maximum.

### Steam

If no steam capacity is given, size the regulator based on the maximum flow which can be achieved through the inlet pipe, according to our pipe sizing charts.

Alternatively, if the maximum heat requirement of the system is known, the following approximate relationship can be used.

Steam Capacity:

$$\text{Kg/h} = \text{Kcals} \div 554$$

$$\text{kg/h} = \text{kW} \times 0.6446$$

$$\text{lbs/h} = \text{B.T.U's/h} \div 1000$$

### Superheated Steam

If the steam temperature is greater than the saturated steam temperature, the capacities shown in our tables will need to be reduced.

DEGREES OF SUPERHEAT		
°C	°F	Factor
0 to 10	0 to 50	multiply by 0.96
10 to 50	50 to 100	multiply by 0.92
50 to 75	100 to 150	multiply by 0.89
75 to 100	150 to 200	multiply by 0.86
100 to 150	200 to 300	multiply by 0.82

### Air and Gases

For gases other than air, divide the chart air capacity by  $\sqrt{\text{SG}}$  (SG of Air = 1) to give the equivalent gas capacity.

### Other Temperatures

The air/gas capacity tables are based on air at 15°C. If the actual flowing temperature is different, the chart capacity will need to be divided by  $\sqrt{(T/288)}$

Where: T= flowing temperature °C + 273°k.

## SIZING EXAMPLES

### EXAMPLE 1

#### Requirement

Fluid - Steam @ 184°C

Inlet Pressure - 10 Barg

Outlet Pressure - 7 Barg

Required Capacity - 1100 kg/h

#### Sizing

Refer to the sizing chart on page 15. At an inlet pressure of 10 Barg it can be seen that the chart capacity must be derated when the outlet pressure is above 5.5 Barg, which is the case in this example.

7 Barg ÷ 10 Barg gives a pressure ratio of 0.7. The equivalent sub-critical flow de-rating factor for all sizes is 0.88.

The first valve to pass more than 1100 kg/h is the 32mm (1¼"), which will pass  $1489 \times 0.88 = 1310$  kg/h at the required pressures.

While still looking at the chart, it is important to check that the required outlet pressure is within the available pressure range for the valve selected. In this example the available setting range is 0.35 to 9.3 Barg, our required pressure is within this range.

#### Selection

Refer to page 2 and page 19.

We can choose between figures 2042, 2043 or 2046. The choice will then depend on the customer's requirements on connections and materials. The most economical choice would be the 2042 screwed bronze valve.

At 7 Barg a standard top is acceptable (ref. page 4), only one diaphragm is required (ref. page 8) and the white spring (ref. page 10) should be fitted with a range of 2.8 to 10.5 Barg.

#### Inlet Pipe Size

Refer to page 17, at 10 Barg the smallest pipe to pass our required flow of 1100kg/h is 50mm (2").

#### Outlet Pipe Size

Refer to page 17, at 7 Barg the smallest pipe to pass our required flow of 1100kg/h is 65mm (2 ½").

### EXAMPLE 2

#### Requirement

Fluid - Air @ ambient temperature 60°F

Inlet pressure - 100 Psig

Outlet pressure - 3 Psig

Required capacity - 150 SCFM

#### Sizing

Refer to the sizing chart on page 16. At an inlet pressure of 100 Psig it can be seen that the chart capacity can be used as our outlet pressure is below 55 Psig. It can also be seen that our required set pressure of 3 Psig is within the available setting range of 1 to 90 Psig for a 20mm (¾") valve. This is the smallest size to pass more than our required capacity of 150 SCFM, it will actually pass 294 SCFM. However, as can be seen from the \*note on the chart page, a low pressure top is required.

#### Selection

Refer to page 2 and page 19.

We can choose between figures 2042GN, 2043GN, and 2046GN.

These are minimum recommendations, others can be used if the materials are suitable.

The actual choice will depend on the customers requirements on connections and materials. The most economical would be the 2042 screwed bronze valve fitted with a low pressure top.

For 3 Psig the yellow spring (ref. page 10) should be used with a range of 1 to 50 Psig.

#### Inlet Pipe Size

Refer to page 17 at 100 Psig (approx 7 Barg).

To read the chart we need an equivalent steam capacity.

∴ 150 SCFM air ÷ .66 gives approx 227kg/h steam  
∴ 32mm (1¼") pipe.

#### Outlet Pipe Size

Refer to page 17 at 3 Psig (nearest 0.5 Barg)

∴ 150 SCFM air ÷ .66 gives approx 227kg/h steam  
∴ 65mm (2½") pipe.

## SURPLUS/MAINTAINING VALVE

The 'G4 surplus' valve can also be described as a 'pressure maintaining' or 'pressure sustaining' valve.

In these days of high energy costs and environment emission controls, steam and air systems can be very expensive to install and run. Often most industrial applications need steam or air for the main process plant and it is critical to maintain the supply to these processes. Additionally, such plants will also have other demands of a less critical nature such as compressed air lines, heating and cleaning systems.

Obviously two separate systems could be employed, providing that the necessary funds are available to install and run both. Alternatively the secondary and less critical applications can be run from the surplus generated from the main system. However, during periods of extreme demand the main process could be starved of steam or air, resulting in production disruption and product loss. (See figure 1).

**The solution is to fit a 'G4 surplus' valve.**

The 'G4 surplus' valve is designed to be installed in branch lines to non-essential equipment (see figure 1), to maintain the upstream pressure, thus maintaining the supply to the more vital process and subsequently maintaining production from the system. Alternatively to dump flow surplus to requirements, to a drain or atmosphere.

Additionally if the pressure in a boiler or air accumulator is allowed to fall too low, a lot of energy will be required to build up the pressure once again (see figure 2).

**The solution is to fit a 'G4 Maintaining' valve.**

The 'G4 Maintaining' valve is designed to be installed in the main pipeline from the boiler or an air compressor (see figure 2), to maintain the pressure in the boiler or accumulator, thus preventing the boiler or accumulator from becoming exhausted.

### Operation

The inlet pressure is directed under the diaphragm. A small increase in pressure above the set pressure lifts the diaphragm and opens the pilot valve, which in turn opens the main valve. Subsequently when excess demand drops the pressure below the required level, the adjusting spring will overcome the pressure under the diaphragm and close the pilot valve. This in turn causes the main valve to close, thus cutting the surplus supply and/or maintaining pressure in the main line, boiler or accumulator.

This duty and valve type is known by many names. As can be seen in this text the valve 'maintains' or 'sustains' pressure in the main line, boiler or accumulator and can use 'surplus' pressure for non-essential services.

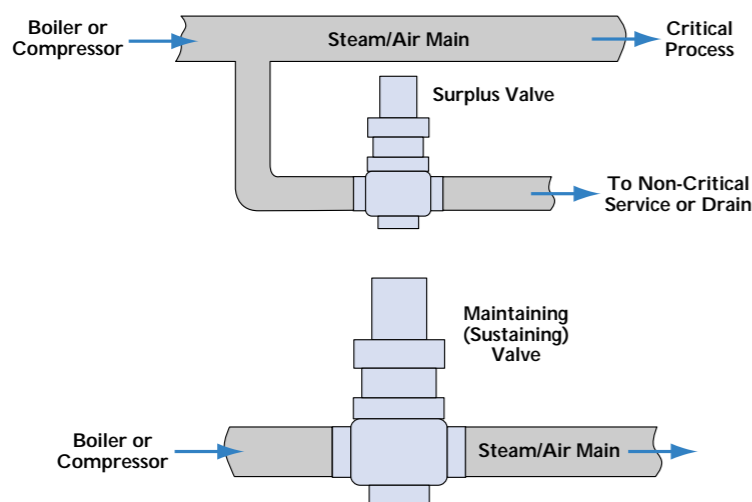
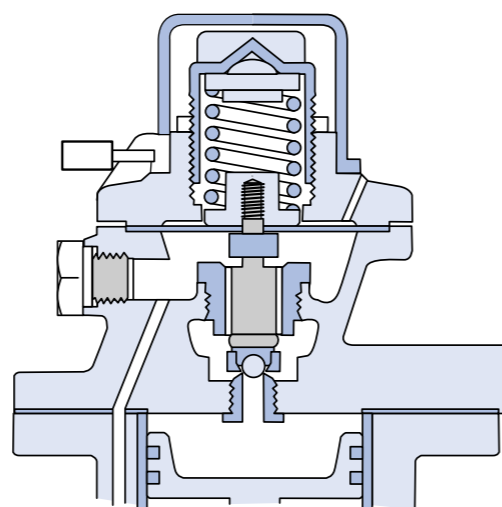

**Figure 1**  
When the G4 surplus valve is closed, the full flow from boiler/compressor goes to the critical process.

**Figure 2**  
When the G4 maintaining valve is closed, the full flow from boiler/compressor is stopped and the minimum pressure of the boiler/accumulator is maintained.

## SURPLUS MAINTAINING VALVE SELECTION

### Example 1: Surplus duty (see figure 1)

A steam boiler normally working at a pressure of 10 Barg, delivers steam to a critical process which must not fall below 8 Barg (closing pressure) in order to preserve correct operation. The excess (surplus) capacity produced can be used for a non-critical service. If this non-critical service requires 3500 Kg/h of saturated steam, what size of G4 surplus valve will be required?

A surplus valve is normally sized on the minimum allowable pressure drop across the valve ie: at an equivalent pressure equal to the maximum outlet setting of the valve. Looking at page 15 and the 10 Barg inlet pressure, the maximum outlet setting is 9 barg for 2½" to 4" valves. This gives a pressure ratio of (%) 0.9, hence a derating factor of 0.48. To read

the chart, divide the required flow of 3500kg/h by 0.48 to give an equivalent chart flow of 7292kg/h. It can be seen that the 80mm (3") valve will pass a maximum flow of 7398kg/h which is derated to an actual flow of 3551kg/h (ie 7398 x 0.48).

### Example 2: Pressure maintaining duty (see figure 2).

A steam boiler, normally working at a pressure of 10 Barg, delivers steam to a process. It is determined that the boiler pressure must not fall below 8 Barg. The process normally requires 3500 Kg/h of saturated steam, what size of G4 maintaining valve will be required?

Selecting a pressure maintaining valve is the same as selecting a surplus valve, therefore follow the same sizing procedure.

## VALVE PERFORMANCE

A small pressure rise (accumulation) above the set point is required to fully open the valve, and a small pressure drop (regulation) below the set pressure is required to close the valve. It is therefore important to set the valve higher than the pressure at which the valve must be closed, to allow for this regulation.

In the above examples the valve must be set at a minimum of 8.15 Barg. This allows for the regulation of 0.15 Barg to ensure the valve is fully closed at 8 Barg. It can also be seen that the valve will be fully open by 8.35 Barg (i.e. 0.2 Barg accumulation above the set point of 8.15 Barg).

### Spring selection

If possible, it is advisable to select a spring which has at least 10% adjustment above the required set pressure. As can be seen from the chart, the springs have overlapping ranges and therefore, where possible, the spring with the lowest pressure range should be selected.

In the examples we require a spring for a pressure of 8.1 Barg (ideally plus 10%, say 9 Barg). As can be seen the white, green and red springs can do this pressure, however the white spring should be selected as it has the lower range.

### Valve selection

Referring to the charts on page 2 and page 20, it can be seen that the figures 2044 and 2045 are suitable for the given conditions.

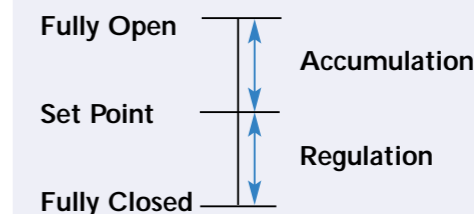

Closing Pressure	Accumulation	Regulation
Barg	(Psig)	Barg (Psig)
0.35 - 3.5	(5 - 50)	0.10 (1.5)
3.5 - 7.0	(50 - 100)	0.10 (1.5)
7.0 - 10.3	(100 - 150)	0.20 (3.0)
10.3 - 20.7	(150 - 300)	0.50 (7.0)

Spring Colour Code	Spring Pressure Range	
	Barg	(Psig)
Yellow	0.35 - 3.5	(5 - 50)
Black	0.7 - 7.0	(10 - 100)
White	2.8 - 10.3	(40 - 150)
Green	3.5 - 14.0	(50 - 200)
Red	7.0 - 20.7	(100 - 300)

## DIAPHRAGMS

For pressures above 10.3 Barg (150 Psig) two diaphragms must be fitted. Below this pressure only one diaphragm is fitted.



# Piping Capacities

**CAPACITIES FOR STEAM IN kg/h – READ DIRECTLY FROM CHART.** (For lbs/h multiply capacity by 2.2046.)

Estimated Air capacities – multiply chart capacities as follows:

- (1) Multiply chart capacity by 0.66 to give Air flow in SCFM
- (2) Multiply chart capacity by 1.2 to give Air flow in Nm<sup>3</sup>/h

Estimated Air pressure drops:

For guidance multiply the chart pressure drop by 1.23 to give an approximate Air pressure drop.

Pressure in Psig	Pressure in Barg	PIPE SIZE (millimetres)														
		15	20	25	32	40	50	65	80	100	125	150	200	250	300	350
7.5	0.5	9 <i>0.03</i>	18 <i>0.03</i>	30 <i>0.03</i>	45 <i>0.03</i>	88 <i>0.03</i>	159 <i>0.03</i>	308 <i>0.03</i>	476 <i>0.03</i>	705 <i>0.03</i>	1270 <i>0.03</i>	1540 <i>0.03</i>	3080 <i>0.02</i>	4620 <i>0.02</i>	6810 <i>0.02</i>	9430 <i>0.02</i>
15	1.0	12 <i>0.04</i>	22 <i>0.04</i>	39 <i>0.04</i>	59 <i>0.04</i>	118 <i>0.04</i>	218 <i>0.04</i>	400 <i>0.04</i>	590 <i>0.04</i>	975 <i>0.04</i>	1630 <i>0.04</i>	2270 <i>0.04</i>	4000 <i>0.03</i>	6430 <i>0.03</i>	9480 <i>0.03</i>	13100 <i>0.03</i>
30	2.0	16 <i>0.05</i>	33 <i>0.06</i>	55 <i>0.06</i>	88 <i>0.06</i>	177 <i>0.06</i>	305 <i>0.06</i>	545 <i>0.06</i>	840 <i>0.06</i>	1475 <i>0.06</i>	2450 <i>0.06</i>	3500 <i>0.06</i>	6140 <i>0.05</i>	8920 <i>0.04</i>	13100 <i>0.04</i>	18200 <i>0.04</i>
45	3.0	20 <i>0.07</i>	44 <i>0.08</i>	75 <i>0.08</i>	118 <i>0.09</i>	241 <i>0.10</i>	419 <i>0.10</i>	795 <i>0.09</i>	1180 <i>0.08</i>	1900 <i>0.08</i>	3080 <i>0.08</i>	4400 <i>0.08</i>	8160 <i>0.07</i>	12400 <i>0.06</i>	16700 <i>0.05</i>	23200 <i>0.05</i>
60	4.0	24 <i>0.10</i>	54 <i>0.10</i>	97 <i>0.11</i>	147 <i>0.12</i>	309 <i>0.13</i>	545 <i>0.12</i>	1040 <i>0.12</i>	1500 <i>0.12</i>	2450 <i>0.11</i>	4080 <i>0.11</i>	5670 <i>0.11</i>	10200 <i>0.10</i>	16900 <i>0.09</i>	23500 <i>0.08</i>	30400 <i>0.07</i>
75	5.0	29 <i>0.11</i>	67 <i>0.12</i>	116 <i>0.13</i>	180 <i>0.14</i>	359 <i>0.14</i>	625 <i>0.14</i>	1180 <i>0.14</i>	1820 <i>0.14</i>	2950 <i>0.13</i>	4760 <i>0.13</i>	6670 <i>0.13</i>	13100 <i>0.12</i>	20300 <i>0.11</i>	28600 <i>0.10</i>	37500 <i>0.09</i>
90	6.0	36 <i>0.12</i>	76 <i>0.14</i>	136 <i>0.15</i>	211 <i>0.16</i>	427 <i>0.16</i>	750 <i>0.16</i>	1400 <i>0.16</i>	2130 <i>0.16</i>	3450 <i>0.16</i>	5800 <i>0.16</i>	7950 <i>0.15</i>	15000 <i>0.14</i>	23700 <i>0.13</i>	33600 <i>0.12</i>	44500 <i>0.11</i>
100	7.0	43 <i>0.14</i>	91 <i>0.16</i>	154 <i>0.18</i>	245 <i>0.18</i>	490 <i>0.19</i>	864 <i>0.19</i>	1650 <i>0.19</i>	2450 <i>0.18</i>	3950 <i>0.18</i>	6600 <i>0.18</i>	9300 <i>0.17</i>	17200 <i>0.16</i>	27100 <i>0.15</i>	38600 <i>0.14</i>	51500 <i>0.13</i>
115	8.0	48 <i>0.15</i>	104 <i>0.17</i>	182 <i>0.20</i>	272 <i>0.21</i>	545 <i>0.22</i>	955 <i>0.22</i>	1860 <i>0.22</i>	2640 <i>0.20</i>	4300 <i>0.20</i>	7270 <i>0.20</i>	10200 <i>0.19</i>	19000 <i>0.18</i>	30500 <i>0.17</i>	43700 <i>0.16</i>	58500 <i>0.15</i>
130	9.0	52 <i>0.18</i>	113 <i>0.20</i>	200 <i>0.24</i>	309 <i>0.25</i>	613 <i>0.26</i>	1140 <i>0.26</i>	2180 <i>0.26</i>	3090 <i>0.25</i>	5080 <i>0.25</i>	8650 <i>0.25</i>	12200 <i>0.23</i>	21800 <i>0.22</i>	34800 <i>0.20</i>	50000 <i>0.19</i>	65500 <i>0.17</i>
145	10.0	57 <i>0.20</i>	123 <i>0.23</i>	222 <i>0.27</i>	336 <i>0.30</i>	668 <i>0.30</i>	1200 <i>0.30</i>	2360 <i>0.29</i>	3400 <i>0.28</i>	5580 <i>0.28</i>	9550 <i>0.28</i>	13400 <i>0.27</i>	25000 <i>0.26</i>	39900 <i>0.24</i>	57500 <i>0.23</i>	76100 <i>0.21</i>
175	12.0	67 <i>0.23</i>	136 <i>0.27</i>	259 <i>0.31</i>	418 <i>0.34</i>	818 <i>0.35</i>	1450 <i>0.35</i>	2900 <i>0.37</i>	4090 <i>0.36</i>	6850 <i>0.35</i>	11500 <i>0.35</i>	16100 <i>0.34</i>	30000 <i>0.31</i>	47500 <i>0.29</i>	68700 <i>0.28</i>	91700 <i>0.26</i>

Pressure in Psig	Pressure in Barg	PIPE SIZE (millimetres)														
		15	20	25	32	40	50	65	80	100	125	150	200	250	300	350
220	15.0	75 <i>0.29</i>	168 <i>0.33</i>	318 <i>0.39</i>	510 <i>0.42</i>	1020 <i>0.44</i>	1820 <i>0.45</i>	3640 <i>0.46</i>	5220 <i>0.46</i>	8600 <i>0.46</i>	14300 <i>0.46</i>	19700 <i>0.43</i>	33200 <i>0.41</i>	59000 <i>0.39</i>	84600 <i>0.37</i>	113900 <i>0.35</i>
260	18.0	93 <i>0.35</i>	227 <i>0.40</i>	395 <i>0.46</i>	617 <i>0.49</i>	1230 <i>0.51</i>	2270 <i>0.52</i>	4300 <i>0.54</i>	6450 <i>0.55</i>	10900 <i>0.55</i>	17700 <i>0.55</i>	24500 <i>0.53</i>	47600 <i>0.51</i>	74100 <i>0.49</i>	106900 <i>0.47</i>	144800 <i>0.45</i>
290	20.0	107 <i>0.38</i>	250 <i>0.44</i>	435 <i>0.50</i>	680 <i>0.55</i>	1360 <i>0.57</i>	2460 <i>0.59</i>	4760 <i>0.62</i>	7030 <i>0.64</i>	12200 <i>0.64</i>	20000 <i>0.64</i>	28200 <i>0.63</i>	54000 <i>0.61</i>	85400 <i>0.59</i>	123600 <i>0.57</i>	168100 <i>0.55</i>
360	25.0	134 <i>0.47</i>	287 <i>0.54</i>	522 <i>0.61</i>	838 <i>0.66</i>	1680 <i>0.68</i>	2890 <i>0.71</i>	5400 <i>0.74</i>	8790 <i>0.76</i>	14700 <i>0.78</i>	24200 <i>0.78</i>	36100 <i>0.78</i>	66600 <i>0.76</i>	106000 <i>0.74</i>	154000 <i>0.72</i>	210000 <i>0.70</i>
435	30.0	159 <i>0.56</i>	342 <i>0.64</i>	619 <i>0.72</i>	995 <i>0.78</i>	2010 <i>0.82</i>	3450 <i>0.85</i>	6470 <i>0.89</i>	10500 <i>0.91</i>	17600 <i>0.93</i>	28900 <i>0.93</i>	43100 <i>0.93</i>	79600 <i>0.91</i>	127100 <i>0.89</i>	185000 <i>0.87</i>	253400 <i>0.85</i>
510	35.0	186 <i>0.66</i>	399 <i>0.75</i>	721 <i>0.84</i>	1170 <i>0.92</i>	2370 <i>0.98</i>	4060 <i>1.01</i>	7550 <i>1.04</i>	12200 <i>1.06</i>	20400 <i>1.08</i>	33500 <i>1.08</i>	50100 <i>1.08</i>	92700 <i>1.06</i>	148200 <i>1.04</i>	216200 <i>1.02</i>	296400 <i>1.00</i>
580	40.0	214 <i>0.76</i>	456 <i>0.86</i>	820 <i>0.95</i>	1320 <i>1.03</i>	2690 <i>1.10</i>	4610 <i>1.14</i>	8550 <i>1.17</i>	13900 <i>1.20</i>	23300 <i>1.23</i>	38200 <i>1.23</i>	57100 <i>1.23</i>	105800 <i>1.21</i>	169400 <i>1.19</i>	247500 <i>1.17</i>	339700 <i>1.15</i>
610	42.0	221 <i>0.79</i>	420 <i>0.89</i>	847 <i>0.99</i>	1360 <i>1.07</i>	2770 <i>1.14</i>	4750 <i>1.18</i>	11900 <i>2.20</i>	14400 <i>1.26</i>	24100 <i>1.29</i>	39700 <i>1.29</i>	59200 <i>1.29</i>	109800 <i>1.27</i>	175800 <i>1.25</i>	256900 <i>1.23</i>	352800 <i>1.21</i>

**Note (1)** Figures in *blue italics* show pressure drops (Barg) for equivalent lengths equal to 360 pipe diameters. When using this table, allowance should be made for the effects of bends and fittings in the pipe line.

**Note (2)** All capacity values are based on acceptable pressure drops, not velocity per unit length of pipe. Higher pressure drops will result in higher steam velocities and increased noise levels.

**Example**

**Question:** What size pipe will pass 800 kg/h of dry saturated steam at 7 Barg?

50mm pipe will pass 864 kg/h at 7 Barg (Pressure drop over 18m (360 pipe diameters) will be approximately 0.19 Barg).

# Piping Capacities

TECHNICAL SPECIFICATION - G4 REDUCING VALVES

Figure Number	Size Range mm	Connections	MATERIALS			PRESSURE Barg		TEMP.
			Body	Pilot Top	Main Valve Trim	Inlet Min-Max	Outlet Min-Max	Deg.C Min-Max
2042	15-50	Screwed	Bronze	Bronze	St Steel	0.7-35§	0.07-21	-20 to +260
†2042GN	15-50	Screwed	Bronze	Bronze	Nitrile	0.7-31	0.07-21	-20 to +100
†2042GV	15-50	Screwed	Bronze	Bronze	Viton	0.7-31	0.07-21	-18 to +150
†2042GP	15-50	Screwed	Bronze	Bronze	PTFE	0.7-35	0.07-21	-20 to +170
2042SS	15-50	Screwed	St Steel	St Steel	St Steel	0.7-42	0.35-21‡	-20 to +260
2042SN	15-50	Screwed	St Steel	St Steel	Nitrile	0.7-42	0.35-21‡	-20 to +100
2042SP	15-50	Screwed	St Steel	St Steel	PTFE	0.7-42	0.35-21‡	-20 to +170
2043	15-50	Flanged	Bronze	Bronze	St Steel	0.7-35§	0.07-21	-20 to +260
†2043GN	15-50	Flanged	Bronze	Bronze	Nitrile	0.7-31	0.07-21	-20 to +100
†2043GV	15-50	Flanged	Bronze	Bronze	Viton	0.7-31	0.07-21	-18 to +150
†2043GP	15-50	Flanged	Bronze	Bronze	PTFE	0.7-35	0.07-21	-20 to +170
2043SS	15-50	Flanged	St Steel	St Steel	St Steel	0.7-42	0.35-21‡	-20 to +260
2043SN	15-50	Flanged	St Steel	St Steel	Nitrile	0.7-42	0.35-21‡	-20 to +100
2043SP	15-50	Flanged	St Steel	St Steel	PTFE	0.7-42	0.35-21‡	-20 to +170
2044	65-150	Flanged	Cast Iron	Bronze	St Steel	0.7-16π§	0.07-15π§	-20 to +220
†2044GP	65-150	Flanged	Cast Iron	Bronze	PTFE	1.0-16	0.07-15π	-20 to +170
2045	65-150	Flanged	Carbon St.	Bronze	St Steel	0.7-35π§	0.35-21π§	-20 to +260
†2045GP	65-150	Flanged	Carbon St.	Bronze	PTFE	1.0-35	0.07-21§	-20 to +170
2046	15-150	Flanged	Carbon St.	Carbon St.	St Steel	0.7-42π§	0.35-21π§	-20 to +400
†#2046GN	15-50	Flanged	Carbon St.	Carbon St.	Nitrile	0.7-31	0.35-21	-20 to +100
†#2046GV	15-50	Flanged	Carbon St.	Carbon St.	Viton	0.7-31	0.35-21	-18 to +150
†#2046GP	15-150	Flanged	Carbon St.	Carbon St.	PTFE	1.0-42	0.35-21π	-20 to +170

The pressures and temperatures in this table are the maximum for the model shown, restrictions apply as shown below.

Note: When outlet pressure is less than 0.35 Barg a low pressure top will be fitted.

† 'G' for gas duty can be replaced by 'O' for oxygen duty.

‡ When a stainless steel spring is fitted the maximum outlet pressure is 10.5 Barg.

# 15/20/25mm are all fitted into the 25mm body (1" flanges).

32/40/50mm are all fitted into the 50mm body (2" flanges).

§ - Steam Service Restrictions

Figure Number	Restriction on:	Restriction
2042	Inlet	25 Barg to 225°C/17 Barg to 260°C
2043	Inlet	25 Barg to 225°C/17 Barg to 260°C
2044	Inlet	13 Barg Max
2044	Outlet	12 Barg Max
2045	Inlet	65-150mm 25 Barg to 225°C/17 Barg to 260°C
2045	Outlet	65-100mm 21 Barg to 225°C/16 Barg to 260°C
2045	Outlet	125-150mm 12 Barg Max
2046	Inlet	42 Barg to 280°C/32 Barg to 400°C
2046	Outlet	125-150mm 12 Barg Max

π - Air Service Restrictions

Figure Number	Restriction on:	Restriction
2044	Inlet	16 Barg to 120°C/13 Barg to 220°C
2044	Outlet	65-100mm 15 Barg to 120°C/12 Barg to 220°C
2044	Outlet	125-150mm 12 Barg
2045	Inlet	65-150mm 35 Barg to 170°C/17 Barg to 260°C
2045	Outlet	65-100mm 21 Barg to 170°C/16 Barg to 260°C
2045	Outlet	125-150mm 12 Barg Max
2046	Inlet	42 Barg to 280°C/32 Barg to 400°C
2046	Outlet	125-150mm 12 Barg

TECHNICAL SPECIFICATION-G4 SURPLUS/MAINTAINING VALVES

Figure No.	2042	2043	2044	2045
Size	15 – 50mm (1/2 – 2ins)	15 – 50mm (1/2 – 2ins)	65 – 100mm (2 1/2 – 4ins)	65 – 100mm (2 1/2 – 4ins)
Connections	Screwed	Flanged	Flanged	Flanged
Material	Bronze	Bronze	Cast Iron	Cast Steel
Max. inlet pressure	20.7 Barg (300 Psig)	20.7 Barg (300 Psig)	20.7 Barg (300 Psig)	20.7 Barg (300 Psig)
Min. inlet pressure	0.7 Barg (10 Psig)	0.7 Barg (10 Psig)	1.03 Barg (15 Psig)	1.03 Barg (15 Psig)
Temperature range	Min.	Max.	Max.	Max.
Stainless steel seat	-20°C (-68°F)	260°C (500°F)	260°C (500°F)	220°C (430°F)
Nitrile seat	-20°C (-68°F)	100°C (212°F)	100°C (212°F)	100°C (212°F)
Viton seat	-18°C (-64°F)	150°C (302°F)	150°C (302°F)	150°C (302°F)
PTFE seat	-20°C (-68°F)	170°C (338°F)	170°C (338°F)	170°C (338°F)

## DIMENSIONS

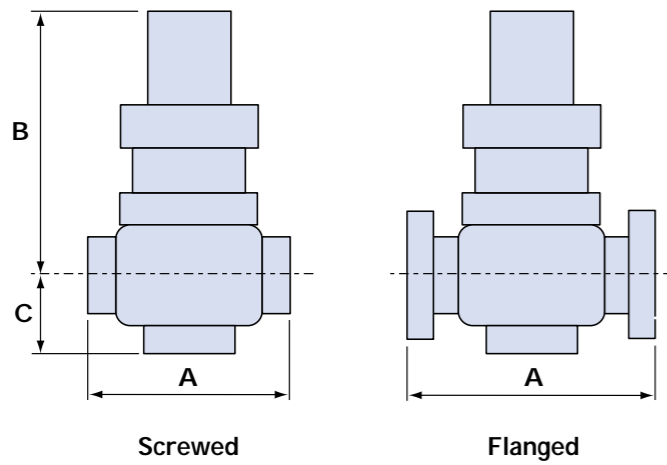

## CONNECTION OPTIONS

**Screwed**  
BSP\*\* API/NPT

**Flanged**  
BS4504 PN\*\* ANSI, BS10

\*\*Standard item.

Valve type	Size	Connection	A		DIN flange mm	B		C		Weight kg
			ins	mm		ins	mm	ins	mm	
Fig 2042 Screwed Bronze or Stainless Steel	15mm	1/2" BSP	4.125	105	-	8	203	2.375	60	6
	20mm	3/4" BSP	4.125	105	-	8.25	210	2.5	64	6.8
	25mm	1" BSP	4.5	114	-	8.375	213	2.625	67	7
	32mm	1 1/4" BSP	4.875	124	-	9.625	244	3	76	10.8
	40mm	1 1/2" BSP	5.25	133	-	9.875	251	3.125	79	12.7
	50mm	2" BSP	6.375	162	-	10.25	260	3.25	83	15.4
Fig 2043 Flanged Bronze or Stainless Steel	15mm	1/2"	5.5	140	130*	8	203	2.375	60	8
	20mm	3/4"	5.625	143	150*	8.25	210	2.5	64	8.6
	25mm	1"	6.75	171	160*	8.375	213	2.625	67	9
	32mm	1 1/4"	7	178	180*	9.625	244	3	76	13.6
	40mm	1 1/2"	7.5	191	200*	9.875	251	3.125	79	16.3
	50mm	2"	8.5	216	230*	10.25	260	3.25	83	20.8
Fig 2044 Flanged Cast Iron (Brz. top)	65mm	2 1/2"	10	254	254	11.75	298	5.25	133	35
	80mm	3"	11.25	286	286	12	305	5.75	146	47
	100mm	4"	13.5	343	343	13.375	340	6.875	175	79
	125mm	5"	16	406	406	16.75	425	9	229	112
	150mm	6"	16.5	419	419	17.625	448	9.75	248	159
	Fig 2045 Flanged Cast Steel (Brz. top)	65mm	2 1/2"	10	254	254	11.25	286	5.125	130
80mm		3"	11.25	286	286	11.25	286	5.75	146	56
100mm		4"	13.5	343	343	12.75	324	7	178	80
125mm		5"	16	406	406	15.75	400	8.625	219	107
150mm		6"	16.5	419	419	16.5	419	9.75	248	174
Fig 2046 Flanged Cast Steel (C.S. top)		15mm	1"	6.75	171	230†	8.375	213	2.75	70
	20mm	1"	6.75	171	230†	8.375	213	2.75	70	13.5
	25mm	1"	6.75	171	230†	8.375	213	2.75	70	13.5
	32mm	2"	9	229	229	10.5	267	3.5	89	26.3
	40mm	2"	9	229	229	10.5	267	3.5	89	26.3
	50mm	2"	9	229	229	10.5	267	3.5	89	26.3
	65mm	2 1/2"	10	254	254	11.25	286	5.125	130	42
	80mm	3"	11.25	286	286	11.25	286	5.75	146	52
	100mm	4"	13.5	343	343	12.75	324	7	178	87
	125mm	5"	16	406	406	15.75	400	8.625	219	124
	150mm	6"	16.5	419	419	16.5	419	9.75	248	173

Face to face dimensions are in accordance with \*Din 3300 (PN40)  
†Din 3300 (PN64)

## Bailey G4 Series

Pilot Operated Pressure  
Reducing Valves

