

HYDRAULIC MOTOR-BRAKE MT/B

APPLICATION

- » Conveyors
- » Metal working machines
- » Agricultural machines
- » Road building machines
- » Mining machinery
- » Food industries
- » Special vehicles
- » Plastic and rubber machinery etc.

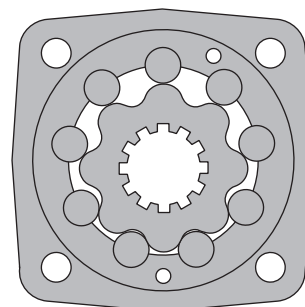
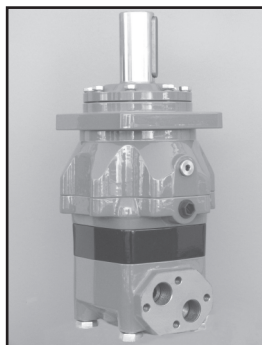

CONTENTS

Specification data	32
Dimensions and mounting	33
Permissible shaft loads	33
Shaft extensions	34
Order code	34

With check valves

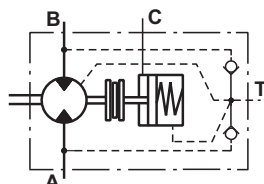

Without check valves "1"

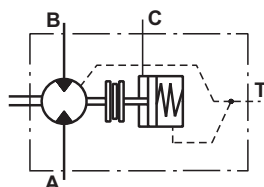

OPTIONS

- » Model - Disc valve, roll-gerotor;
- » Fully integrated friction disk brake;
- » Side ports;
- » Shafts - straight, splined and tapered;
- » BSPP ports
- » Other special features

GENERAL

Max. Displacement, cm ³ /rev [in ³ /rev]	724,3 [44.2]
Max. Speed, [RPM]	780
Max. Torque, daNm [lb-in]	cont.: 130 [11505] int.: 148 [13100]
Max. Output, kW [HP]	40 [54]
Max. Pressure Drop, bar [PSI]	cont.: 200 [2900] int.: 240 [3450]
Max. Oil Flow, lpm [GPM]	150 [40]
Min. Speed, [RPM]	5
Permissible Shaft Loads, daN [lbs]	P _a =1000 [2248]
Pressure fluid	Mineral based- HLP(DIN 51524) or HM(ISO 6743/4)
Temperature range, °C [°F]	-40÷140 [-40÷284]
Optimal Viscosity range, mm ² /s [SUS]	20÷75 [98÷347]
Filtration	ISO code 20/16 (Min. recommended fluid filtration of 25 microns)

Oil flow in drain line

Pressure drop bar [PSI]	Viscosity mm ² /s [SUS]	Oil flow in drain line lpm [GPM]
140 [2030]	20 [98]	2,5 [.66]
	35 [164]	1,5 [.39]
210 [3045]	20 [98]	5 [1.32]
	35 [164]	3 [.79]

Pressure Losses

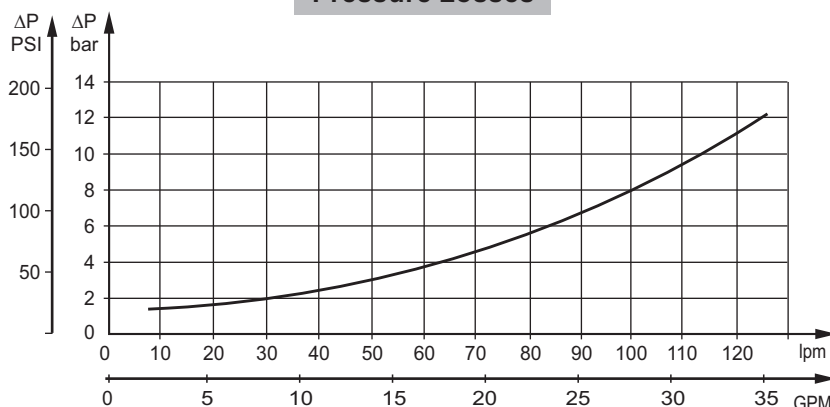

SPECIFICATION DATA

Type	MT/B 160	MT/B 200	MT/B 250	MT/B 315	MT/B 400	MT/B 500	MT/B 630	MT/B 725	
Displacement, cm³/rev [in ³ /rev]	161,1 [9.83]	201,4 [12.29]	251,8 [15.36]	326,3 [19.90]	410,9 [25.06]	523,6 [31.95]	631,2 [38.5]	724,3 [44.2]	
Max. Speed, [RPM]	Cont.	625	625	500	380	305	240	197	172
	Int.*	780	750	600	460	365	285	234	209
Max. Torque daNm [lb-in]	Cont.	47 [4160]	59 [5220]	73 [6460]	95 [8410]	108 [9560]	122 [10800]	130 [11505]	127 [11240]
	Int.*	56 [4960]	71 [6285]	88 [7790]	114 [10090]	126 [11150]	137 [12125]	148 [13100]	147 [13010]
Max. Output kW [HP]	Cont.	26,5 [36]	33,5 [45]	33,5 [45]	33,5 [45]	30 [40]	26,5 [36]	24,3 [33]	20,2 [27]
	Int.*	32 [43]	40 [54]	40 [54]	40 [54]	35 [45]	30 [40]	27,5 [37]	26,8 [36]
Max. Pressure Drop bar [PSI]	Cont.	200 [2900]	200 [2900]	200 [2900]	200 [2900]	180 [2600]	160 [2300]	140 [2030]	120 [1740]
	Int.*	240 [3450]	240 [3450]	240 [3450]	240 [3450]	210 [3050]	180 [2600]	160 [2300]	140 [2030]
Max. Oil Flow lpm [GPM]	Cont.	100 [26.5]	125 [33]	125 [33]	125 [33]	125 [33]	125 [33]	125 [33]	125 [33]
	Int.*	125 [33]	150 [40]	150 [40]	150 [40]	150 [40]	150 [40]	150 [40]	150 [40]
Max. Inlet Pressure bar [PSI]	Cont.	210 [3050]	210 [3050]	210 [3050]	210 [3050]	210 [3050]	210 [3050]	210 [3050]	210 [3050]
	Int.*	250 [3600]	250 [3600]	250 [3600]	250 [3600]	250 [3600]	250 [3600]	250 [3600]	250 [3600]
Max. Return Pressure with Drain Line, bar [PSI]	Cont.	140 [2030]	140 [2030]	140 [2030]	140 [2030]	140 [2030]	140 [2030]	140 [2030]	140 [2030]
	Int.*	175 [2540]	175 [2540]	175 [2540]	175 [2540]	175 [2540]	175 [2540]	175 [2540]	175 [2540]
Max. Starting Pressure with Unloaded Shaft, bar [PSI]	10 [150]	10 [150]	10 [150]	10 [150]	10 [150]	10 [150]	10 [150]	10 [150]	
Min. Starting Torque daNm [lb-in]	At max. pressure drop Cont.	34 [3010]	43 [3800]	53 [4690]	74 [6550]	84 [7435]	95 [8410]	95 [8410]	95 [8410]
	At max. pressure drop Int.*	41 [3630]	52 [4600]	63 [5580]	89 [7880]	97 [8585]	106 [9380]	110 [9735]	115 [10180]
Min. Speed**, [RPM]	10	9	8	7	6	5	5	5	
Static Torque of Brake, daNm [lb-in]	143 [12657]								
Min. Brake Release Pressure***, bar [PSI]	32-35 [464-507]								
Max. Opening Pressure, bar [PSI]	280 [4060]								
Max. Pressure in Drain Line, bar [PSI]	5 [73]								
Weight, kg [lb]	27,5 [60.6]	28 [61.7]	28,5 [62.8]	29,5 [65]	30,5 [67.2]	31,5 [69.4]	31 [68.3]	32 [70.5]	

* Intermittent operation: the permissible values may occur for max. 10% of every minute.

** For speeds lower than given, consult factory or your regional manager.

*** Motor-brakes must always have a drain line. The brake release pressure is the difference between the pressure in the brake release line and the pressure in the drain line.

1. Intermittent speed and intermittent pressure must not occur simultaneously.
2. Recommended filtration is per ISO cleanliness code 20/16. A nominal filtration of 25 micron or better.
3. Recommend using a premium quality, anti-wear type mineral based hydraulic oil HLP (DIN51524) or HM (ISO 6743/4). If using synthetic fluids consult the factory for alternative seal materials.
4. Recommended minimum oil viscosity 13 mm²/s [70 SUS] at 50°C [122°F].
5. Recommended maximum system operating temperature is 82°C [180°F].
6. To assure optimum motor life fill with fluid prior to loading and run at moderate load and speed for 10-15 minutes.

DIMENSIONS and MOUNTING DATA

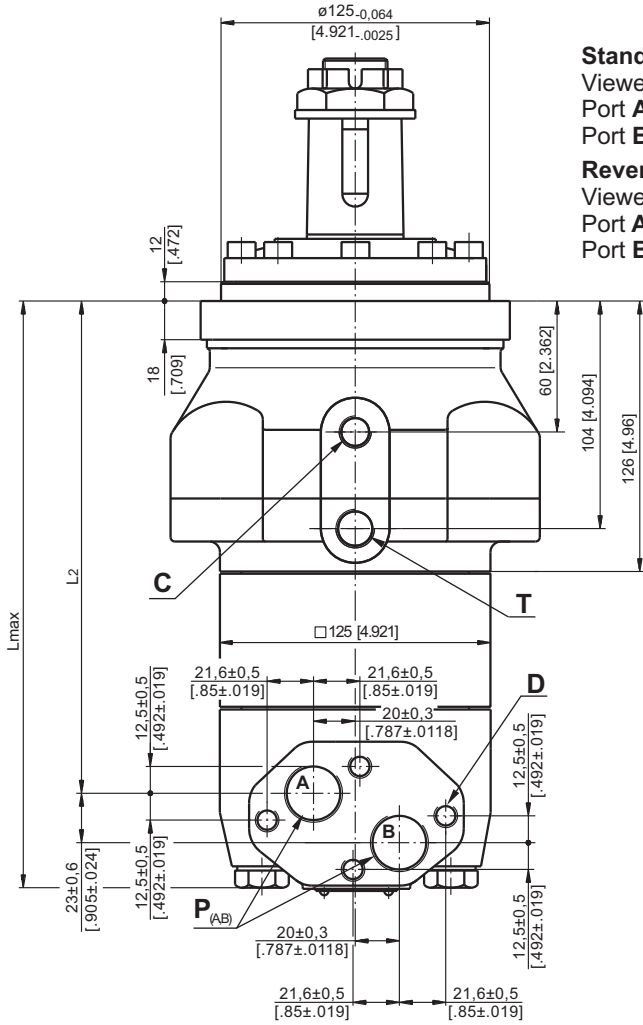

Standard Rotation
Viewed from Shaft End
Port A Pressurized - CW
Port B Pressurized - CCW

Reverse Rotation
Viewed from Shaft End
Port A Pressurized - CCW
Port B Pressurized - CW

Shaft Dim.
See Page 35

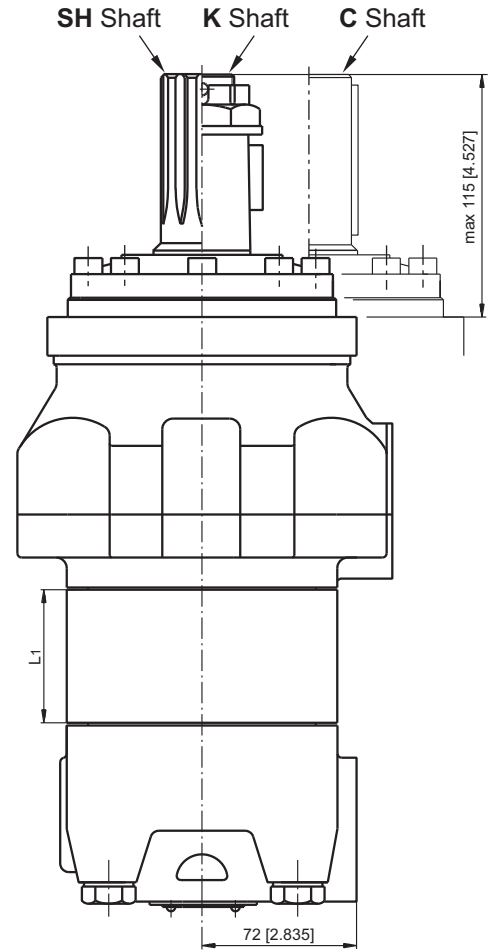

- P_(A,B)** - 2xG3/4, 17 mm [.669] depth
- C** - Brake release port, G1/4, 12 mm [.472 in] depth
- T** - Drainage tap, G3/8, 13 mm [.512] depth
- D** - 4xM10, 10 mm [.394] depth

PERMISSIBLE SHAFT LOADS

The curve applies to a B10 bearing life of 3000 hours at 200 RPM.
Max. permissible radial shaft load with a safety factor of 3:1.

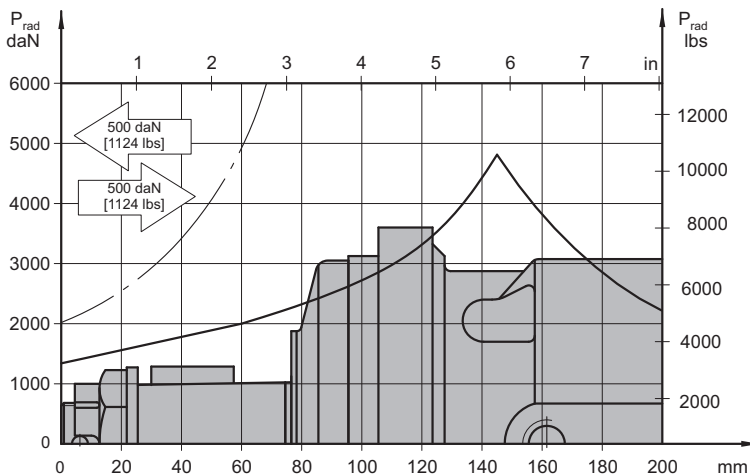

Warning: Drain line should always be used.

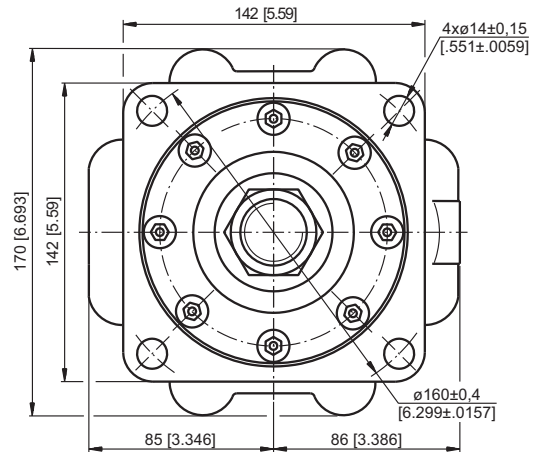

Type	*L1, mm [in]	L2, mm [in]	Lmax, mm [in]
MT/B 160	17 [.67]	178 [7.01]	228 [8.98]
MT/B 200	22 [.87]	183 [7.21]	233 [9.17]
MT/B 250	28,3 [1.11]	189,3 [7.45]	239 [9.41]
MT/B 315	37,5 [1.48]	198,5 [7.81]	248 [9.76]
MT/B 400	48 [1.89]	209 [8.23]	259 [10.2]
MT/B 500	62 [2.44]	223 [8.78]	273 [10.8]
MT/B 630	58 [2.28]	219 [8.62]	269 [10.6]
MT/B 725	67 [2.64]	228 [8.98]	278 [10.9]

* The width of the gerotor is
3,5 mm [.138 in] greater than L₁.

SHAFT EXTENSIONS

C - ϕ 40 straight, Parallel key A12x8x70 DIN 6885
Max. Torque 123 daNm [10886 lb-in]

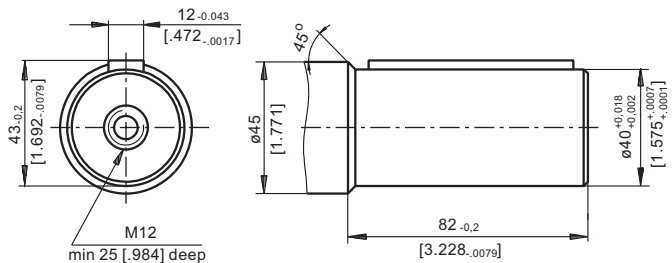

SH - ϕ 1½" splined 17T, DP 12/24 ANSI B92.1-1976
Max. Torque 123 daNm [10886 lb-in]

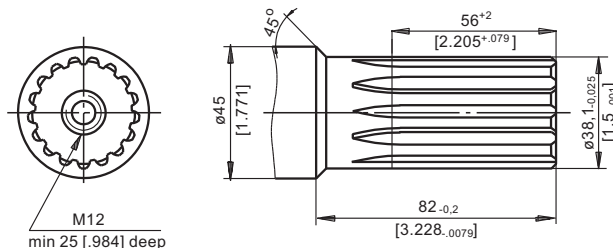

K -tapered 1:10, Parallel key B12x8x28 DIN 6885
Max. Torque 210 daNm [18587 lb-in]

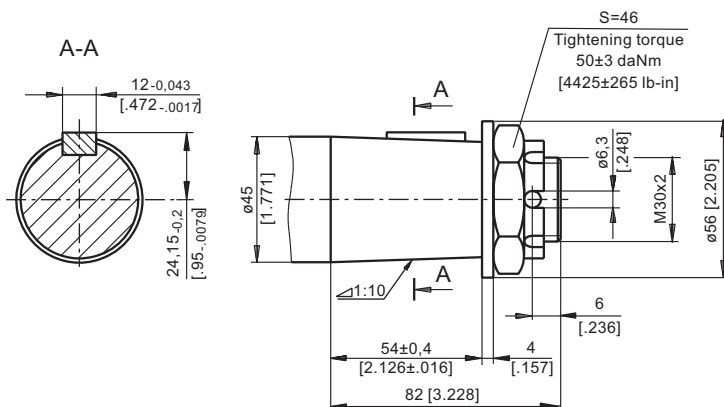

ORDER CODE

	1	2	3	4	5
MT/B					

Pos.1 - Displacement code

160	- 161,1 cm ³ /rev [9.83 in ³ /rev]
200	- 201,4 cm ³ /rev [12.29 in ³ /rev]
250	- 251,8 cm ³ /rev [15.36 in ³ /rev]
315	- 326,3 cm ³ /rev [19.90 in ³ /rev]
400	- 410,9 cm ³ /rev [25.06 in ³ /rev]
500	- 523,6 cm ³ /rev [31.95 in ³ /rev]
630	- 631,2 cm ³ /rev [38.50 in ³ /rev]
725	- 724,3 cm ³ /rev [44.20 in ³ /rev]

Pos.2 - Shaft Extensions*

C	- ϕ 40 straight, Parallel key A12x8x70 DIN6885
SH	- ϕ 1½" splined 17 DP12/24 ANS B922.1-76
K	- ϕ 45 tapered 1:10, Parallel key B12x8x28 DIN 6885

Pos.3 - Check Valves

omit	- with check valves
1	- without check valves

Pos.4 - Special Features (see page 72)

Pos.5 - Design Series

omit - Factory specified

NOTES:

* The permissible output torque for shafts must not be exceeded!

The motor-brakes are manganophosphatized as standard.