



EVRM-NC
EVRM-6NC

Safety solenoid valves for gas
Manual reset - Normally closed
DN10 ... DN300

EVRM-NC

EVRM-6NC

Safety solenoid valves for gas
Manual reset - Normally closed

Contents

Description	2
Features	2
Functioning and application	3
Technical specifications	4
Gas flow chart (pressure drop)	6
Ordering information	8
Special versions and optionals	8
Design, installation and servicing	9
Standards and approvals	10

Description

The EVRM-NC /6NC type valve is a manual reset safety valve that is normally closed (open when energized). This type of device, connected to one or more gas leakage detectors, safety thermostat or alarm signals for the presence of carbon monoxide, is suitable to perform locking operations on the gas line.

Features

The valves are made of aluminum alloy die-cast (or hot-pressed brass for OT versions), with a wide range for inlet/outlet connections from DN10 up to DN 300.

Pipe connections meet group 2, according to EN161 requirements.

Suitable for use with air and non-aggressive gases included in the 1, 2 and 3 families (EN 437). Special versions for aggressive gases (Biogas).



The whole range can be provided in Ex-proof execution, for use in Zones 2 and 22, according to 94/9/EC Directive (ATEX).

Two range of operating pressure: low pressure (0...600 mbar) and medium pressure (0...6 bar).

The valve is open only when energized: if, for any reason, power supply goes down, the valve closes immediately (intrinsic safe).

An incorporated fine mesh filter protects the valve seat and disc as well as downstream components and prevents dirty contamination (except brass models).

Provided with G1/4 pressure gauge on two sides in the inlet chamber (except brass models), to connect manometers, pressure switches, leakage tester or other gas equipments. Flanged models are provided with gauges also in the outlet chamber.

The coils are provided with ISO 4400 plug or with terminal box for DN100 or bigger. Both systems are provided with suitable cable gland to avoid water and dirty contamination.

All components are designed to withstand any mechanical, chemical and thermal condition occurring during typical service. Effective impregnation and surface treatments have been used to improve mechanical sturdiness, sealing and resistance to corrosion of the components.

Valves are 100% tested by computerized testing machineries and are fully warranted.



WARNING

This control must be installed in compliance with the rules in force.

Functioning and application

The EVRM-NC type valve is a manual reset safety valve that is normally closed. When not in working position the spring works on the shutter keeping the gas orifice closed. Simply by energizing the coil the valve does not open. It is necessary to manually move the reset rod located at the top of the coil. Once opened, the valve can maintain this position until electric current circulates on the coil. In absence of electric current the valve closes rapidly and remains shut upon return of same. Once the causes for the lock have been eliminated, valve must be opened manually as described above.

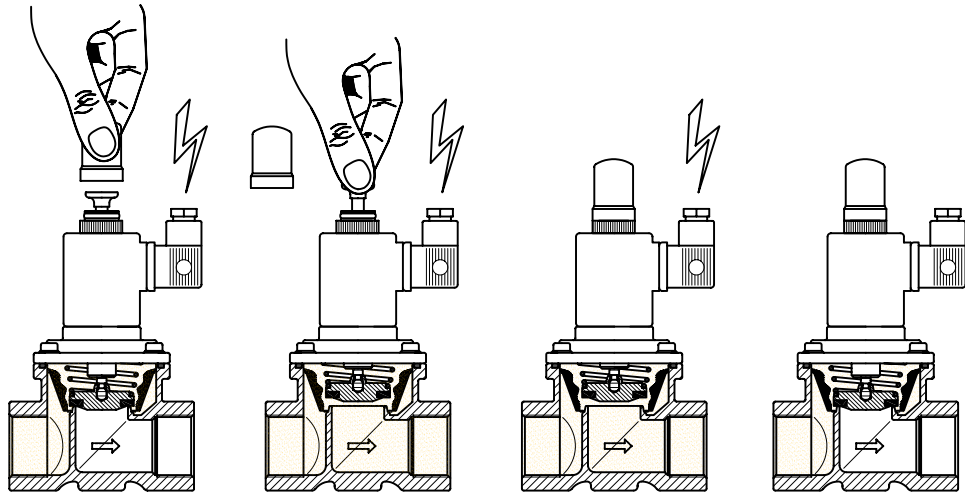

Fig.1



The models from DN125 or bigger and the 6 bar versions are provided with a dual-shutter system for pressure compensation. To open the valve pull the knob for the first step, wait for pressure compensation, and then pull the knob completely up to full resetting.

This kind of device is normally installed downstream a manual shut-off valve and upstream of the gas regulating train. Figure 2 shows a example of installation.

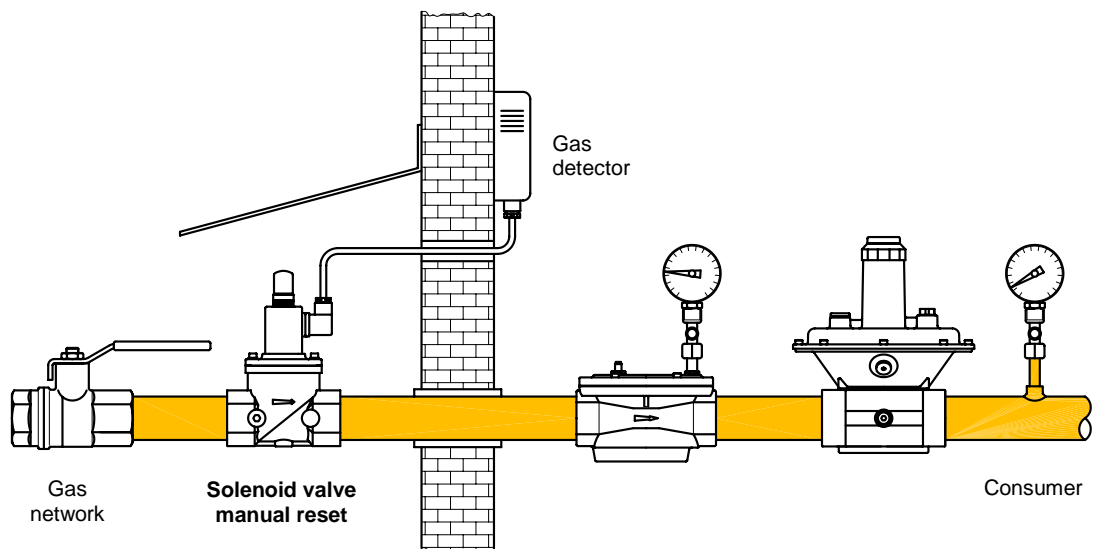

Fig.2



WARNING

Location and mode of installation must be in compliance with local rules in force.

Technical specifications

Tab. 1

Connections	Gas threaded ISO 7-1 from Rp3/8 to Rp2½ Flanged PN16 – ISO 7005 from DN40 to DN300
Voltage rating	230 VAC 50/60 Hz 110 VAC 50/60 Hz 24 VAC/DC 12 VAC/DC
Voltage tolerance	-15% / +10%
Power consumption	see charts
Ambient temperature	-15°C / +60°C
Max. operating pressure	600 mbar (60 kPa) 6 bar (600 kPa)
Flow capacity	see charts
Closing time	< 1 second
Filter (except brass models)	600 µm, metal mesh
Protection class (EN 60529)	IP65 models with DIN plug DN10..DN80 IP54 models with terminal box DN100..DN300 (IP65 optional)
Cable gland	PG 9 models with DIN plug DN10..DN80 M20 models with terminal box DN100..DN300
Coil winding insulation	Class H (200°C)
Coil thermal resistance	Class F (155°C)
Materials in contact with gas	Aluminium alloy Brass Stainless steel Plated steel Anaerobic adhesive Nitrile rubber (NBR)

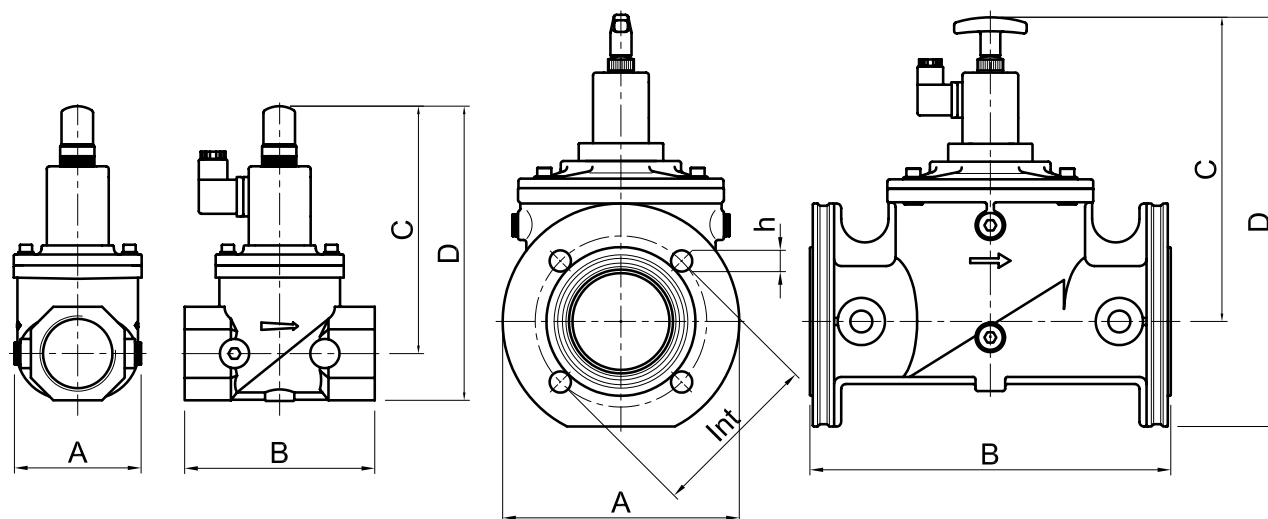

Fig.3

Tab. 2

Material and connections		Power consumption @230VAC [W]	Flow factor Kvs [m³/h]	Overall dimensions [mm]						Weight [Kg]
CuZn	AlSi			A	B	C	D	Int	h	
Rp 3/8		8	0,7	30	58	115	130	-	-	0,4
Rp 1/2		8	1,3	30	58	115	130	-	-	0,4
G 3/4		8	2,0	35	55	113	130	-	-	0,6
G 1		8	4,5	40	62	115	137	-	-	0,7
	Rp 3/8	12	2,9	70	77	148	164	-	-	0,9
	Rp 1/2	12	4,8	70	77	148	164	-	-	0,9
	Rp 3/4	12	9,5	85	96	158	180	-	-	1,1
	Rp 1	12	12	85	96	158	180	-	-	1,1
	Rp 1 1/4	12	22	120	153	188	220	-	-	2
	Rp 1 1/2	12	29	120	153	188	220	-	-	2
	Rp 2	12	40	106	156	192	230	-	-	2,3
	DN 40 ⁽¹⁾	12	29	150	193	188	262	110	4x18	3,7
	DN 50 ⁽¹⁾	12	40	165	196	192	274	125	4x18	4,3
	Rp 2 1/2	25	65	175	218	249 ⁽²⁾	297 ⁽²⁾	-	-	5,5
	DN 65	25	65	200	305	262 ⁽²⁾	352 ⁽²⁾	145	4x18	7,6
	DN 80	25	80	200	305	262 ⁽²⁾	352 ⁽²⁾	160	8x18	7,6
	DN 100	35	148	252	350	305 ⁽²⁾	435 ⁽²⁾	180	8x18	17
	DN 125	35	250	310	460	370 ⁽²⁾	540 ⁽²⁾	210	8x18	29
	DN 150	35	315	310	460	370 ⁽²⁾	540 ⁽²⁾	240	8x23	31
	DN 200	35	516	370	546	425 ⁽²⁾	635 ⁽²⁾	295	12x23	46
	DN 250	35	660	405	600	485 ⁽²⁾	712 ⁽²⁾	355	12x28	72
	DN 300	35	1120	460	700	523 ⁽²⁾	786 ⁽²⁾	410	12x28	99

⁽¹⁾ Optional Kit ⁽²⁾ Valve open

Gas flow chart
(Pressure drop)

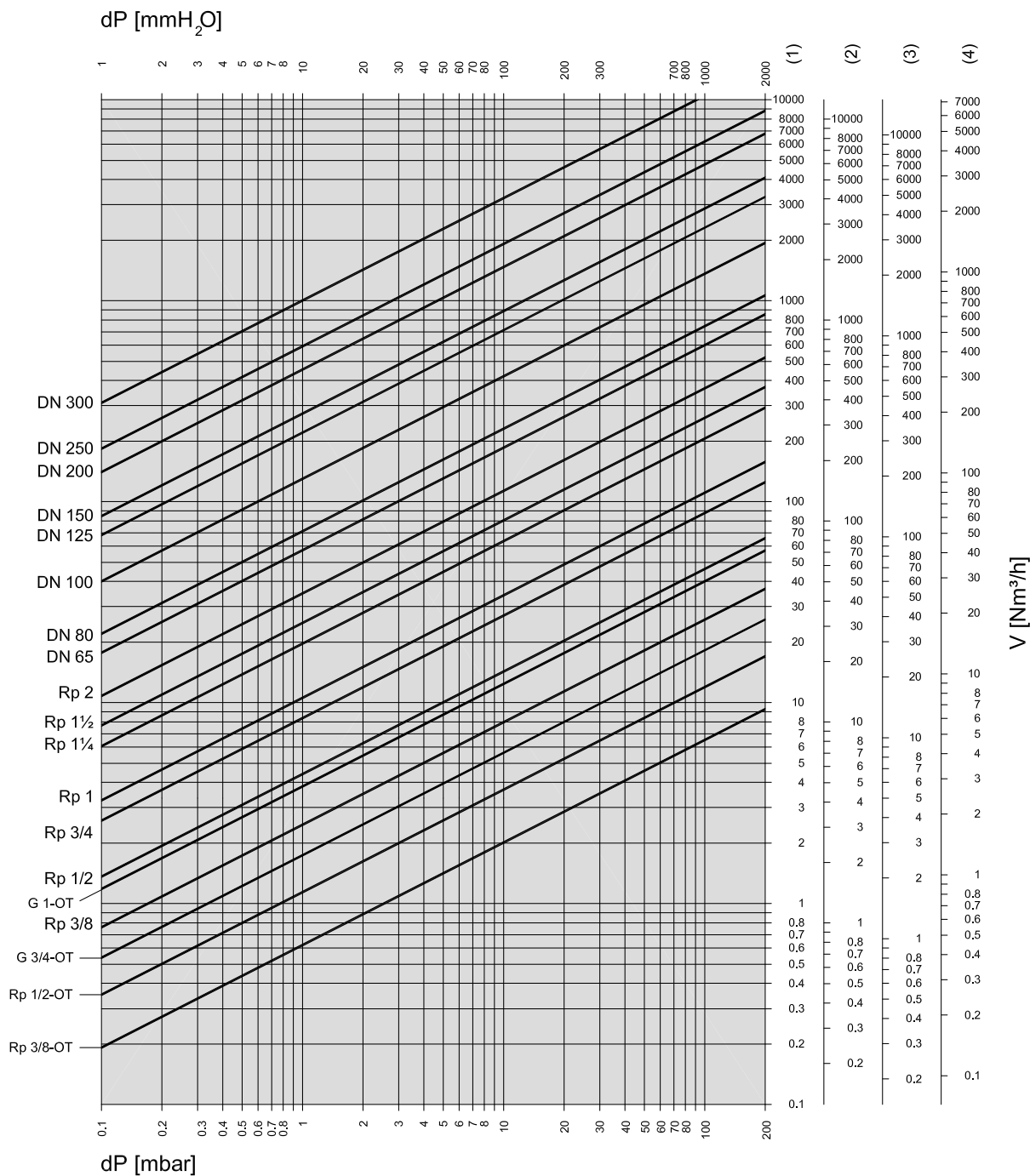

Fig. 4

**Formula of conversion
from air to other gases**

$$V_{GAS} = k \cdot V_{AIR}$$

Tab. 3

Gas type	Specific gravity ρ [Kg/m ³]	$k = \sqrt{\frac{1.25}{\rho_{GAS}}}$
(1) Air	1,25	1,00
(2) Natural gas	0,80	1,25
(3) Town gas	0,57	1,48
(4) LPG	2,08	0,77

15°C, 1013 mbar, dry

When the flow read on the diagram is referred to operating pressure instead of standard conditions, the pressure drop Δp read on the diagram must be multiplied for the factor: (1+ relative pressure in bar)

Example:

In the 2" solenoid valve with an air flow of 80 Nm³/h there is a pressure drop $\Delta p = 5$ mbar. If we consider that 80 m³/h is the flow at 200 mbar of inlet pressure, then the pressure drop to be consider is:

$$\Delta p = 5 \times (1 + 0,2) = 6 \text{ mbar}$$

Normally, pressure drop and flow rate for the valves are read from the gas flow diagram. However, the valves can also be chosen in accordance with the characteristic "Kvs value" which is shown in table 2.

The selection of the valve requires the calculation of the Kv under the operating conditions.

Considering only subcritical pressure drops:

$$\Delta p < \frac{p_1}{2}$$

Kv can be calculated with the formula:

$$Kv = \frac{V}{514} \sqrt{\frac{\rho(t + 273)}{\Delta p \cdot p_2}}$$

where

- V = flow rate [Nm³/h]
- Kv = flow factor [m³/h]
- ρ = density [Kg/m³]
- p₁ = absolute inlet pressure [bar]
- p₂ = absolute outlet pressure [bar]
- Δp = differential pressure p₁-p₂ [bar]
- t = media temperature [°C]

To the Kv value calculated from operating conditions we add an allowance of 20%, to obtain the minimum Kvs value which the valve should have:

$$Kvs > 1,2 Kv$$



Valve must be selected considering the following:

- Pressure drops $\Delta p \leq 0,1 p_1$ are recommended and $\Delta p > p_1/2$ are always unadvisable
- Flow velocities $w \leq 15$ m/s are recommended and $w > 50$ m/s are always unadvisable.

Ordering information

Tab.4

Designation (230V)		Connections	Additional code for special voltages		
600 mbar	6 bar		110 VAC	24 V AC/DC	12 V AC/DC
EVRMNC00	EVRM6NC00	Rp 3/8 brass			
EVRMNC10	EVRM6NC10	Rp 1/2 brass			
EVRMNC20	EVRM6NC20	G 3/4 brass	–		
EVRMNC30	EVRM6NC30	G 1 brass			
EVRMNC0A	EVRM6NC0A	Rp 3/8			
EVRMNC1A	EVRM6NC1A	Rp 1/2			
EVRMNC2A	EVRM6NC2A	Rp 3/4			
EVRMNC3A	EVRM6NC3A	Rp 1			
EVRMNC35A	EVRM6NC35A	Rp 1¼			
EVRMNC4A	EVRM6NC4A	Rp 1½			
EVRMNC6A	EVRM6NC6A	Rp 2			
EVRMNC4AF	EVRM6NC4AF	DN 40 ⁽¹⁾		C	D
EVRMNC6AF	EVRM6NC6AF	DN 50 ⁽¹⁾	B		
EVRMNC7AT	EVRM6NC7AT	Rp 2½			
EVRMNC7A	EVRM6NC7A	DN 65			
EVRMNC8A	EVRM6NC8A	DN 80			
EVRMNC9	EVRM6NC9	DN 100			
EVRMNC93	EVRM6NC93	DN 125			
EVRMNC95	EVRM6NC95	DN 150			
EVRMNC98	EVRM6NC98	DN 200			
EVRMNC910	EVRM6NC910	DN 250			
EVRMNC912	EVRM6NC912	DN 300			

NOTE: models up to DN80 are provided with DIN plug, models from DN100 up to DN300 are provided with terminal box.

⁽¹⁾ Optional kit

Special versions and optionals

The sizes 1"¼, 1"½ and 2" can be provided with G1/4 gauges also in the outlet chamber.

A closed position indicator micro-switch (CPI) can be installed. Models from DN65 to DN300 are provided with G1/8 connection on the bottom for these facilities -on request from 3/8" to 2" - (not available for brass models).

The threaded models Rp1½ and Rp2 can be provided with flanged connections using an optional kit.

The whole range can be provided with a special cable gland and Ex-proof marking for use in Zones 2 and 22, according to 94/9/EC Directive (ATEX):

category	II 3 G,D
protection mode	Ex n A II T4 X, Ex tD A 22 IP54 T135 X

J-version: the models with aluminum body from 3/8" to 6" can be supplied in special versions for aggressive gases such as biogas, they are free of non-ferrous metals in contact with gas and provided with special seals.

S-version: the models from 5" to 12" can be supplied without the inner piston for indirect acting.



The versions with inlet pressure $p_1 \leq 6$ bar (600 kPa) may be order inserting the digit "6" in to the designation.

Different voltage than 230V may be order adding to the standard designation the additional code shown above. Other optionals must be order with their ordering code.

Example: EVRM6NC3A.B for a valve with Rp1 connections, 110VAC, 6 bar



Manufacturer reserves the right to update or make technical changes without prior notice.

Design, installation and servicing

To assure a proper and safe operation, as well as a long service life of the valve, consider the following recommendations during the design of the system where the valve will be installed:



- ✓ Ensure that all the features of your system comply with the specifications of the valve (gas type, operating pressure, flow rate, ambient temperature, electrical voltage, etc.).
- ✓ Valve may be mounted with coil in horizontal or vertical position, not upside down.
- ✓ In the event of vertical pipe, the flow direction should be from bottom to top.
- ✓ After removing the end caps make sure no foreign body will enter into the valve during handling or installation (e.g. swarf or excessive sealing agent).
- ✓ A gas filter should be always installed upstream the valve.
- ✓ Ensure that installing area is protected from rain and water splashes or drops.
- ✓ Never install the valve close to walls or other equipments.
- ✓ Perform leak and functional tests after mounting (max. testing pressure 1,5 Pmax).
- ✓ Check proper operation at least once a year (most often for aggressive gases).
- ✓ Due to seals aging, to ensure safe operation, we recommend the valve replacement after 10 years from the date of manufacture stamped on the product.
- ✓ This control must be installed in compliance with the rules in force.
- ✓ Make sure all works are performed by qualified technicians only and in compliance with local and national codes.
- ✓ To prevent product damage and dangerous situations, read carefully the instructions supplied with the product before use.

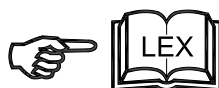

Standards and approvals

The valve design meets current European approval requirements regarding safety shut-off functions on gaseous fuels.

These products conform with the Pressure Equipment Directive (97/23/EC) and the certification has been issued by the notified body:



C.S.I. Spa
Viale Lombardia 20
I-20021 Bollate (MI)



The following standards/technical specifications have been fulfilled:

- ATEX (94/9/EC) when shown upon the product
- Electromagnetic Compatibility (2004/108/EC)
- Low Voltage Directive (2006/95/EC)
- RoHS II (2011/65/UE)

The valves comply with the Technical Regulation 753 of Russian Federation concerning the security of machinery and equipment and the certification has been issued by the Body



«INTERCERT» Ltd
Str. Profsoyuznaya, 93 A, of. 423
RU-117279 Moscow

Certificate No.: C-IT.AB86.B.04357

Quality Management System is certified according to UNI EN ISO 9001 and the monitoring is carried out by the notified body:

Kiwa Gastec Italia Spa.
Via Treviso, 32/34
I- 31020 San Vendemiano (TV)

