

Alco Controls™

FF 4 Pressure Controls 0.11 to 250 bar

Technical Bulletin

Applications:

- Air compressors
- Water pumps
- Booster pumps
- Fire-fighting equipment
- Oil supply equipment
- High-pressure cleaning apparatus

Features

- Large space for cable mounting
- Easy to adjust
- Separate screw for upper and lower switching-point setting
- Accurate scale
- Transparent, UV-resistant cover
- Protection class: IP65
- Worldwide approvals
- High repeatability of set switch-points



FF 4
Pressure Controls 0.11 to 250 bar

Introduction

ALCO FF 4 series of pressostats are suitable for a wide range of industrial and commercial applications. Their functions, as pressure switches, limiters or cut-outs can be utilized for:

- Monitoring and controlling the pressure of liquid or gaseous media in pipelines, tanks, vats, pressure vessels and apparatus.
- Duties in process control, cooling, pneumatics and hydraulics.
- Pressure monitoring of cooling circuits and lubrication systems on various types of machinery.
- Automatic switching of pump and compressor motors for supplying water to dwellings, booster pumps, fire-fighting equipment and on compressed air systems.

Mode of operation

The pressure of the monitored medium operates against a flat diaphragm, bellows or a plunger (depending on pressure range). A system of levers and springs works on a snap-action cascade switch of high resistance to vibration, ensuring flutter-free switching.

Low pressure on the diaphragm closes contact 1-2. This can be used as a "RUN" signal for a pump or compressor motor.

If pressure exceeds the upper switching-point, contact 1-2 opens and contact 1-4 closes. The applied motor will be switched off. Contact 1-4 is often used to indicate the "off" condition.

Contact 1-2 will close again, when the pressure on the diaphragm has decreased below the set lower switch-point.

Included in standard units:

- Rubber grommet with hole for cable entry
- Nylon strap to secure cable
- Installation an operating instructions

Upper and lower switch points can be adjusted independently of each other using a screwdriver. The two switch points are indicated on the scale inside the unit.

Construction

Pressure connection, pressure sensing element, switch mechanism and electrical terminals are fitted on a silumin base. Scale and switch are protected against environmental effects by an impact-resistant, transparent polycarbonate cover, which is creepage resistant (CTI 200/100M) and can be lead-sealed.

New: Pressure connector "Y", made out of plastic for demineralized water applications.

Options upon request

- Gold plated contacts
- Cable gland Pg 13,5 for higher protection IP 65
- Indicator lamp for switching condition
- Viton diaphragm for aggressive media
- Manual reset
- GL -approved versions
- UL-/CSA-approved versions
- Throttle section H138-043 for FF 4-2 to FF 4-32
- Other pressure connectors. Contact your local ALCO CONTROLS wholesaler for availability
- Special screw for lead seal cover



FF 4 Pressure Controls 0.11 to 250 bar

| Type | Part Code Nr. | Upper switch point adjustable from ... to bar | Lower switch point adjustable from ... to bar | Smallest differential at lower ... higher end of range | max. operating pressure bar | max. test pressure bar | Standard settings bar |
|------|---------------|---|---|--|-----------------------------|------------------------|-----------------------|
|------|---------------|---|---|--|-----------------------------|------------------------|-----------------------|

Pressure controls with perbunan diaphragm

VDE 0660, EN 60947-5-1

for mineral oils, water and air.

Pressure connector: H (G $\frac{3}{8}$ " female, DIN ISO 228/l)

| | | | | | | | |
|-------------|-----------|------------|---------------|-----------|----|----|-----------|
| FF 4-2 DAH | 0 182 129 | 0.11 ... 2 | 0.04 ... 1.89 | 0.07 0.11 | 20 | 40 | 0.5 / 1.5 |
| FF 4-4 DAH | 0 182 131 | 0.22 ... 4 | 0.07 ... 3.75 | 0.15 0.25 | 24 | 40 | 1 / 3 |
| FF 4-8 DAH | 0 182 143 | 0.5 ... 8 | 0.2 ... 7.5 | 0.3 0.5 | 30 | 40 | 2 / 6 |
| FF 4-16 DAH | 0 182 156 | 1 ... 16 | 0.4 ... 15 | 0.6 1 | 36 | 48 | 4 / 12 |
| FF 4-32 DAH | 0 182 168 | 2 ... 32 | 0.8 ... 30 | 1.2 2 | 52 | 64 | 10 / 20 |

Pressure controls with perbunan diaphragm

VDE 0660, EN 60947-5-1

and plastic pressure connector for demineralized water.

Pressure connector: Y (G $\frac{3}{8}$ " female, DIN ISO 228/l)

| | | | | | | | |
|-------------|-----------|------------|---------------|-----------|----|----|-----------|
| FF 4-2 DAY | 0 714 440 | 0.11 ... 2 | 0.04 ... 1.89 | 0.07 0.11 | 6 | 12 | 0.5 / 1.5 |
| FF 4-4 DAY | 0 714 441 | 0.22 ... 4 | 0.07 ... 3.75 | 0.15 0.25 | 8 | 12 | 1 / 3 |
| FF 4-8 DAY | 0 714 442 | 0.5 ... 8 | 0.2 ... 7.5 | 0.3 0.5 | 12 | 16 | 2 / 6 |
| FF 4-10 DAY | 0 714 475 | 0.7 ... 10 | 0.3 ... 9.2 | 0.4 0.8 | 12 | 16 | 4 / 5 |
| FF 4-16 DAY | 0 714 443 | 1 ... 16 | 0.4 ... 15 | 0.6 1 | 20 | 24 | 4 / 12 |

High pressure controls with plastic plunger

VDE 0660, EN 60947-5-1

These pressure switches operate with a plastic plunger, which is resistant to detergents, de-greasing and polish-removal agents. The **FF 4-60 PAH ... FF 4-250 PAH** pressostats are thus particularly suitable for use on high-pressure cleaning

apparatus. Throttle screw H 115-115.001 is fitted as standard inside the pressure connection on these units. This must be removed for use with viscous media.

Pressure connector: H (G $\frac{3}{8}$ " female, DIN ISO 228/l)

| | | | | | | | |
|--------------|-----------|------------|------------|-------|-----|-----|-----------|
| FF 4-60 PAH | 0 183 412 | 8 ... 60 | 4 ... 52 | 4 8 | 100 | 120 | 20 / 40 |
| FF 4-120 PAH | 0 183 424 | 16 ... 120 | 8 ... 104 | 8 16 | 200 | 240 | 20 / 80 |
| FF 4-250 PAH | 0 038 594 | 30 ... 250 | 14 ... 226 | 12 24 | 400 | 500 | 100 / 200 |

FF 4 Pressure Controls 0.11 to 250 bar

Pressure controls with perbunan diaphragm

VDE 0170/0171, VDE 0660, EN 60947-5-1

Flat diaphragm, resistant to mineral oils. UL-file: E 85 974

Pressure connector: F (¼"-18 NPTF per ANSI B 1.20.3 - 1976)

| Type | Part Code Nr. | Upper switch point adjustable from ... to P.S.I.G | Lower switch point adjustable from ... to P.S.I.G | Smallest differential at lower ... higher end of range | | max. operating pressure P.S.I.G | max. test pressure P.S.I.G | Standard settings P.S.I.G |
|---------------|---------------|---|---|--|-----|---------------------------------|----------------------------|---------------------------|
| FF 444-V1 DAF | 0 097 308 | 1 ... 29 | ½ ... 27 | 1 | 2 | 290 | 580 | 7 / 22 |
| FF 444-V2 DAF | 0 097 309 | 3 ... 58 | 1 ... 54 | 2 | 4 | 348 | 580 | 14 / 44 |
| FF 444-V3 DAF | 0 097 310 | 7 ... 116 | 3 ... 109 | 4 | 7 | 435 | 580 | 29 / 87 |
| FF 444-V4 DAF | 0 097 311 | 15 ... 232 | 6 ... 218 | 9 | 14 | 522 | 696 | 58 / 174 |
| FF 444-V5 DAF | 0 097 312 | 29 ... 464 | 12 ... 435 | 17 | 29 | 769 | 928 | 145 / 290 |
| FF 444-V6 PAF | 0 153 299 | 116 ... 870 | 58 ... 754 | 58 | 116 | 1450 | 1740 | 290 / 580 |
| FF 444-V7 PAF | 0 153 300 | 232 ... 1740 | 116 ... 1508 | 116 | 232 | 2900 | 3480 | 290 / 1160 |
| FF 444-V8 PAF | 0 153 301 | 435 ... 3625 | 203 ... 3277 | 174 | 348 | 5800 | 7250 | 1450 / 2900 |

Pressure controls for fire-protection plant

Especially demanding requirements regarding quality and functional reliability are placed on pressure switches intended for pressure monitoring on fire-protection equipment.

FF 4-.. VdS are approved for use in fixed watersprinkler installations by the German Association of Insurers (Verband der Sachversicherer)

VdS-approved

FF 4-2 VdS is a typical alarm pressure switch. The setting range is limited to 1 bar. Differential lever and spring are omitted to assure a minimum resetting differential.

FF 4-10 VdS and FF 4-16 VdS pressure switches limit the switching differential to 1.5 bar maximum.

Pressure connector: I (G ½ female, DIN ISO 228/I)

| Type | Part Code Nr. | Upper switch point adjustable from ... to bar | Lower switch point adjustable from ... to bar | Smallest differential at lower ... higher typ max bar | | max. operating pressure bar | max. test pressure bar | Standard settings bar |
|-----------------|---------------|---|---|---|-----|-----------------------------|------------------------|-----------------------|
| FF 4-2 VdS DAI | 3 334 200 | 0.5 ... 1 | 0.4 ... 0.9 | 0.1 fixed | | 20 | 40 | 0.6 / 0.7 |
| FF 4-10 VdS DAI | 3 318 700 | 0.7 ... 10 | 0,3... 8.5 | 0.5 | 1.5 | 32 | 40 | 4 / 5 |
| FF 4-16 VdS DAI | 3 334 300 | 1 ... 16 | 0.4 ... 15 | 0.8 | 1.5 | 36 | 48 | 11 / 12 |

Technical data

| Rated operational current at 230 V | |
|---------------------------------------|-------|
| Non-Inductive Amp. (AC1) | 16 A |
| Inductive Amp. (AC15) | 6 A |
| Inductive Amp. (DC11) | 0.1 A |
| Motor rating, Full load Amp. (FLA) | 10 A |
| Motor rating, Locked rotor Amp. (LRA) | 60 A |

| Protection to DIN 40 050 T9 / IEC 529 | |
|--|-------------|
| with rubber grommet | IP 54 |
| with cable gland Pg 13.5 or appliance socket | IP 65 |
| Ambient temperature range, standard pressure connector | -20...+70°C |
| Ambient temperature range, plastic pressure connector | 0...+50°C |
| Resistance to vibration, 10 to 1000 Hz | 4g |

Switch Point Diagrams (all units in bar)

FF 4-2

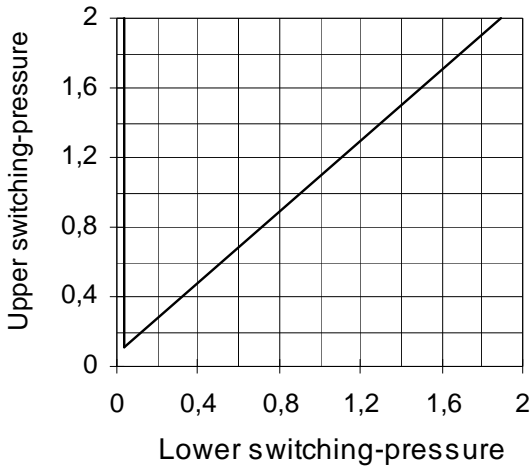

FF 4-4

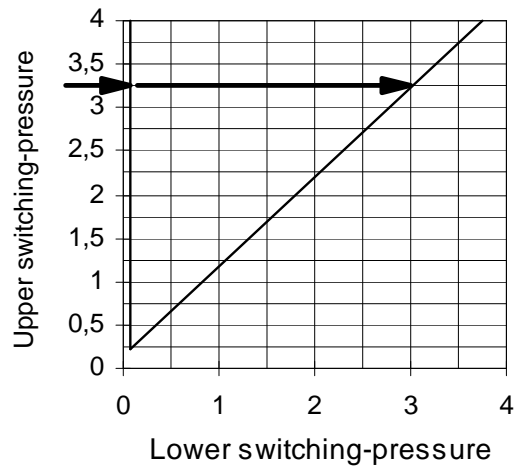

FF 4-8

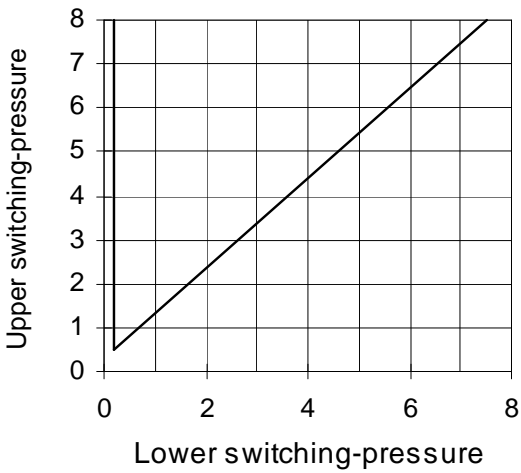

FF 4-16

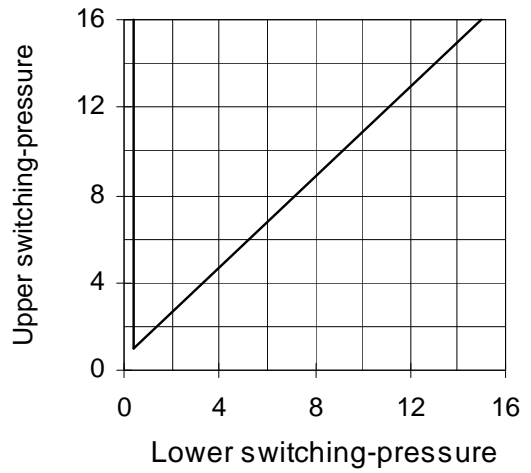

Above charts show the smallest adjustable differential.

Example per figure FF 4-4:

If upper setting is at 3.25 bar, lower setting can be adjusted between 0.07 and 3.0 bar (see arrows in the drawing).

FF 4-32

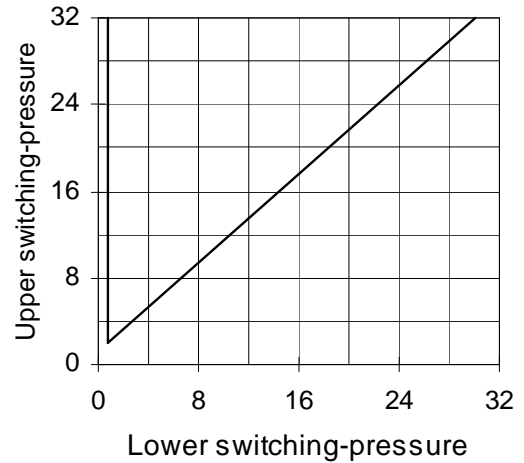

FF 4-60

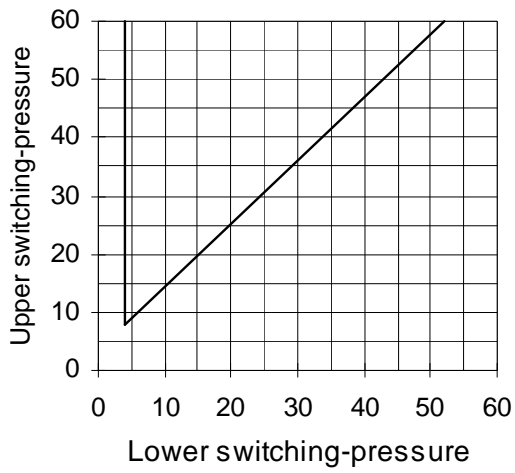

FF 4-120

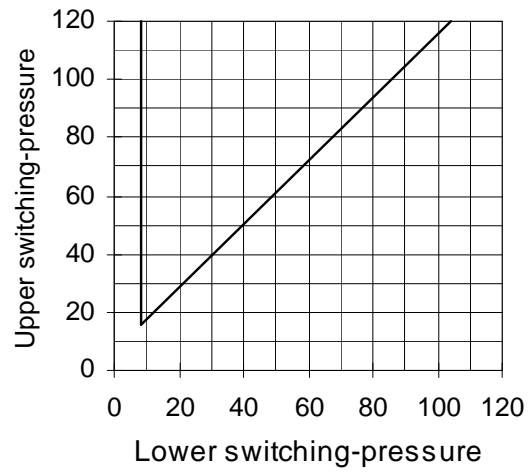

Above charts show the smallest adjustable differential.

Example per figure FF 4-4:

If upper setting is at 3.25 bar, lower setting can be adjusted between 0.07 and 3.0 bar (see arrows in the drawing).

FF 4-250

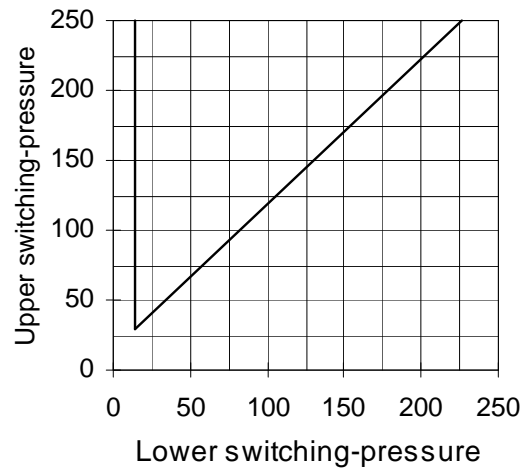

FF 4 Pressure Controls 0.11 to 250 bar

Dimensions:

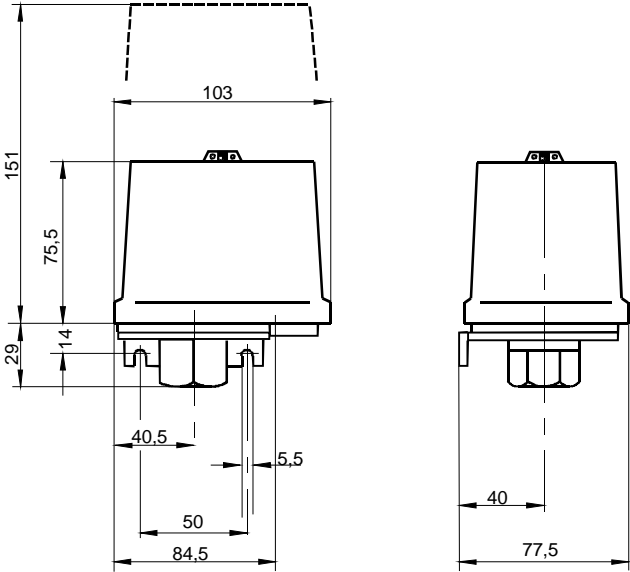

FF 4-2, FF 4-4, FF 4-8, FF 4-16, FF 4-32

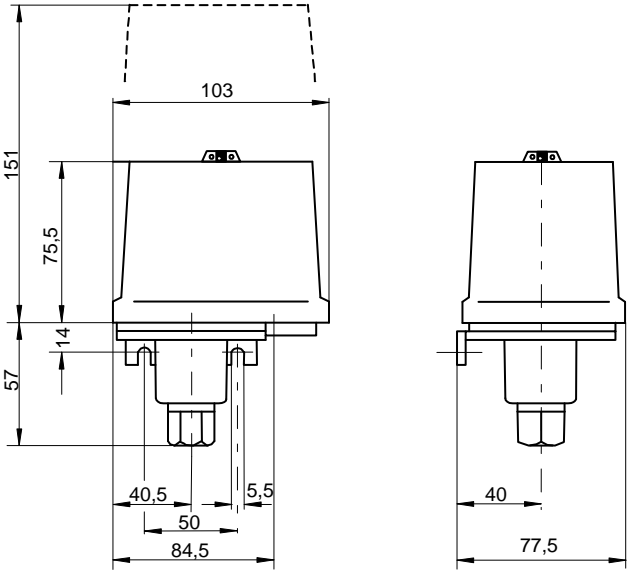

FF 4-60, FF 4-120, FF 4-250

FF 4 Pressure Controls 0.11 to 250 bar

Accessories

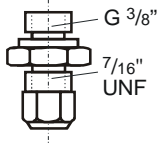

**Brass gland for
6 x 1 copper tube**

Type: R- $7/16$ " UNF FN 262 Ms
Part Code Nr. 0526 842
Weight: ~0.18 kg

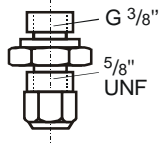

**Brass gland for
10 x 1 copper tube**

Type: R- $5/8$ " UNF FN 262 Ms
Part Code Nr. 0526 830
Weight: ~0.18 kg

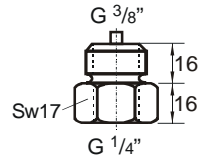

**Nipple, Steel,
G $3/8$ - G $1/4$ female**

Type: H 124-141
Part Code Nr. 0136 857
Weight: ~0.085 kg

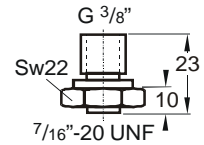

**Nipple, Brass,
G $3/8$ - $7/16$ "-20 UNF, female**

Type: H124-202.1
Part Code Nr. 0137 051
Weight: ~0.05 kg

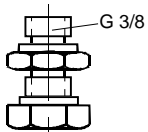

**Steel Ermeto connector for
Ø 6 mm steel pipe**

Type: R-AD 6-FN 43
Part Code Nr. 0405 466
Weight: ~0.1 kg

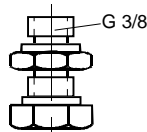

**Steel Ermeto connector for
Ø 10 mm steel pipe**

Type: R-AD 10-FN 43
Part Code Nr. 0405 478
Weight: ~0.1 kg

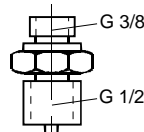

**Steel manometer fitting
G $3/8$ - G $1/2$**

Type: H 124-114
Part Code Nr. 0403 358
Weight: ~0.18 kg



Throttle screw for FF 4-2 ...-32

Type: H 138-043
Part Code Nr. : 0021 485
Weight: ~0.003 kg

Pressure Connectors

Contact your local ALCO CONTROLS wholesaler for availability of these pressure connectors with the pressostat of your choice.

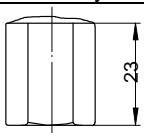
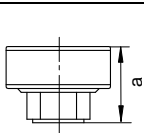
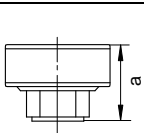
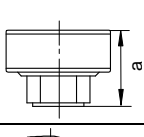
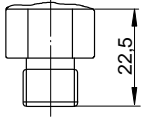
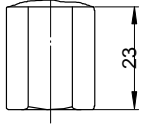
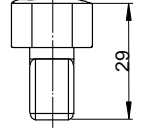
| | | | | | |
|--|--|---|--|---|--|
|  | Code: G G $1/4$ female, brass / steel DIN ISO 228/1 |  | Code: H G $3/8$ female, silumin DIN ISO 228/1 |  | Code: I G $1/2$ female, silumin DIN ISO 228/1 |
| | |  | Code: Y G $3/8$ female, polyamid DIN ISO 228/1 | | |
|  | Code: R G $1/4$ A male, brass DIN ISO 228/1 |  | Code: F $1/4$ "-18 NPTF female ANSI B 1.20.3 - 1976 |  | Code: N $1/4$ "-18 NPTF male ANSI B 1.20.3 - 1976 |