

Thermostatic Control Valve

Model B

Typical applications

- Lubricating oil temperature control
- Jacket water high temperature (HT)
- Secondary water low temperature (LT)
- Heat recovery
- Water saving applications
- Boiler inlet temperature control
- Co-generation, cooling towers
- Temperature mixing or diverting
- Engine and compressor cooling system



Model B

Key benefits

- No external power source required
 - Simple, low cost installation
- No user setting needed
 - 'Fit and forget' solution
- Small number of parts
 - Simple maintenance and low cost of ownership
- Robust design capable of high vibration and shock applications
- Easy installation, operates in any mounting position
- Automatic self-sensing control with positive proportional valve action

Key features

- Flow rates of 15 - 400 m³/hr (68 - 1750 US gpm)
- Combinations available:
 - Housings in cast iron, ductile iron, bronze, carbon steel, stainless steel
- DN40 - DN200 (1 ½" - 8") pipe sizes
- Threaded and flanged connections
- Tamper-proof temperature settings from 13°C - 116°C (55°F - 240°F)
- Pressure ratings up to 45 bar (655 psi)

Accreditations available

- PED Suitable for Group 1 & 2 liquids (Ensure materials are compatible)
- ATEX  II 2G Ex h IIC T6...T3 Gb X
- CE Complies with all relevant EU directives



Thermostatic Control Valve - Model B

Contents

Overview	3
Applications	4
Valve Characteristics	4
Pressure drop	4
Flow coefficient	5
Viscosity correction	6
Viscosity correction curve	6
SAE oils viscosities	6
Available versions	7
Port connections	7
Temperature and element characteristics	7
Element type and seal material	7
How to Order	8
Maximum Working Pressures	9
Specification	9
Weights	9
Valve Dimensions	10
Maintenance and Service Parts	11
Ordering from Americas and Canada	11
Service kits	11
Service kit model number structure	11
Ordering from Europe and Asia-PAC	11
Seal kits	11
Element(s)	11
Seal kit model number structure	12
Element part number structure	12
Service parts	13
Contact	15

Thermostatic Control Valve - Model B

Overview

AMOT Model B thermostatic valves are available in a wide selection of sizes and settings to fill a multitude of fluid temperature control requirements. These valves may be mounted in any position and use the proven expanding wax principle to actuate the 3-way temperature element assemblies. The model B valves may be used for diverting or mixing service.

They make very economical temperature limiting valves for engine and lubricating oil cooling, and to prevent scalding in hot water supply systems; such as in emergency water systems for labs. Radiant heating systems can use these valves in limiting water temperature to prevent surface cracking and over-heating of plastic piping. Other applications include electronic and battery cooling circuits, pump temperature relief valves etc.

Housing materials

- Cast iron
- Steel
- Ductile iron
- Bronze
- Stainless steel

Seal materials

- Buna N/Nitrile
- Viton
- Neoprene

Element materials

- A combination of bronze, brass and stainless steel (standard)
- A combination of nickel plated and stainless steel

Leakholes

In some applications, it is necessary to have leak holes drilled in the element to ensure a small flow between ports A and C. Leak holes are available in sizes ranging from 1.6 mm - 12.7 mm ($1/16''$ - $1/2''$).

Please refer to the Leakhole size (G) section of the valve selection table on page 8 to determine the hole size required for specific applications.

Temperature settings

A wide selection of element materials, seals, and temperatures are available. Follow the equipment manufacturers' guidelines for heating/cooling systems.

Temperature settings are available from 13°C - 116°C (55°F - 240°F). Refer to the temperature and element characteristics table on page 7 for specific temperature settings. In general, the temperature quoted is the nominal operating temperature in diverting mode on water systems.

For long life, AMOT valves should not be operated continuously at temperatures in excess of 14°C (25°F) of their maximum continuous rating. If this condition is anticipated then consult AMOT for suitable alternatives.

For mixing and oil circuits the temperature may be one to two degrees higher due to flow, viscosity and other system parameters. Elements and seals are available in a variety of materials. These materials are suitable for most applications. Please contact AMOT for material compatibility information.

Manual override (BM & BR)

Model BM

For BM type valves, in automatic mode the valve will control the temperature automatically, but actuating the manual override mechanism(s) on top of the valve will move the element(s) to the fully extended (hot) position, regardless of temperature. Each element assembly has its own manual override.

Model BR

BR type valves are fitted with a manual override which allows a progressive opening of port A to C. Manual override is often a requirement for marine applications. Each element assembly has its own manual override.

Manual override should only be used in case of an emergency or element failure.

Thermostatic Control Valve - Model B

Applications

Diverting Applications

When valves are used for diverting services, the inlet is Port A (temperature sensing port), with Port C being connected to the cooler, and Port B connected to the cooler by-pass line.

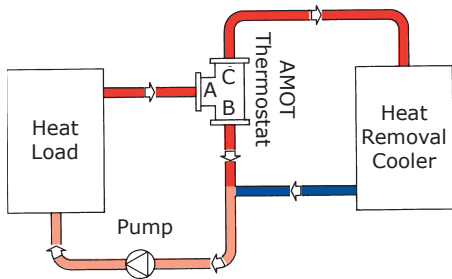

Mixing Applications

When valves are used for mixing service, Port C is the cold fluid inlet port from the cooler, Port B is the hot by-pass fluid inlet, and Port A the common outlet. Port A is the temperature sensing port and will mix the hot and cold fluids in the correct proportion so as to produce the desired outlet temperature leaving Port A.

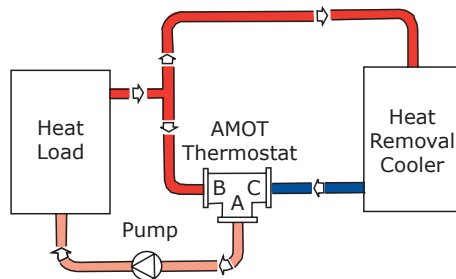

2-Way Water Saving Applications

Valve as shown maintains minimum flow through cooler to conserve water. Requires internal leak hole to permit small flow for sensing.

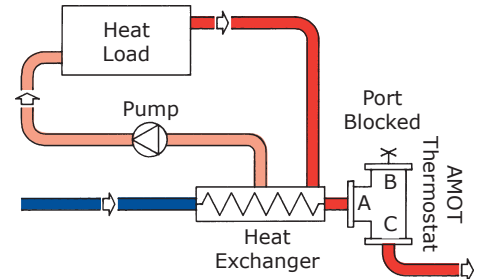

Valve Characteristics

Pressure drop (Metric units)

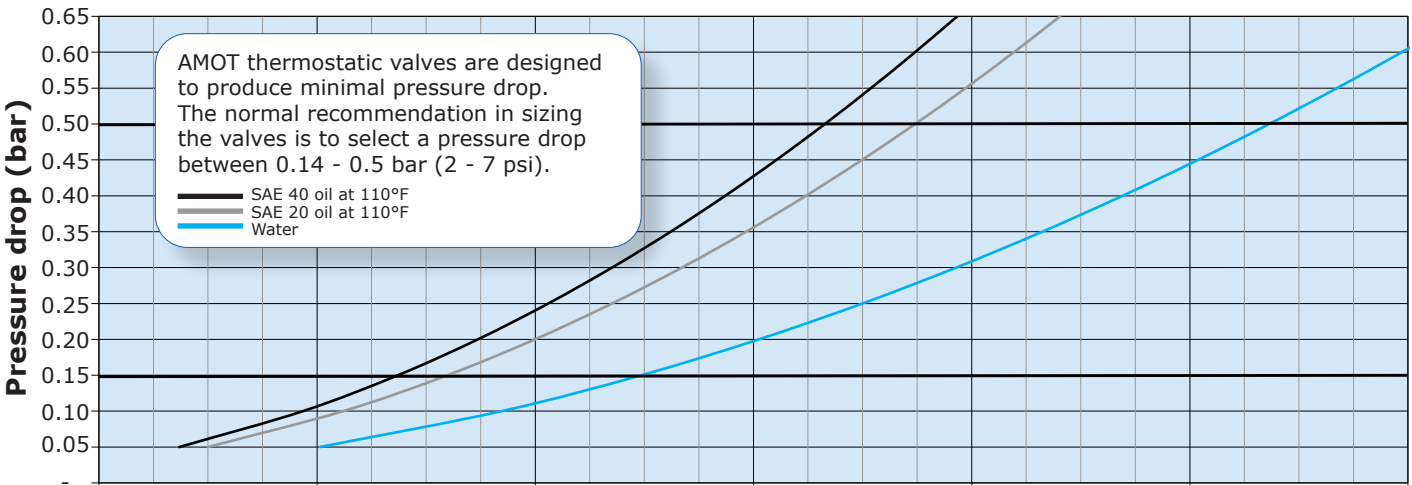

Size	8	12	16	20	24	28
1 1/2	8	12	16	20	24	28
2	10	15	20	24	29	34
2 1/2	18	26	35	44	53	61
3	19	29	39	48	58	68
33	27	40	54	67	81	94
4	39	59	78	98	117	137
5	58	88	117	146	175	205
6	88	131	175	219	263	306
8	127	190	254	317	381	444

Flow rate (m³/hr) - Water

Thermostatic Control Valve - Model B

Valve Characteristics Continued

Pressure drop (English units)

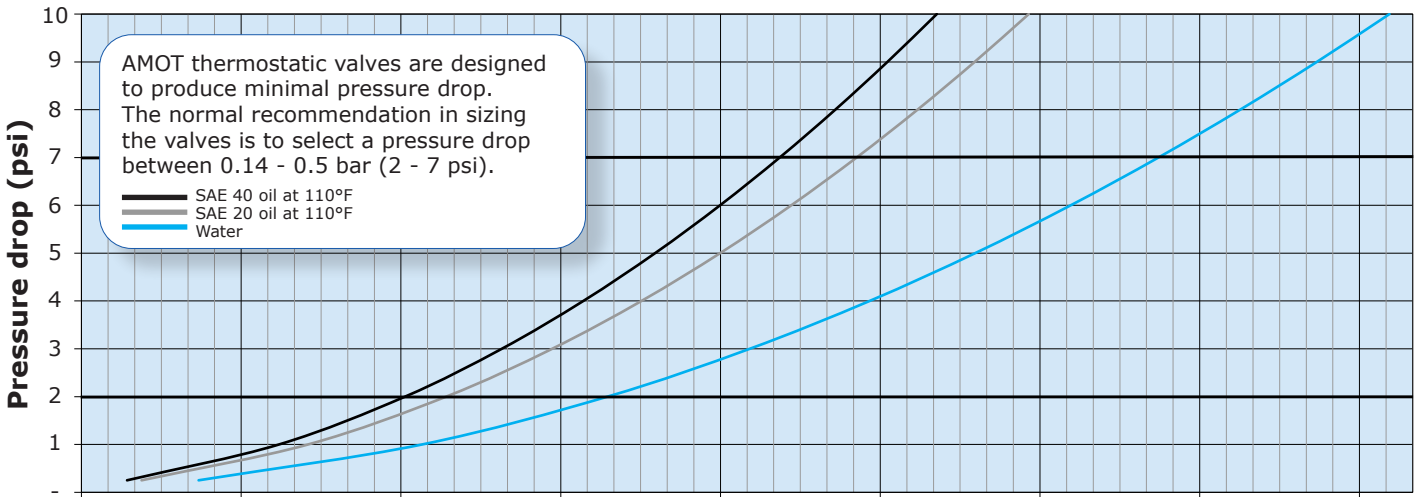

Size	◆	◆	◆	◆	◆	◆	◆	◆
1 ½	25	40	55	70	85	100	115	130
2	30	49	67	85	103	121	140	158
2 ½	52	83	114	145	176	207	238	269
3	60	96	132	168	204	240	277	313
33	83	133	183	233	283	333	383	433
4	121	193	266	338	411	483	556	628
5	181	290	398	507	615	724	832	941
6	271	434	597	760	923	1,086	1,249	1,411
8	393	629	864	1,100	1,336	1,571	1,807	2,043

Flow rate (US gpm) - Water

Flow coefficient

Flow coefficient (calculated)		
Size	Kv	Cv
1 ½	36	42
2	44	51
2 ½	79	91
3	87	101
33	121	140
4	176	203
5	263	304
6	394	456
8	571	660

Kv is the flow coefficient in metric units. It is defined as the flow rate in cubic meters per hour (m³/hr) of water at a temperature of 16° Celsius with a pressure drop across the valve of 1 bar. The basic formula to find a valve's Kv is shown below:

$$Kv = Q \sqrt{\frac{SG}{DP}} \quad Q = Kv \sqrt{\frac{DP}{SG}} \quad DP = \left[\frac{Q}{Kv} \right]^2 SG$$

Q = Flow in m³/hr
 DP = Pressure drop (bar)
 SG = Specific gravity of fluid (Water = 1.0)
 Kv = Valve flow coefficient (Metric units)

Cv is the imperial coefficient. It is defined as the flow rate in US Gallons per minute (gpm) of water at a temperature of 60° Fahrenheit with a pressure drop across the valve of 1 psi. The basic formula to find a valve's Cv is shown below:

$$Cv = Q \sqrt{\frac{SG}{DP}} \quad Q = Cv \sqrt{\frac{DP}{SG}} \quad DP = \left[\frac{Q}{Cv} \right]^2 SG$$

Q = Flow in US Gallons/Min
 DP = Pressure drop (psi)
 SG = Specific gravity of fluid (Water = 1.0)
 Cv = Valve flow coefficient (English units)

Kv = 0.865 Cv

Cv = 1.156 Kv

Thermostatic Control Valve - Model B

Valve Characteristics Continued

Viscosity correction

For the selection of valves for use with more viscous fluids than water, the following must be calculated in addition to using the previously mentioned formulae:

- Viscosity

Find the viscosity of the fluid to be used in the valve. This will generally be in centistokes (cST).

ISO grade oil is easy to calculate as the grade no. is the viscosity.

I.e. ISO VG 46 = 46 centistokes at 43°C (110°F)

- Viscosity correction

Once the viscosity value has been found, the flow coefficient correction factor can be established using the viscosity correction graph below.

The correction value (Fv) that is produced by the graph should then be multiplied by the original flow coefficient. This gives the corrected flow coefficient, which can then be used in the standard formula.

e.g.:

100 cST = correction factor of 0.68

0.68 x flow co. = corrected flow co. (Kv or Cv)

Viscosity correction curve (Fv)

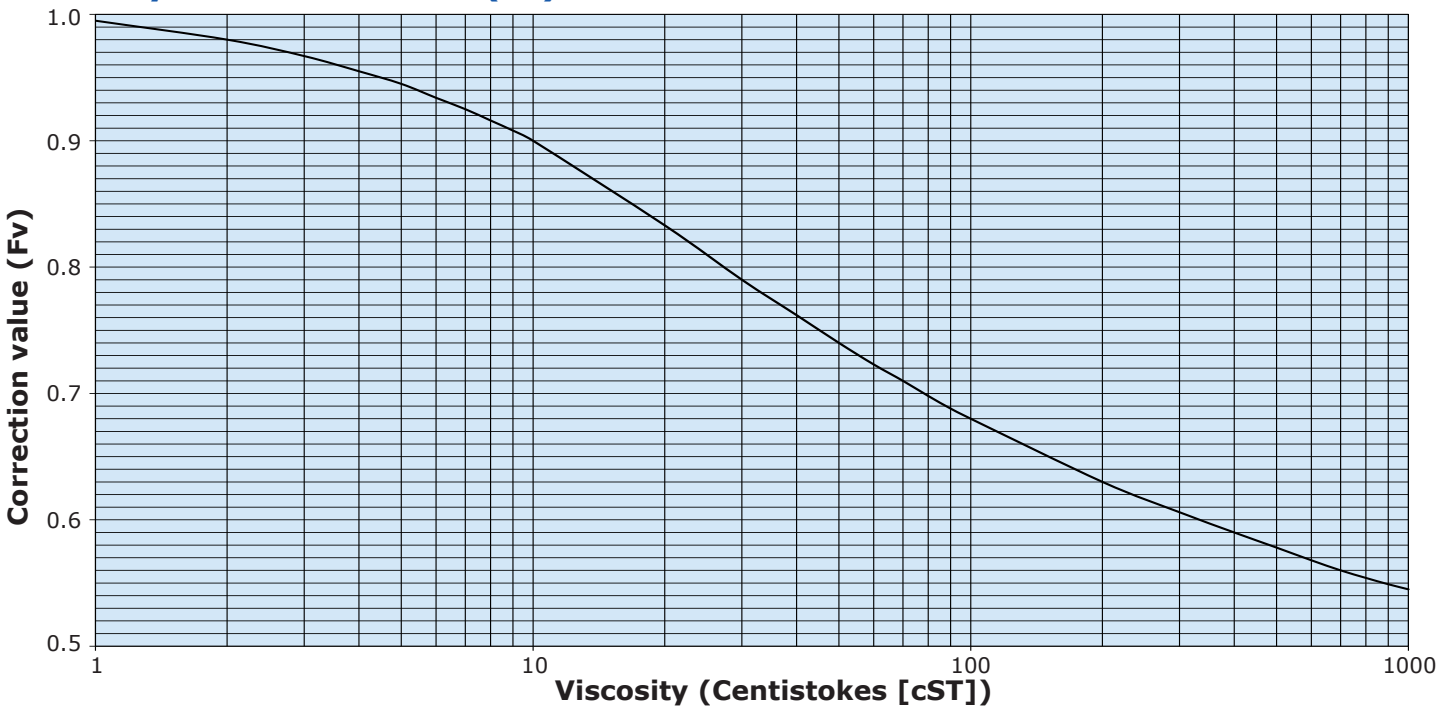

SAE oils viscosities

Engine oils	
Oil	cST
SAE 5W	6.8
SAE 10W	32
SAE 20	46
SAE 20W	68
SAE 30	100
SAE 40	150
SAE 50	220

Gear oils	
Oil	cST
SAE 75W	22
SAE 80W	46
SAE 85W	100
SAE 90	150
SAE 140	460

Approximate viscosities of SAE oils at 43°C (110°F) (cST).

Based on leading oil manufacturers' published data.

Thermostatic Control Valve - Model B

Valve Characteristics Continued

Available versions

Cast iron	Ductile iron	Bronze	Steel/ Stainless Steel
Threaded	Threaded	Threaded	Threaded
1 ½ BG/BH/BO	1 ½ BO	1 ½ BO	1 ½ / 2 BO
2 BH/BO	Flanged	2 BO	Flanged
Flanged	2 BC/BF/BM/BR	Flanged	2 BC/BM/BR/BF
2 BC/BF/BG/BM/BR	2 ½ BF/BM/BO/BR	1 ½ BM	2 ½ BM/BO/BR
2 ½ BM/BO/BR	3 BM/BO/BR	2 BC/BF/BM/BR	3 BM/BO/BR
3 BM/BO/BR	4 BM/BO/BR	2 ½ BM/BO/BR	4 BO/BR
33 BO/BR	5 BM/BO/BR	3 BM/BO/BR	5BM/BO/BR
4 BM/BO/BR	6 BM/BO/BR	4 BM/BO/BR	6BM/BO/BR
5 BM/BO/BR	8 BO/BR	5 BM/BO/BR	8BM/BO/BR
6 BM/BO/BR		6 BM/BO/BR	
8 BO/BR		8 BO/BR	

Port connections

Flanged		Threaded	
Code	Description	Code	Description
A	PN6	T	NPT
B	PN10	U	BSP (PL)
C	PN16		
F	ASME 125 lb		
H	ASME 300 lb		
J	ASME 150 lb		
K	ASME 600 lb		
L	JIS 10K		
P	JIS 5K		

Temperature and element characteristics

Code	Control temp.		Rated range				Max temp. cont.	
	°C	°F	Crack open		Full open		°C	°F
			°C	°F	°C	°F		
055	13	55	8	47	20	68	35	95
057	14	57	10	50	18	65	30	86
068	20	68	14	57	26	79	40	104
075	24	75	20	68	30	86	38	100
090	32	90	27	81	35	95	43	110
095	35	95	29	85	41	105	49	120
100	38	100	34	93	42	108	50	122
105	41	105	35	95	45	113	55	131
110	43	110	38	100	47	117	56	133
115	46	115	40	104	50	122	61	142
120	49	120	43	110	54	130	66	150
130	54	130	51	124	60	140	68	155
135	57	135	54	129	63	145	71	160
140	60	140	57	135	66	151	74	165
145	63	145	60	140	69	156	79	174
150	66	150	63	145	72	161	82	180
155	68	155	66	150	74	165	85	185
160	71	160	68	155	78	173	88	190
165	74	165	71	160	79	175	88	190
170	77	170	74	165	83	181	93	200
175	79	175	77	170	85	185	102	215
180	82	180	79	175	88	191	104	220
185	85	185	82	180	91	196	106	223
190	88	190	85	185	94	201	107	224
195	91	195	87	188	98	209	107	225
205	96	205	93	200	102	215	108	226
215	102	215	98	209	107	225	115	239
225	107	225	102	216	113	236	118	244
230	110	230	104	219	115	239	118	244
240	116	240	108	227	122	252	123	254

Element type and seal material

Code	Element type	Element construction	Seal material
01	1096X	Standard	Buna N/Nitrile
02	1096P	Nickel plated	Viton
03	1096X	Standard	Viton
05	6836S	Saltwater	Buna N/Nitrile
07	2433X	Standard manual override	Buna N/Nitrile
08	2433P	Nickel plated manual override	Viton
09	6938S	Saltwater manual override	Buna N/Nitrile
11	5566X	Short stroke, high overtemp.	Buna N/Nitrile
20	5566X	Short stroke, high overtemp.	Viton
44	1096X	Standard	Neoprene
45	1096P	Nickel plated	Neoprene
53	2433X	Standard manual override	Viton
66	48920X	Standard with SS cage & sliding valve	Buna N/Nitrile
67	49580X	Standard manual override with SS cage & sliding valve	Buna N/Nitrile
70	48920X	Standard with SS cage & sliding valve	Viton
71	49580X	Standard manual override with SS cage & sliding valve	Viton

Thermostatic Control Valve - Model B

Maximum Working Pressures

Measurements in bar (psi)

Material	Valve size and model									
	1 ½ B	2 B	2 BG/BH	2 ½ B	3 B	33 B	4 B	5 B	6 B	8 B
Bronze	10 (150)	10 (150)	-	10 (150)	10 (150)	-	10 (150)	10 (150)	10 (150)	10 (150)
Cast iron	10 (150)	10 (150)	22 (320)	10 (150)	10 (150)	6 (87)	10 (150)	10 (150)	10 (150)	10 (150)
Ductile iron	-	16 (230)	-	16 (230)	16 (230)	-	16 (230)	10 (150)	10 (150)	10 (150)
Steel/Stainless steel	45 (655)	45 (655)	-	45 (655)	45 (655)	-	20 (290)	20 (290)	15 (218)	15 (218)

NOTE: Certain flange options will lower the maximum working pressure of the valve. e.g. Choosing PN6 flanges (Port connection (D) = A) will give 6 bar (87 psi) maximum working pressure.

Specification

	Metric units	English units
Flow rate	15 - 400 m ³ /hr	68 - 1750 US gpm
Body materials	Bronze: Seawater, shock resistance and low magnetic permeability Cast iron: Fresh water and lubricating oils Ductile iron: High performance iron Steel: High strength/pressure ratings Stainless steel: Corrosive and special applications	
Seal materials	Buna N/Nitrile, Viton and Neoprene	
Mounting position	Any orientation	
Ports	Below nominal temperature: Ports A and B connected Above nominal temperature: Ports A and C connected	
Port connections	Screwed: 40 and 50 mm BSP (PL) or NPT 1 ½" and 2" BSP (PL) or NPT Flanged: 50 - 200 mm DIN, ASME, JIS 2" - 8" DIN, ASME, JIS	
Valve sizes (nominal bore)	40, 50, 65, 80, 100, 120, 150 and 200 mm 1 ½", 2", 2 ½", 3", 4", 5", 6" and 8"	
Control temperatures	13 - 116 °C 55 - 240 °F	
Accreditations available	PED: 40 - 150 mm (1 ½" - 6") inclusive suitable for Group 1 & 2 liquids. 50 - 80 mm (2" - 3") with Port connection (D) = H (300 lb flanges) and 200 mm (8") suitable for Group 2 liquids only. (Ensure materials are compatible)	
	ATEX	 II 2G Ex h IIC T6...T3 Gb X
	CE	Complies with all relevant EU directives

Weights

Approximate weights in kg (lbs)

Material	Valve size and model													
	1 ½ BG/BH	1 ½ BM	1 ½ BO	2 BC/BM/BR	2 BF	2 BG/BH	2 BO	2 ½ B	3 B	33 B	4 B	5 B	6 B	8 B
Bronze	-	13 (29)	13 (29)	26 (57)	22 (49)	-	13 (29)	29 (64)	36 (79)	-	68 (150)	109 (240)	136 (300)	315 (694)
Cast iron/Ductile iron	11 (24)	-	11 (24)	18 (40)	18 (40)	11 (24)	11 (24)	24 (53)	27 (59)	35 (77)	61 (134)	91 (201)	123 (271)	285 (628)
Steel/Stainless steel	-	-	13 (29)	20 (44)	22 (49)	-	13 (29)	34 (75)	36 (79)	-	61 (134)	92 (203)	137 (302)	371 (818)

Thermostatic Control Valve - Model B

Valve Dimensions

Note: Contact AMOT for detailed outline drawings when required.

1 1/2" - 2" BG/BH/BO

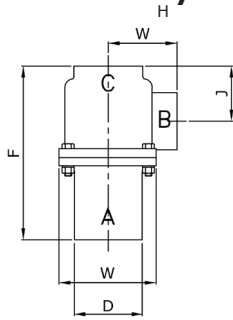

2" BF

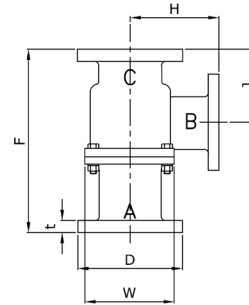

2" BC/BM/BR

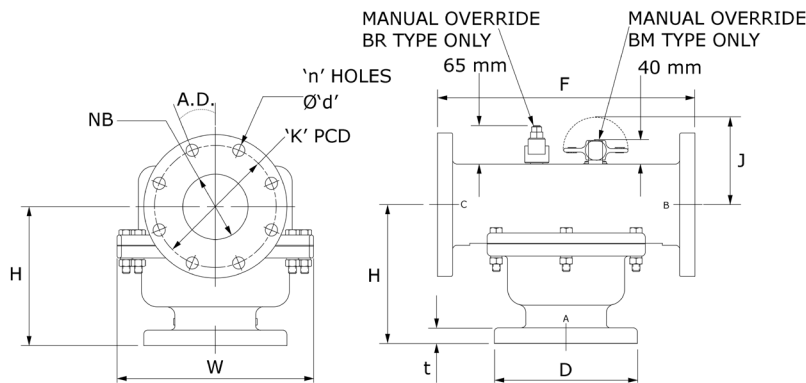

Dimensions - mm (inches)

Dimensions	Port connection (D)	Valve model							
		BG/BO	BH	BM	BC/BM/BR	BF	BFS/BFR	BG/BO	BH
		Nominal bore size - mm (inches)							
		40 (1 1/2")				50 (2")			
F		246 (9.69")	271.5 (10.69")	197 (7.76")	225 (8.88")	270 (10.63")	271.5 (10.69")	246 (9.69")	271.5 (10.69")
H		90.5 (3.58")	101.6 (4.00")	149.2 (5.87")	149.2 (5.88")	112.7 (4.44")	115.9 (4.56")	90.5 (3.58")	101.6 (4.00")
J		96.8 (3.81")	103.2 (4.06")	116 (4.56")	149.2 (5.88")	120.7 (4.75")	123.8 (4.88")	96.8 (3.81")	103.2 (4.06")
D		82.6 (3.25")	90.6 (3.56")	128.6 (5.06")	165 (6.50")	165 (6.50")	152.4 (6.00")	82.6 (3.25")	90.6 (3.56")
W		139.7 (5.50")	146.1 (5.75")	139.7 (5.50")	139.7 (5.50")	139.7 (5.50")	139.7 (5.50")	139.7 (5.50")	146.1 (5.75")
NB		-	-	41.3 (1.63")	54 (2.13")	54 (2.13")	54 (2.13")	-	-
t		-	-	14.3 (0.56")	20 (0.79")	20 (0.79")	15.9 (0.63")	-	-
K	A	-	-	-	110 (4.33")	125 (4.92")	-	-	-
	B	-	-	-	125 (4.92")	125 (4.92")	-	-	-
	F/J	-	-	98.4 (3.87")	120.6 (4.75")	120.6 (4.75")	120.6 (4.75")	-	-
Ød	A	-	-	-	14 (0.55")	14 (0.55")	-	-	-
	B	-	-	-	18 (0.71")	18 (0.71")	-	-	-
	F/J	-	-	15.9 (0.63")	19.05 (0.75")	19.05 (0.75")	19.05 (0.75")	-	-
n	A	-	-	-	4	4	-	-	-
	B	-	-	-	4	4	-	-	-
	F/J	-	-	4	4	4	4	-	-
A.D.	A	-	-	-	45°	45°	-	-	-
	B	-	-	-	45°	45°	-	-	-
	F/J	-	-	45°	45°	45°	45°	-	-

Thermostatic Control Valve - Model B

Valve Dimensions Continued

Note: Contact AMOT for detailed outline drawings when required.

2 1/2" - 6" BO/BM/BR

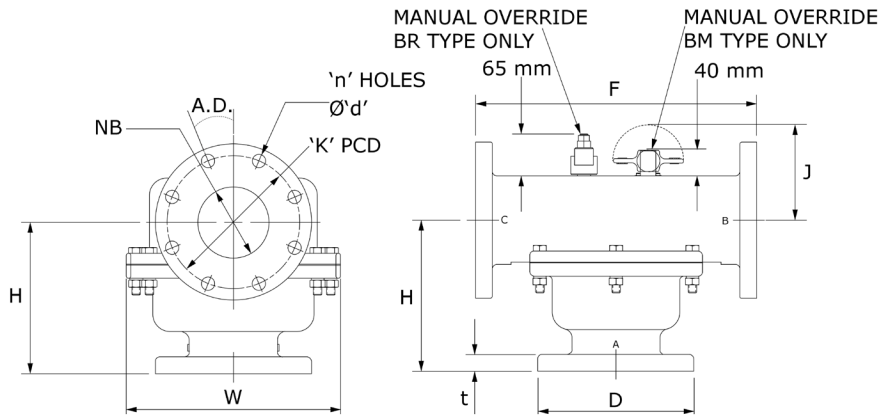

8" BO/BR

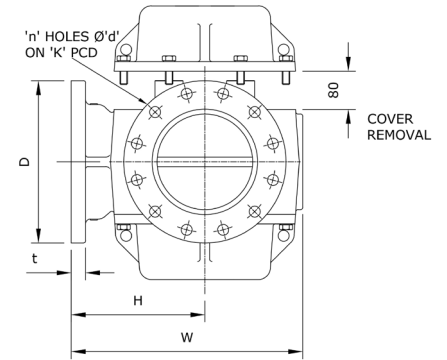

Dimensions - mm (inches)

Dimensions	Port connection (D)	Valve model						
		BO/BM/BR	BO/BM/BR	33 BO/BR	BO/BM/BR	BO/BM/BR	BO/BM/BR	BO/BR
		Nominal bore size - mm (inches)						
		65 (2 1/2")	80 (3")		100 (4")	125 (5")	150 (6")	200 (8")
F		254 (10.00")	267 (10.50")	267 (10.50")	403 (15.88")	489 (19.25")	489 (19.25")	840 (33.07")
H		163.5 (6.44")	169.8 (6.69")	170 (6.69")	215.9 (8.5")	239.7 (9.44")	252.44 (9.94")	280 (11.02")
J		141.3 (5.56")	141.3 (5.56")	141.3 (5.56")	130.2 (5.13")	127 (5.00") or 134 (5.28)#	114.5 (4.56") or 119.5 (4.70)#	315 (12.40") or 330.3 (13)#
D		185 (7.28")	200 (7.87")	200 (7.87")	224 (8.82")	254 (10.00")	285 (11.22")	340 (13.39")
W		209.6 (8.25")	209.6 (8.25")	245 (9.65")	308 (12.13")	349 (13.75")	482.6 (19.00") or 506.3 (19.93)#	485 (19.09") or 488 (19.21)#
NB		63.5 (2.50")	79.4 (3.13")	88 (3.47")	101.6 (4.00")	130.2 (5.13")	155.6 (6.13")	270 (10.63")
t		20 (0.79")	22 (0.87")	22 (0.87")	24 (0.95")	26 (1.02")	26 (1.02")	30 (1.18")
K	A	130 (5.12")	150 (5.91")	160 (6.30")	170 (6.69")	200 (7.87")	225 (8.86")	295 (11.61")
	B	145 (5.71")	160 (6.30")	160 (6.30")	180 (7.09")	210 (8.27")	240 (9.45")	295 (11.61")
	F/J	139.7 (5.50")	152.4 (6.00")	152.4 (6.00")	190.5 (7.50")	216 (8.50")	240 (9.45")	299 (11.77")
Ød	A	14 (0.55")	18 (0.71")	18 (0.71")	18 (0.71")	18 (0.71")	18 (0.71")	22 (0.87")
	B	18 (0.71")	18 (0.71")	18 (0.71")	18 (0.71")	18 (0.71")	23 (0.91")	22 (0.87")
	F/J	19.05 (0.75")	19.05 (0.75")	19.05 (0.75")	19.05 (0.75")	22.2 (0.87")	23 (0.91")	22 (0.87")
n	A	4	4	4	4	8	8	8
	B	4	8	8	8	8	8	8 or 12*
	F/J	4	4	4	8	8	8	8
A.D.	A	45°	45°	45°	45°	22.5°	22.5°	22.5°
	B	45°	22.5°	22.5°	22.5°	22.5°	22.5°	22.5° or 18°*
	F/J	45°	45°	45°	22.5°	22.5°	22.5°	22.5°

* 8 holes on PN10 Flange, 12 holes on PN16 Flange

Iron & bronze for first value; steel & stainless steel for second value

Thermostatic Control Valve - Model B

Maintenance and Service Parts

Over time, exposure to foreign chemicals and particulate matter as well as prolonged operation at extreme conditions may reduce the effectiveness of the valve. At such time, AMOT Thermostatic Valves can be restored to original performance by installing an AMOT thermostatic valve service kit or a seal kit and new temperature element(s).

Service kits are ONLY available for purchase from the Americas and Canada locations. If ordering from the Europe or Asia-PAC locations please purchase a seal kit and element to properly service your valve.

Service kits include all new thermostatic element(s), seals and gasket required for normal maintenance. Seal kits include new seals and gasket(s). Whenever element(s) are replaced, the seals and gasket(s) should also be replaced.

Ordering from Americas and Canada Service kits

Service kits are ONLY available for purchase from the Americas and Canada locations.

Service kits are available with element(s), seals and gasket required to service the valve. Order service kits using the AMOT valve part number and nominal temperature setting. Refer to the AMOT valve part number that is printed on the valve nameplate and the AMOT valve part number structure on page 8. The nominal temperature setting is also stamped onto the element flange.

Service kit model number structure

- 1) Replace Body material (C) and Port connection (D) with "KIT-".
- 2) If Special (J) is not blank, please contact the facility.

Ordering from Europe and Asia-PAC Seal kits

Seal kits are available with seals and gasket(s) only. Order seal kits using the seal kit model number which is identified by the valve size and element/seal material code from the AMOT valve part number. Refer to the AMOT valve part number that is printed on the valve nameplate and the AMOT valve part number structure on page 8.

AMOT recommends fully servicing thermostatic control valves with each regularly scheduled major overhaul of the turbine, engine, compressor or other associated equipment. AMOT recommends a service interval of not more than 24 months to ensure optimum valve performance.

AMOT designs and tests all its products to ensure that high quality standards are met. For good product life, carefully follow AMOT's installation and maintenance instructions; failure to do so could result in damage to the equipment being protected or controlled.

Thermostatic service kits may also be used for adapting valves to new service temperatures. Please request a new nameplate when adapting valves to a new service temperature by contacting the facility.

AMOT does NOT offer service kits for 8BO or 8BR Model B Thermostatic Valves. In order to properly service an 8BO and/or 8BR valve please purchase an element and seal kit. Refer to the ordering instructions on page 12.

Example valve part number							
A	B	C	D	E	F	G	J
1 1/2	BO	B	T	095	01	D	
Example service kit model number							
A	B	C	D	E	F	G	J
1 1/2	BO	KIT-		095	01	D	

A - Valve size D - Port connection G - Leakhole size
B - Valve model E - Control temperature (°F) J - Special
C - Body material F - Element and seal material

Element(s)

Order temperature elements using the element part number which is identified by the element/seal material code and nominal temperature setting from the AMOT valve part number. Refer to the AMOT valve part number that is printed on the valve nameplate and the AMOT valve part number structure on page 8.

Thermostatic Control Valve - Model B

Maintenance and Service Parts Continued

Ordering from Europe and Asia-PAC continued

Seal kit model number structure

- 1) Identify the valve size and body material codes, located in the Valve size (A) and Body material (C) sections in the AMOT valve part number, respectively. Locate those values in Table 1 to identify the valve size code.
- 2) Identify the element/seal material code, located in the Element and seal material (F) section of the AMOT valve part number. Locate that value in Table 2 to identify the seal code.
- 3) Place first the valve size code then the seal code after the basic part number to complete the seal kit model number, as shown in Table 3.

Valve size code	Valve size (A)	Body material (C)
15	1 ½	ALL
20	2	ALL
25	2 ½	ALL
30	3	ALL
33	33 ¹	ALL
40	4 ²	B/C/D
41	4 ³	R/S
50	5 ²	B/C/D
51	5 ³	R/S
60	6 ²	B/C/D
61	6 ³	R/S
80	8 ²	B/C/D
81	8 ³	R/S

Seal code	Element/seal material (F) ⁴
1	01, 05, 11
2	02, 03, 20
3	44, 45
4	07, 09
5	08, 53

	Basic part no.	Valve size code (Table 1)	Seal code (Table 2)
	46342X	15, 20, 25, 30, 33, 40, 41, 50, 51 60, 61, 80, 81	1, 2, 3, 4, 5
Examples			
Valve part number	Seal kit model number		
4BORJ15001-D4-AA	46342X	41	1
8BRCF09007-00-AA	46342X	80	4

Element part number structure

- 1) Identify the element/seal material code, located in the Element and seal material (F) section of the AMOT valve part number.
- 2) Identify the temperature, located in the Control temperature °F (E) section of the AMOT valve part number.
- 3) Use those 2 codes to identify the element part number, as shown in Table 4.

Temperature °F (E)										Element/seal material (F) ⁴			Element part number			Qty.
055-240										01, 03, 44			1096X(Temp.)			Refer to the Comments on the Valve size (A) section of the How to Order table on page 8.
										02, 45			1096P(Temp.)			
										07, 53			2433X(Temp.)			
										08			2433P(Temp.)			
										11, 20			5566X(Temp.)			
										05			6836S(Temp.)			
										09			6938S(Temp.)			
Examples										Valve part number			Element part number			Qty.
4	BO	R	J	150			01			-D	4	-AA	1096X150			4
8	BR	C	F	090			07			-0	0	-AA	2433X090			16

NOTES:

- ¹ 3" valve with 3 elements.
- ² All body materials except Steel, and stainless steel.
- ³ Steel, and stainless steel body materials ONLY.
- ⁴ If your element/seal material code does not correspond with the given values, please contact the facility to confirm your element/seal material code.

Thermostatic Control Valve - Model B

Maintenance and Service Parts Continued

Service parts (refer to diagrams below and on page 14)

Service kit parts										
Ref no.	Valve size (inches)									Description
	1 1/2	2	2 1/2	3	3 ¹	4	5	6	8	
	Qty.									
7	1	1	2	2	3	4	6	9		Element seal
8	1	1	2	2	3	4	6	9		Element
9	1	1	2	2	3	4	6	9		Housing seal
9	-	-	-	-	1	1	1	1		Housing gasket
17	1	1	2	2	3	4	6	9		Stem seal

Seal kit parts											
Ref no.	Valve size (inches)										Description
	1 1/2	2	2 1/2	3	3 ¹	4	5	6	8		
	Qty.										
6	-	-	-	-	-	-	-	-	-	4	Port seal
7	1	1	2	2	3	4	6	9	16		Element seal
9	1	1	2	2	3	4	6	9	16		Housing seal
9	1	1	1	1	1	1	1	1	2		Housing gasket
17	1	1	2	2	3	4	6	9	16		Stem seal

NOTES:

¹ 3" valve with 3 elements.

2" BC

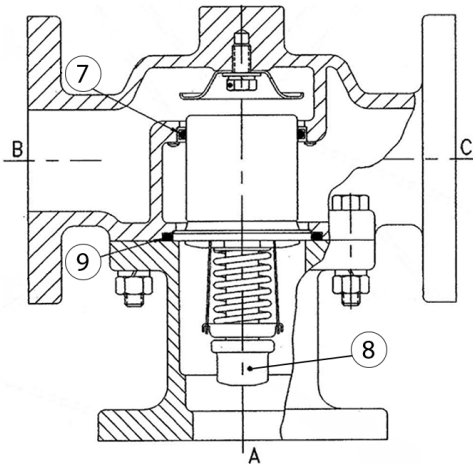

1 1/2" & 2" BM

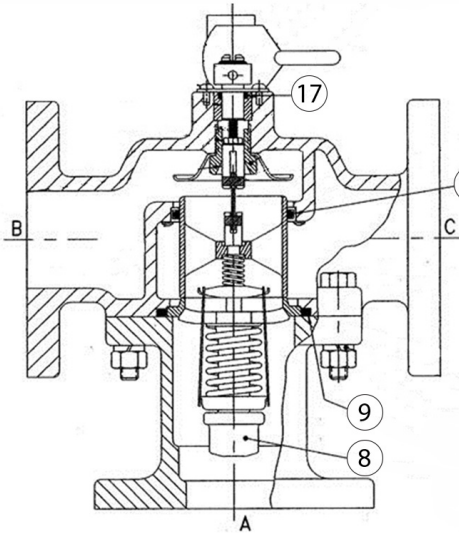

1 1/2" & 2" BR

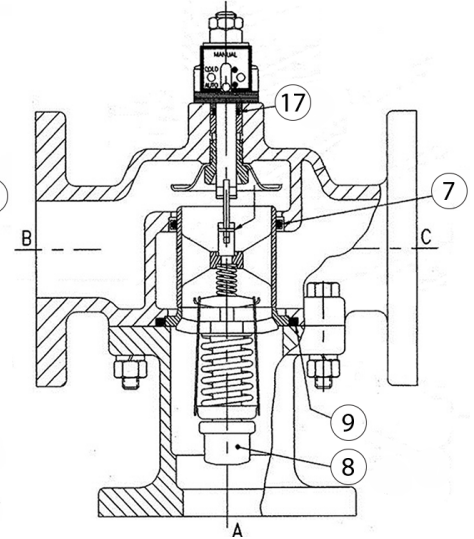

**2" BF
1 1/2" & 2" BG, BH, BO**

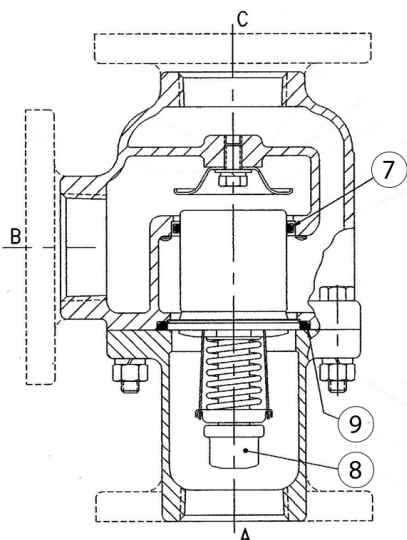

2 1/2" - 6" BM

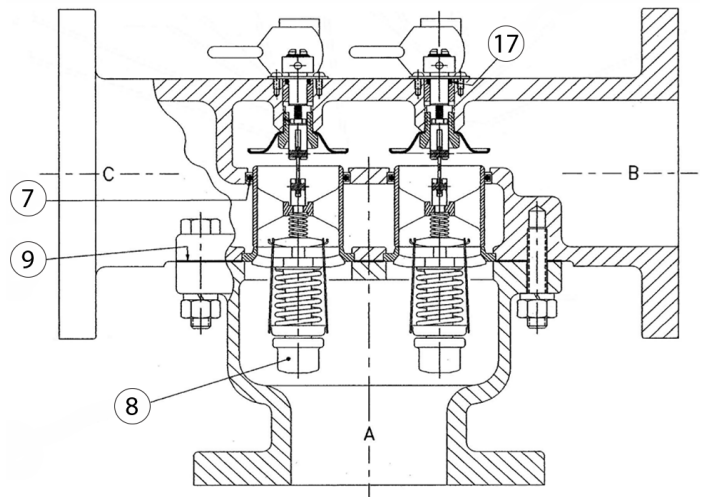

Thermostatic Control Valve - Model B

Maintenance and Service Parts Continued

Service parts continued

**2 1/2" - 6" BO
(except for 5B/6B Steel & SS)**

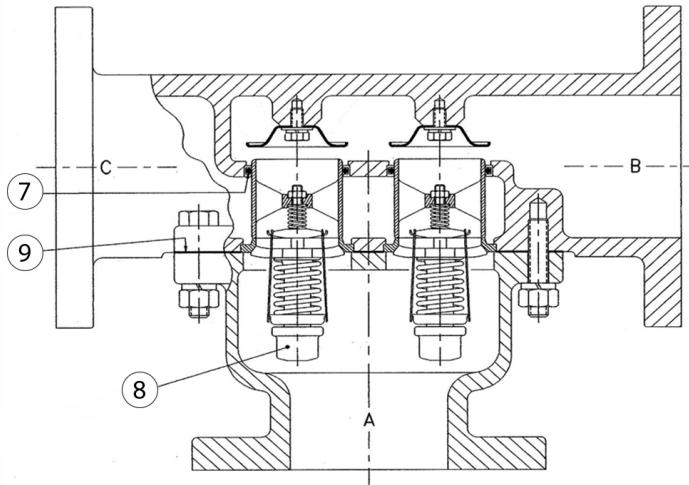

2 1/2" - 6" BR

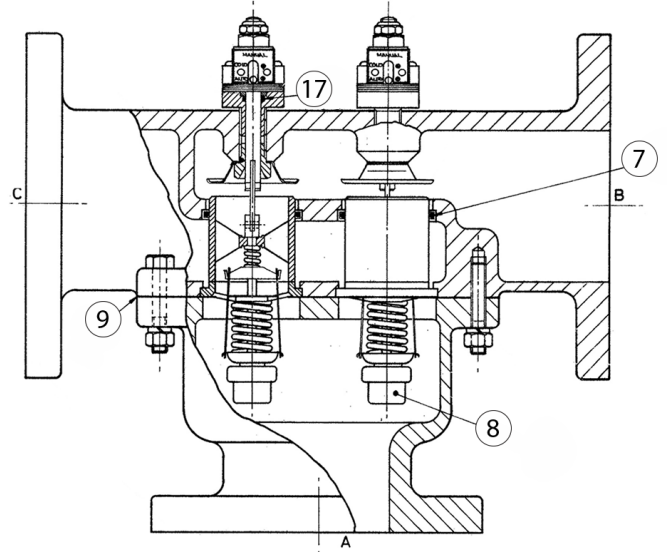

8" BO (all other material)/8BR

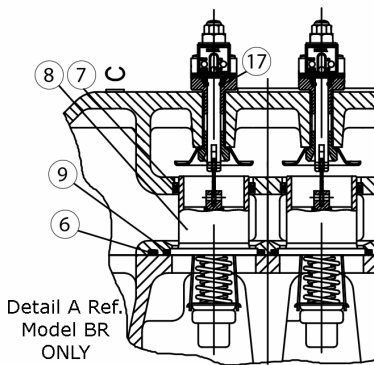

5", 6", 8" BO (steel & ss)

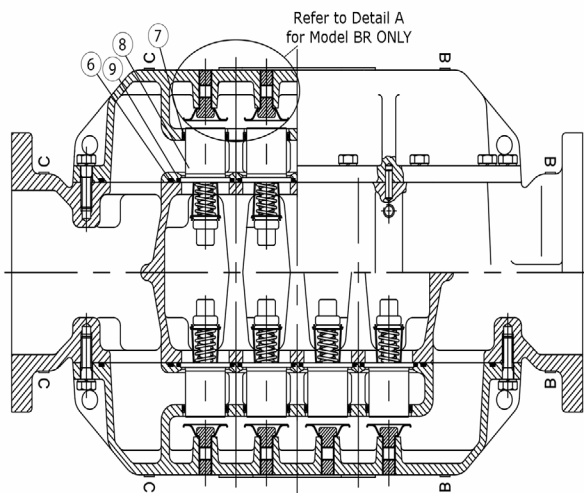
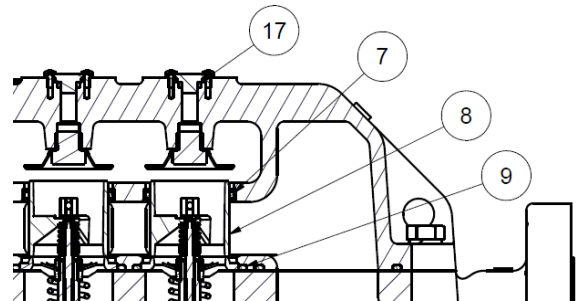

8" BM (steel & ss)

