

Panel & Line Regulators

VSR-1EL & VSR-1ELP Series

VIGOUR

Product Features

- Line mounting pressure regulator
- Brass chrome plated body and bonnet for inert, reactive, flammable and oxidizing gas and mixtures up to grade 6.0
- Stainless steel 316L body and bonnet for corrosive gases
- 4 ports flexible configuration
- Stable outlet pressure
- Simple outlet pressure limitation by handwheel
- Tested for use with oxygen



Typical Applications

- Component Testing
- Calibration Systems
- Laboratory Pressure Control
- High Pressure Sampling Systems
- Service & Test Equipment

VSR-1EL



VSR-1ELP



Mounting panel
Model No. : VSR-T-BPB

Dimensions (mm)

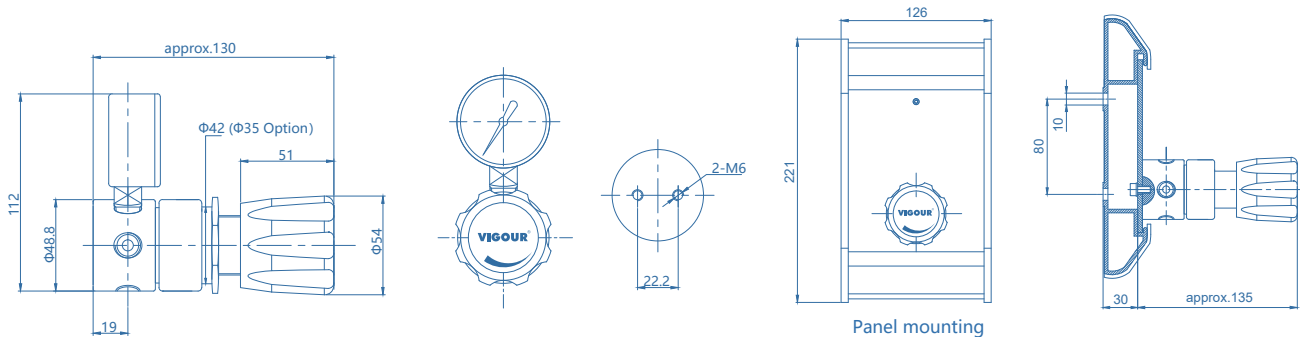

Technical Data

Type:	single-stage
Inlet pressure P ₁ :	max. 100bar
Outlet pressure P ₂ :	VAC/2/4/8/10/20 bar
Materials	
Body regulator:	see ordering info
Valve seat:	PCTFE
Diaphragm:	Hastelloy® C276
Filter:	SS 316L
Inlets and Outlets:	1/4" NPT(F)
Temperature range:	-30°C to +74°C
Leak rate: (to atmosphere)	1x10 ⁻⁸ mbar l/s He
(Via seat)	1x10 ⁻⁶ mbar l/s He
Flow capacity:	Cv=0.18
Weight:	1.04kg

Flow Chart

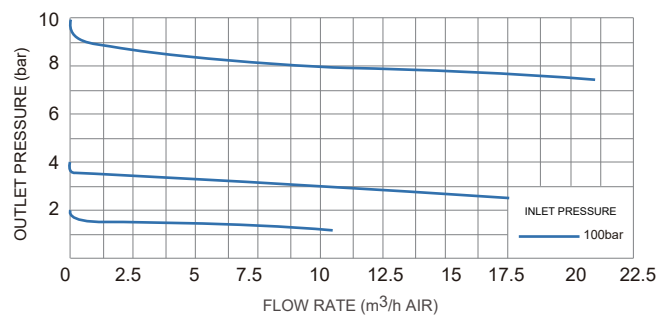

Ordering Information

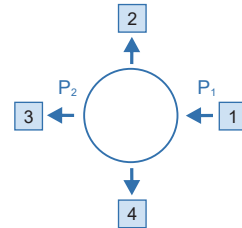

Inlets / Outlets

F4: 1/4" NPT(F)	02: 1/8" Tube fitting	8M: 8mm Tube fitting	B: Plug
M4: 1/4" NPT(M)	04: 1/4" Tube fitting	TW6M: 6mm Weld tube	
F6: 3/8" NPT(F)	06: 3/8" Tube fitting	TW8M: 8mm Weld tube	
M6: 3/8" NPT(M)	6M: 6mm Tube fitting	P: Gauge (Psig/bar)	

* Other connection standard, consult factory.

Port Selection

VSR - 1EL S - 100 - 20 - 1 - 2 - 3 - 4 - N2

Type

L: Line
LP: Panel

Body Material

S: 316L
C: Chrome Plated Brass

Inlet Pressure P₁

40: 40 bar
100: 100 bar

Type of Gas

Please specify type of gas

Outlet Pressure P₂

2: to 2 bar
4: to 4 bar
8: to 8 bar
10: to 10 bar
20: to 20 bar
V2: -1bar to 2bar
V4: -1bar to 4bar
V10: -1bar to 10bar
V20: -1bar to 20bar

Ordering Example

Example: VSR - 1EL C - 100 - 20 - F4 - P - F4 - B - O2

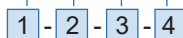

* For mixed gases please specify cylinder connection standard and thread when ordering.