



KP350 STANDARD TWIN PACKAGED BLOWER

STANDARD FEATURES

- 160 CFM Capacity
- Attractive 19-inch [482.6mm] stainless steel grilles
- Exhaust guards included
- Filter
- Heavy-gauge steel shell with EIA-notched flanges and baked powder finish
- Inlet air cools motor for longer life
- Three foot [0.9m] (minimum) 3-wire power cord
- Twin blower design for maximum airflow
- UL/CSA ball-bearing motors

PERFORMANCE GRAPH

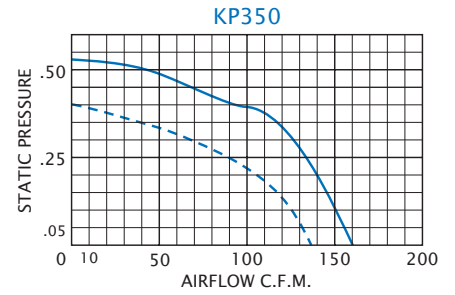

Airflow vs. static pressure curves are shown for 60 Hz (solid line) and 50 Hz (broken line) inputs. Static pressure is in inches of water.



ACCESSORIES AND OPTIONS

- Adapters
- Airflow Switch
- Automatic Speed Control
- EMI/RFI Shielding
- Filter Recoating Adhesive
- Grille Assemblies for replacement
- Other voltages and frequencies
- Replacement Filters
- Special external paint finishes
- Special line cord or connectors



TECHNICAL DATA*

Model	Volts	CFM @ 0" S.P.	Cutoff S.P.	RPM Nominal	Amps		Watts	Approximate Weight	
					Run.	L.R.		Lbs.	Kg.
KP350A	115	160	0.52	1500	1.2	1.6	90	18	8.2
KP350B	115	160	0.52	1500	1.2	1.6	90	18	8.2

*115V, 60 Hz. operation. Unavailable in 230 VAC.

DIMENSIONS AND DISCHARGE LOCATIONS inches [metric]

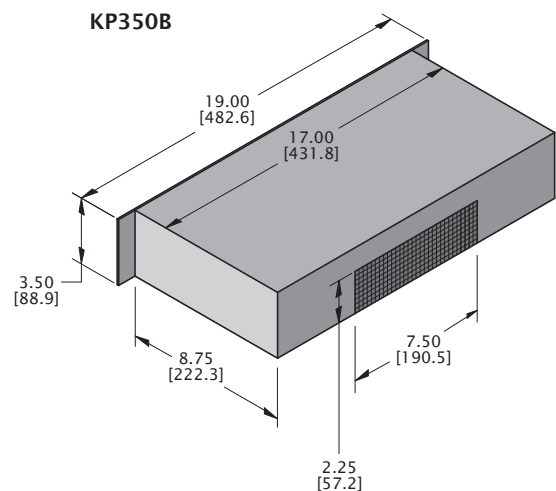
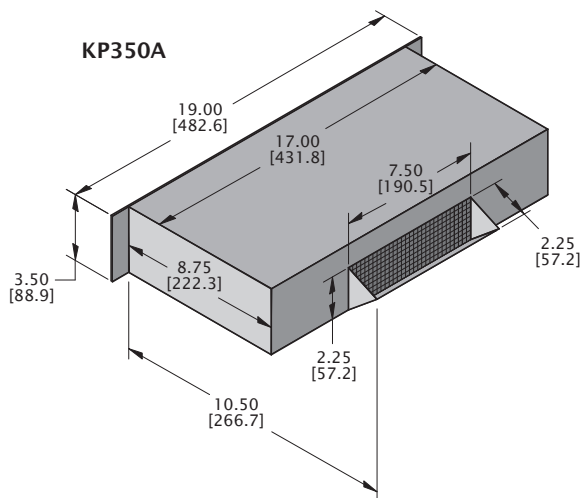

HOW TO ORDER

Specify model number, adding discharge suffix A, or B. Example: KP350A. Unavailable in 230 VAC.

Dimensions, inches [mm], are for reference only and subject to change.

kp350.qxd (8/1/23) (CDR: 20498)

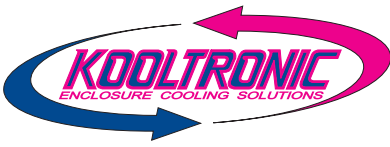

KP350 STANDARD TWIN PACKAGED BLOWER

DESCRIPTION

Standard Twin Packaged Blowers are the most popular KOOLTRONIC Packaged Blower. These blowers achieve exceptional performance through use of the largest possible blower housings and wheels. Each **KP350 Standard Twin Packaged Blower** contains a twin blower design powered by two precision ball-bearing motors.

These widely-used **Standard Twin Packaged Blowers** deliver air from more than 50% of their 17" [431.8mm] width, while conventional blowers deliver air from only about 30%.

Internal neoprene isolation mounts reduce transmission of vibration and AC hum to the enclosure. Long service life and trouble-free performance are assured through the use of precision ball-bearing motors in all models and by the dual inlet quadruplex design, which uses intake air to cool the motor.

STANDARD FEATURES

RUGGED CONSTRUCTION: Precision-engineered heavy-gauge steel construction insures blower will stand up under tough industrial applications. EIA-notched flanges extend 17" [431.8mm] blower cabinet to 19" [482.6mm] panel width.

BAKED POWDER FINISH: Durable, baked-on gray powder finish is standard. Other finishes are available.

PRECISION BALL-BEARING MOTORS: All motors, whether permanent split capacitor or shaded pole, are UL/CSA Recognized, and include automatic-reset thermal overload protection. Designed for low temperature rise, KOOLTRONIC motors are also cooled by the blowers' intake air, for maximum motor life. All motors meet Federal Specification CC-M-1807A, and include double-sealed or double-shielded precision ball bearings which meet Federal Specification FF-B-171A. Special permanent lubricants perform over a broad temperature range: -20°F (-28.9°C) to 250°F (121.1°C). Consult KOOLTRONIC for motors designed to meet military or extreme environmental specifications.

POWER: 115 VAC 50/60 Hz. Unavailable in 230 VAC.

GRILLE: All units include attractive 19" [482.6mm] wide stainless steel grilles with knurled captive fasteners for easy removal. Grille area is 65% open and complies with OSHA and UL safety standards.

FILTERS: The filters included with all packaged blowers consist of a multi-layer grid of sturdy, corrugated aluminum in a one-piece aluminum frame. Adhesive coated to trap particulate matter, they are easy to remove, wash and treat with KOOLTRONIC A-16, an adhesive-rejuvenating spray. Filters must be kept free of accumulations, to prevent reduction or loss of performance and/or damage to equipment.

POWER CORD: All 115 VAC, 50/60 Hz units are supplied with a minimum of 36 " [914.4mm] three-wire cord with molded plug included, internally grounded and securely locked to the case by a strain relief bushing. Special lengths and/or plugs are available.

EXHAUST GUARDS: Included on all packaged blowers.

ACCESSORIES AND OPTIONS*

ADAPTERS: (Set of two) These extend the width of any 19" [482.6mm] KOOLTRONIC Packaged Blower to permit mounting in a cabinet designed for 24" [609.6mm] units. The EIA-notched adapters are covered by a plate of mirror-finish stainless steel to match KOOLTRONIC Standard Grilles. These adapters are non-structural. Therefore, Packaged Blowers must be supported at the rear, due to their weight.

Models

Mirror Finish	Height Inches [metric]
KA24-3M	3.50 [88.9]

AIRFLOW SWITCH: Protects equipment against damage caused by loss of cooling airflow by activating an alarm or turning off power. The switch can be mounted on any suitable surface which allows the stainless steel air vane to be placed in the critical airstream. This switch is a single-pole double-throw type, with normally open and normally closed contacts. To order integrated airflow switch add -XX10 to model number. To order as external accessory, see Kooltronic website.

AUTOMATIC SPEED CONTROL: The Kooltronic Fan and Blower Automatic Speed Control (Part Number KSC100) is a solid state "smart" controller packaged in a NEMA 1 type enclosure for remote mounting. The allowable input power supply range is 95 to 250 Volts, 47 to 63 Hz. It is furnished standard with an IEC 320 connector, a power supply fuse and a temperature sensor. Additional temperature sensors are optional. Power cord is not provided.

The controller will operate single or multiple fans or blowers of compatible voltage and frequency up to a combined load of 6 Amps. The controller may be operated by either a control voltage signal of 0 to 10 VDC, a control current signal of 0 to 20 mA or one to three temperature sensors. With multiple temperature sensors the controller will respond to the highest sensed temperature.

The control circuit board is furnished with a terminal strip for field connecting the sensor and fan wires. A pressure type strain relief connector is furnished in the enclosure. If required by installation or by code, this connector can be replaced with a 1/2-inch [12.7mm] trade size conduit connector.

A wide variety of control logic options can be field programmed into the controller by means of a board mounted DIP switch. These include fan idle or starting speed at 30%, 40%, 50% or 60% of supply voltage, fan on or off below the idle setting, control temperature setting at 86°F (30°C), 95°F (35°C), 104°F (40°C), 113°F (45°C), and temperature differential settings of 7°F (4°C) and 18°F (10°C). The selectable fan on/off feature is operative when the temperature(s) drop below the control temperature setting.

Consult factory for use with compatible Kooltronic fans or blowers.

*Contact KOOLTRONIC for information.

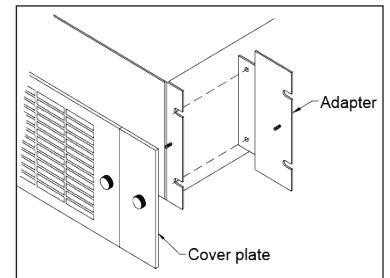

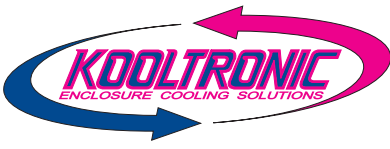

KP350 STANDARD TWIN PACKAGED BLOWER

ACCESSORIES AND OPTIONS* (continued)

EMI/RFI SHIELDING: See EMI/RFI-Shielded Twin Packaged Blowers.

FILTER RECOATING ADHESIVE: This compound is a superior product for recoating filters after washing. The adhesives penetrate dirt layers to keep the filter surface tacky for longer effective performance between washings. Part No. A-16.

FILTERS FOR REPLACEMENT: All KOOLTRONIC filters consist of a multi-layer grid of sturdy corrugated aluminum, securely held in a one-piece aluminum frame. Filters are required wherever air is drawn into an electronics enclosure or related cooling equipment to keep internal parts as clean as possible.

A non-drying adhesive coating traps a high percentage of particulate matter. These filters are reuseable, they may be washed and recoated with the appropriate filter recoating adhesive. Replacements are available for those which become damaged or otherwise non-serviceable.

Part No. 3501F (16.63" x 3.13" x 0.50" [422.3mm x 79.5mm x 12.7mm])

GRILLE ASSEMBLIES: These assemblies are ideal for venting applications on the enclosure. These attractive grilles are made of mirror-finish stainless steel. All are 19" [482.6mm] wide. They are 65% open, comply with OSHA and UL safety standards, and include knurled captive fasteners for easy attachment and removal.

Model

Grilles Assemblies	Filter Grilles Assemblies	Height Inches [metric]
3501X	FG350-19	3.50 [88.9]
Overall depth, including fasteners:		
0.50" [12.7mm]	0.75" [19.1mm]	

*Contact KOOLTRONIC for information.

OTHER VOLTAGES AND FREQUENCIES

SPECIAL EXTERNAL PAINT FINISHES

SPECIAL LINE CORD OR CONNECTORS

*Contact KOOLTRONIC for information.

KOOLTRONIC also designs and manufactures a variety of Packaged Blowers to meet *unique* specifications. We invite your inquiries about our modification and custom-design capabilities.