

Ring Torsion Load Cell

FEATURES

- Capacity range: 250 kg to 60 t
- Low profile, stainless steel construction
- Hermetically sealed, IP66 and IP68; IP69K is available for 250 kg, 5 t and 10 t versions
- Meets OIML R-60 and NTEP 6000d
- Outputs are matched to ensure easy and accurate parallel connection of multiple load cells
- **Optional**
 - ATEX certified versions are available for use in potentially explosive atmospheres
 - Multi-interval and multiple-range versions are available



APPLICATIONS

- Platform scales
- Belt scales
- Silo hopper weighing

DESCRIPTION

The RLC is a low profile, high performance stainless steel ring torsion type load cell.

The fully welded construction and glass-to-metal cable-entry ensure that this product can be used successfully in harsh environments found in the food, chemical and allied process industries.

This product is suitable for small and medium platform scales, hoppers and process weighing.

This product meets the stringent Weights and Measures requirements throughout Europe and USA.

OUTLINE DIMENSIONS in millimeters

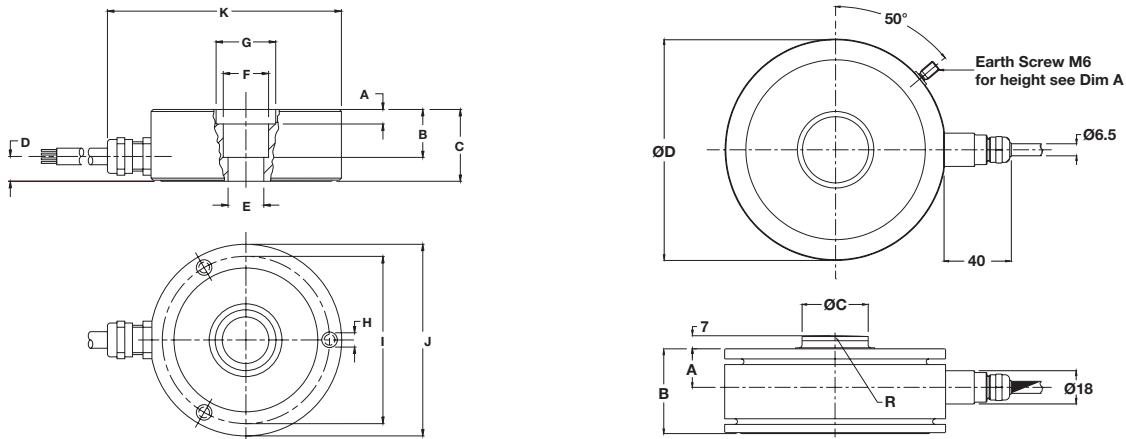

CAPACITY (t)	0.25, 0.5, 1	2, 3.5, 5	10		CAPACITY (t)	28	60
A	1.0	6.0	-	Cable specifications Cable length: 3 m for 0.25–1 t, 5 m for 3–10 t, 10m for 28 t, 15 m for 60 t Excitation + Pink Excitation – Grey Output + Brown Output – White Cable screen is connected to load cell body. For capacities 28 and 60 ton cable screen is not connected to body.	A	21	28
B	15.0	20.0	14.8		B	46	62
C	25.0	30.0	35.0		C	35.9	47.9
D	9.5	8.5	10.0		D	120	140
E	M10	15 H7	Ø24.9		R	400	600
F	Ø19	Ø19	Ø29.1				
G	Ø25	Ø25					
H	M6 (3X120°) 8 Deep						
I	Ø70	Ø70	Ø83				
J	Ø80	Ø80	Ø95				
K	97.5	97.5	112.5				

Ring Torsion Load Cell

SPECIFICATIONS					
PARAMETER	VALUE				UNIT
Standard capacities (E _{max})	0.25, 0.5, 1, 2, 3.5, 5, 10, 28, 60				t
Accuracy class according to OIML	NTEP III L	D3	C3 ⁽³⁾	C6 ⁽²⁾	
Maximum no. of verification intervals (n _{ic})	10000		3000	6000	
Minimum verification interval			E _{max} /10000	E _{max} /15000	
Minimum verification interval type MR			E _{max} /20000 ⁽¹⁾	E _{max} /28000	
Rated output (=S)	2 (1.75 for 0.25 t, 2.05 for 10 t)				mV/V
Output accuracy for multiple LC systems	0.01				±% mV/V
Zero balance	1.0				±% FSO
Combined error	0.0200	0.0300	0.0230	0.0115	±% FSO
Creep error (30 minutes)			0.0245	0.0123	±% FSO
Temperature effect on zero	(0.0010)	(0.0010)	0.0070	0.0045	±% FSO/5°C (°F)
Temperature effect on sensitivity (output)	(0.0008)	(0.0008)	0.0050	0.0025	±% FSO/5°C (°F)
Minimum dead load	0				% E _{max}
Maximum safe overload	150				% E _{max}
Ultimate overload	300				% E _{max}
Maximum safe side load	100% up to 10 t 50% for 28 & 60 t				% E _{max}
Deflection at E _{max}	0.12–0.20				mm
Excitation voltage	5 to 15				V
Maximum excitation voltage	30				V
Input resistance	1110±50 (1100±50 for 0.25 t and 10 t) 1075±100 for 28 t 1350±100 for 60 t				Ω
Output resistance	1025±25 (1025±50 for 0.25 t and 10 t) 930±0.5 for 28 t 1175±0.5 for 60 t				Ω
Insulation resistance	≥5000 (20 for 28 and 60 t)				MΩ
Compensated temperature range	-10 to +40				°C
Operating temperature range	-30 to +70				°C
Storage temperature range	-50 to +80				°C
Element material (DIN)	Stainless steel 1.4542				
Sealing (DIN 40.050 / EN60.529)	IP66 and IP68; IP69K available for 250 kg, 5 t and 10 t				
Recommended torque on fixation bolts	12 to 14				N*m
ATEX opt. for potent. explosive atmospheres	II2G EEx ib IIC T4/T6, II2D, IIID T70 II3G nA II T4/T6				

⁽¹⁾ Capacities of 28 and 60 ton E_{max}/15,000 approved to OIML C3 only

⁽²⁾ 250 kg and 10 t capacities are approved to OIML C3 only. Maximum application range for 0.5 t is 0.75*E_{max}.

⁽³⁾ The following accuracy classes are available (from 0.5 t to 10 t): C3MI6 and C3MI7.5. Minimum dead load output return is ½ E_{max}/6000 and ½ E_{max} /7500 respectively

FSO— Full Scale Output

All specifications subject to change without notice.



Disclaimer

ALL PRODUCTS, PRODUCT SPECIFICATIONS AND DATA ARE SUBJECT TO CHANGE WITHOUT NOTICE.

Vishay Precision Group, Inc., its affiliates, agents, and employees, and all persons acting on its or their behalf (collectively, "VPG"), disclaim any and all liability for any errors, inaccuracies or incompleteness contained herein or in any other disclosure relating to any product.

The product specifications do not expand or otherwise modify VPG's terms and conditions of purchase, including but not limited to, the warranty expressed therein.

VPG makes no warranty, representation or guarantee other than as set forth in the terms and conditions of purchase. **To the maximum extent permitted by applicable law, VPG disclaims (i) any and all liability arising out of the application or use of any product, (ii) any and all liability, including without limitation special, consequential or incidental damages, and (iii) any and all implied warranties, including warranties of fitness for particular purpose, non-infringement and merchantability.**

Information provided in datasheets and/or specifications may vary from actual results in different applications and performance may vary over time. Statements regarding the suitability of products for certain types of applications are based on VPG's knowledge of typical requirements that are often placed on VPG products. It is the customer's responsibility to validate that a particular product with the properties described in the product specification is suitable for use in a particular application. You should ensure you have the current version of the relevant information by contacting VPG prior to performing installation or use of the product, such as on our website

No license, express, implied, or otherwise, to any intellectual property rights is granted by this document, or by any conduct of VPG.

The products shown herein are not designed for use in life-saving or life-sustaining applications unless otherwise expressly indicated. Customers using or selling VPG products not expressly indicated for use in such applications do so entirely at their own risk and agree to fully indemnify VPG for any damages arising or resulting from such use or sale. Please contact authorized VPG personnel to obtain written terms and conditions regarding products designed for such applications.

Product names and markings noted herein may be trademarks of their respective owners.

Copyright Vishay Precision Group, Inc., 2014. All rights reserved.
