

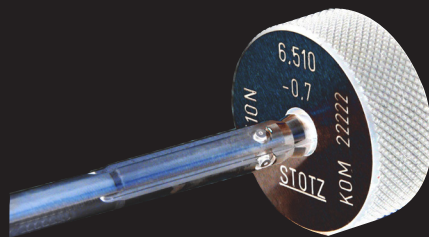

Pneumatic Electronic Transducer PEW



PEW

# PEW

## description

The Pneumatic Electronic Transducer PEW is used in connection with pneumatic measuring tools to evaluate longitude changes in micrometer ranges.

The PEW produces an analog electric output signal proportional to the longitude change. The signal can be displayed on various devices or be used to control processing machines.

The PEW contains no moving parts and is therefore free of wear. It has the distinction of high precise measuring for quick measurements, a negligible small hysteresis and small dimensions.

The setting time of the PEW is only 250 ms.

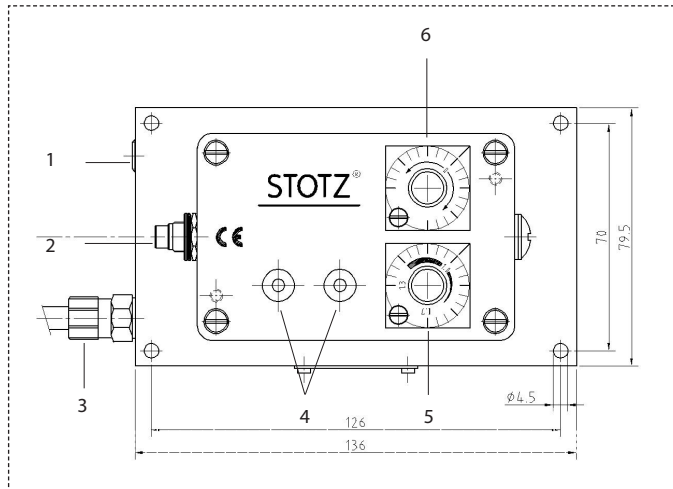
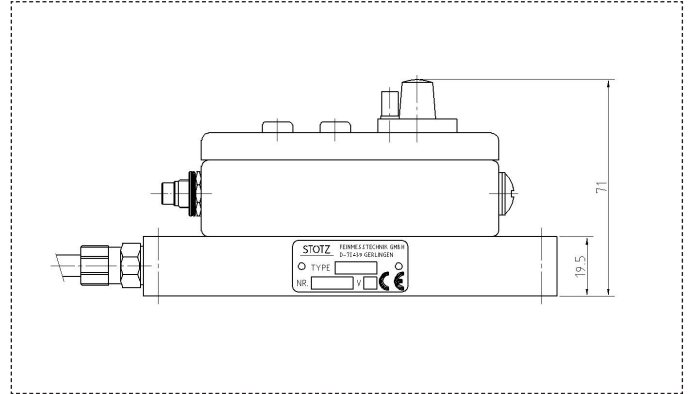

position	description
1	connector for pneumatic measuring tool
2	plug 5-points
3	connector for compressed air
4	jack for additional measuring data output
5	sensitivity correction
6	zero correction

## operating mode

With the pneumatic measurement tool (e.g. an air mandrel) connected to the PEW an air pressure proportional to the longitude that has to be measured (e.g. a bore diameter) will be established at the measuring point. This air pressure will be captured by a pressure sensor and converted into a voltage output proportional to the longitude.

A second pressure sensor monitors the fluctuations of the compressed air supply and readjust correlatively the voltage output.

## application area

The PEW is employed mainly for static or manual measurements. Its specific electronic guaranties a quick conversion into an output voltage of  $\pm 10V$  which can be displayed via a Multifunctional Measuring and Control Device (MSG) or a Computer.

## example of use

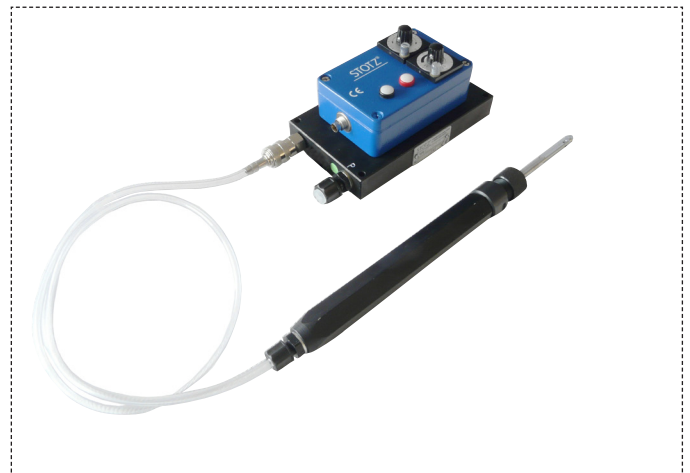

## technical data PEW

device characteristics	
power supply	24 V DC / 24 VAC / 50 Hz
power input	1 VA
voltage output	±10 V (±15 V FSC)
linearity	≤ 0,5% of measuring range
operating area	18...36 V DC
measuring data output	short-circuit-proof
power output	max. 5 mA
pressure	3,0 ± 0,1 bar
air consumption	aprox. 2 m <sup>3</sup> /h with free blow out
requirements	oil free, filtered
setting time	250 ms
transformation	100 mV/μm
Ingress Protection	IP 65
temperature	5...60°C (ambient temperature limit)
dimensions	3,13 x 2,8 x 5,35 inch / 79,5 x 71 x 136 mm

## plug configuration (plug 5-points)

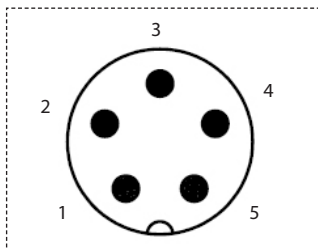

position	cable color	description
1	brown	measuring signal- (black jack)
2		connected with the box
3	green	measuring signal + (red jack)
4	white	24V input
5	yellow	24V input

## measuring principle

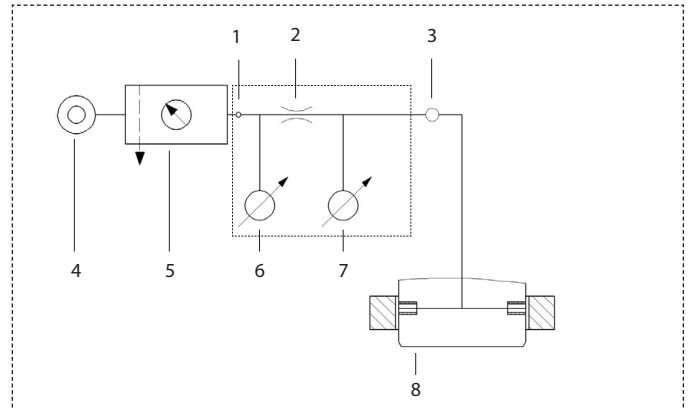

position	description
1	input compressed air
2	nozzle
3	connector for measuring tool
4	compressed air source
5	service unit for compressed air
6	sensor 1
7	sensor 2
8	measuring tool

## network

