

DL05/06 I/O Option Modules

16-point DC input module

D0-16ND3 Input Specifications	
Number of Inputs	16 (sink/source)
Input Voltage Range	20–28 VDC
Peak Voltage	30.0 VDC
Input Current	Typical: 4.0 mA @ 24VDC
Maximum Input Current	6mA @ 28VDC
Input Impedance	4.7 k Ω @ 24VDC
On Voltage Level	> 19.0 VDC
Off Voltage Level	< 7.0 VDC
Minimum ON Current	3.5 mA
Minimum OFF Current	1.5 mA
Off to On Response	2-8 ms, Typ. 4ms
On to Off Response	2-8 ms, Typ. 4ms
Status Indicators	Module activity: one green LED
Commons	4 (4pts/common) isolated
Fuse	No fuse
Connector Type	24-pin Molex 43025-2400 (See ZIPLinks for wiring options)
Base Power Required	Typical. 35mA (all pts. ON)

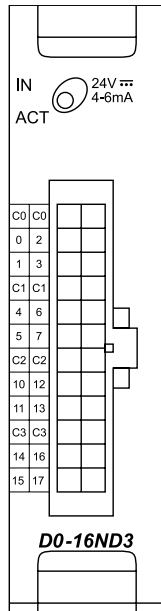

Equivalent input circuit

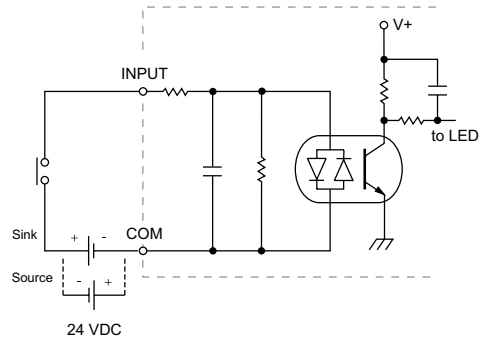

Derating chart

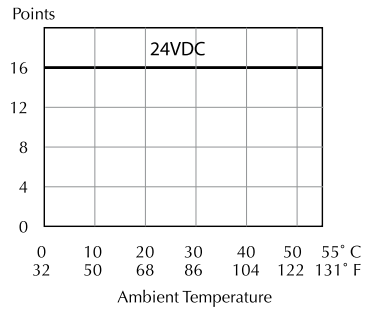

See Wiring Solutions for part numbers of ZIPLink cables and connection modules compatible with this I/O module.

Typical Wiring Example

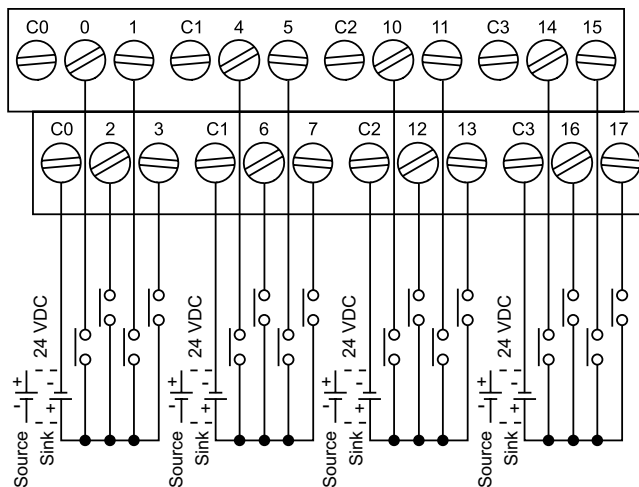

For "Sinking and Sourcing Concepts", see the Appendix section in this catalog.

Wiring Solutions using the **ZIPLink** Wiring System

ZIPLinks eliminate the normally tedious process of wiring between devices by utilizing prewired cables and DIN rail mount connector modules. It's as simple as plugging in a cable connector at either end or terminating wires at only one end. Prewired cables keep installation clean and efficient, using half the space at a fraction of the cost of standard terminal blocks. There are several wiring solutions available when using the **ZIPLink** System ranging from

Solution 1: DirectLOGIC I/O Modules to ZIPLink Connector Modules

When looking for quick and easy I/O-to-field termination, a **ZIPLink** connector module used in conjunction with a prewired **ZIPLink** cable, consisting of an I/O terminal block at one end and a multi-pin connector at the other end, is the best solution.



PLC I/O-to-**ZIPLink** Connector Modules that are ready for field termination, options for connecting to third party devices, GS, DuraPulse and SureServo Drives, and specialty relay, transorb and communications modules. Pre-printed I/O-specific adhesive label strips for quick marking of **ZIPLink** modules are provided with **ZIPLink** cables. See the following solutions to help determine the best **ZIPLink** system for your application.

Using the PLC I/O Modules to **ZIPLink** Connector Modules selector tables located in this section,

1. Locate your I/O module/PLC.
2. Select a **ZIPLink** module.
3. Select a corresponding **ZIPLink** cable.

Solution 2: DirectLOGIC I/O Modules to 3rd Party Devices

For connecting I/O to another device within close proximity of the I/O modules, no extra terminal blocks are necessary when using the **ZIPLink** Pigtail Cables. **ZIPLink** Pigtail Cables are prewired to an I/O terminal block with color-coded pigtail with soldered-tip wires on the other end.



Using the I/O Modules to 3rd Party Devices selector tables located in this section,

1. Locate your PLC I/O module.
2. Select a **ZIPLink** pigtail cable that is compatible with your 3rd party device.

Solution 3: GS Series and DuraPulse Drives Communication Cables

Need to communicate via Modbus RTU to a drive or a network of drives?

ZIPLink cables are available in a wide range of configurations for connecting to PLCs and SureServo, SureStep, Stellar soft starters and AC drives. Add a **ZIPLink** communications module to quickly and easily set up a multi-device network.

Using the Drives Communication selector tables located in this section,

1. Locate your drive and type of communications.
2. Select a **ZIPLink** cable and other associated hardware.



Solution 4: Serial Communications Cables

ZIPLink offers communications cables for use with DirectLOGIC, CLICK, and Productivity3000 CPUs, that can also be used with other communications devices. Connections include a 6-pin RJ12 or 9-pin, 15-pin and 25-pin D-sub connectors which can be used in conjunction with the RJ12 or D-Sub Feedthrough modules.

Using the Serial Communications Cables selector table located in this section,

1. Locate your connector type.
2. Select a cable.



Solution 5: Specialty ZIPLink Modules

For additional application solutions, **ZIPLink** modules are available in a variety of configurations including stand-alone relays, 24VDC and 120VAC transorb modules, D-sub and RJ12 feedthrough modules, communication port adapter and distribution modules, and SureServo 50-pin I/O interface connection.

Using the **ZIPLink** Specialty Modules selector table located in this section,

1. Locate the type of application.
2. Select a **ZIPLink** module.



Solution 6: ZIPLink Connector Modules to 3rd Party Devices

If you need a way to connect your device to terminal blocks without all that wiring time, then our pigtail cables with color-coded soldered-tip wires are a good solution. Used in conjunction with any compatible **ZIPLink** connector modules, a pigtail cable keeps wiring clean and easy and reduces troubleshooting time.

Using the Universal Connector Modules and Pigtail Cables table located in this section,

1. Select module type.
2. Select the number of pins.
3. Select cable.



DL05/06 PLC Input Module ZIPLink Selector				
PLC		ZIPLink		
Input Module	# of Terms	Component	Module Part No.	Cable Part No.
DO-10ND3	13	Feedthrough	ZL-RTB20	ZL-D0-CBL13
DO-10ND3F	13	Feedthrough		ZL-D0-CBL13
DO-16ND3	24	Feedthrough	ZL-LTB16-24-1	ZL-D0-CBL24-L
		Sensor		ZL-D0-CBL24-1L
FO-08NA-1	10	See Note 2		

DL05/06 PLC Combo In/Out Module ZIPLink Selector				
PLC		ZIPLink		
Combo Module	# of Terms	Component	Module Part No.	Cable Part No.
DO-07CDR	10	See Note 2		
DO-08CDD1	13	Feedthrough	ZL-RTB20	ZL-D0-CBL13

DL05/06 PLC Analog Module ZIPLink Selector				
PLC		ZIPLink		
Analog Module	# of Terms	Component	Module	Cable
FO-04AD-1	8	See Note 2		
FO-04AD-2	8			
FO-08ADH-1	13	Feedthrough	ZL-RTB20	ZL-D0-CBL13
FO-08ADH-2	13			
FO-04DAH-1	13			
FO-08DAH-1	13			
FO-04DAH-2	13			
FO-08DAH-2	13			
FO-2AD2DA-2	8	See Note 2		
FO-4AD2DA-1	8			
FO-4AD2DA-2	8			
FO-04RTD	Matched Only			
FO-04THM	Matched Only			

DL05/06 PLC Output Module ZIPLink Selector				
PLC		ZIPLink		
Output Module	# of Terms	Component	Module Part No.	Cable Part No.
DO-10TD1	13	Feedthrough	ZL-RTB20	ZL-D0-CBL13
DO-16TD1	24	Feedthrough	ZL-RTB20	ZL-D0-CBL24 *
		Fuse	ZL-RFU20 ³	ZL-D0-CBL24 *
		Relay (sinking)	ZL-RRL16-24-1	ZL-D0-CBL24 *
DO-10TD2	13	Feedthrough	ZL-RTB20	ZL-D0-CBL13
DO-16TD2	24	Feedthrough	ZL-RTB20	ZL-D0-CBL24 *
		Fuse	ZL-RFU20 ³	ZL-D0-CBL24 *
		Relay (sourcing)	ZL-RRL16-24-2	ZL-D0-CBL24 *
DO-08TR	10	See Note 2		
FO-04TRS¹	13	Feedthrough	ZL-RTB20	ZL-D0-CBL13

DL05/06 PLC Fixed I/O ZIPLink Selector				
PLC		ZIPLink		
PLC	# of Terms	Component	Module Part No.	Cable Part No.
DL05	18	See Note 2		
DL06	20 (Input side only)	Feedthrough	ZL-RTB20	ZL-D06X-CBL20
	20 (Output side only)	Feedthrough	ZL-RTB20	ZL-D06Y-CBL20

- * Select the cable length by replacing the * with: Blank = 0.5 m, -1 = 1.0 m, or -2 = 2.0 m.
 - ¹ Caution: The FO-04TRS relay outputs are derated not to exceed 2A per point when used with the ZIPLink wiring system.
 - ² These modules are not supported by the ZIPLink wiring system.
 - ³ Note: Fuses (5 x 20 mm) are not included. See Edison Electronic Fuse section for (5 x 20 mm) fuse. S500 and GMA electronic circuit protection for fast-acting maximum protection. S506 and GMC electronic circuit protection for time-delay performance. Ideal for inductive circuits.
- To ensure proper operation, do not exceed the voltage and current rating of ZIPLink module. ZL-RFU20 = 2A per circuit; ZL-RFU40 = 400mA per circuit.



Power Budgeting for the DL06

The DL06 has four option module slots. To determine whether the combination of modules you select will have sufficient power, you will need to perform a power budget calculation.

Power supplied

Power is supplied from two sources: the internal base unit power supply and, if required, an external supply (customer furnished). The D0-06xx (AC powered) PLCs supply a limited amount of 24VDC power. The 24VDC output can be used to power external devices.

For power budgeting, start by considering the power supplied by the base unit. All DL06 PLCs supply the same amount of 5VDC power. Only the AC units offer 24VDC auxiliary power.

Be aware of the trade-off between 5VDC power and 24VDC power. The amount of 5 VDC power available depends on the amount of 24VDC power being used, and the amount of 24VDC power available depends on the amount of 5VDC power consumed. Determine the amount of internally supplied power from the table to the right.

Power required by base unit

Because of the different I/O configurations available in the DL06 family, the power consumed by the base unit itself varies from model to model. Subtract the amount of power required by the base unit from the amount of power supplied by the base unit. Be sure to subtract 5VDC and 24VDC amounts.

Power required by option modules

Next, subtract the amount of power required by the option modules you are planning to use. Again, remember to subtract both 5VDC and 24VDC.

If your power budget analysis shows surplus power available, you should have a workable configuration.

DL06 Power Supplied by Base Units		
Part Number	5 VDC (mA)	24 VDC (mA)
D0-06xx	1500mA	300mA
	2000mA	200mA
D0-06xx-D	1500mA	none

DL06 Base Unit Power Required		
Part Number	5 VDC (mA)	24 VDC (mA)
D0-06AA	800mA	none
D0-06AR	900mA	none
D0-06DA	800mA	none
D0-06DD1	600mA	280mA*
D0-06DD2	600mA	none
D0-06DR	950mA	none
D0-06DD1-D	600mA	none
D0-06DD2-D	600mA	none
D0-06DR-D	950mA	none

* Only if auxiliary 24VDC power is connected to V+ terminal.

DL06 Power Consumed by Other Devices		
Part Number	5 VDC (mA)	24 VDC (mA)
D0-06LCD	50mA	none
D2-HPP	200mA	none
DV-1000	150mA	none
C-more Micro-Graphic	210mA	none

Power Budgeting Example			
Power Source		5VDC power (mA)	24VDC power (mA)
D0-06DD1 (select row A or B)	A	1500mA	300mA
	B	2000mA	200mA
Current Required		5VDC power (mA)	24VDC power (mA)
D0-06DD1		600mA	280mA*
D0-16ND3		35mA	0
D0-10TD1		150mA	0
D0-08TR		280mA	0
F0-4AD2DA-1		100mA	0
D0-06LCD		50mA	0
Total Used		1215mA	280mA
Remaining	A	285mA	20mA
	B	785mA	note 1

* Auxiliary 24 VDC used to power V+ terminal of D0-06DD1 sinking outputs.

Note 1: If the PLC's auxiliary 24 VDC power source is used to power the sinking outputs, use power choice A, above.

DL05/06 Power Consumed by Option Modules		
Part Number	5 VDC (mA)	24 VDC (mA)
D0-07CDR	130mA	none
D0-08CDD1	100mA	none
D0-08TR	280mA	none
D0-10ND3	35mA	none
D0-10ND3F	35mA	none
D0-10TD1	150mA	none
D0-10TD2	150mA	none
D0-16ND3	35mA	none
D0-16TD1	200mA	none
D0-16TD2	200mA	none
F0-04TRS	250mA	none
F0-08NA-1	5mA	none
F0-04AD-1	50mA	none
F0-04AD-2	75mA	none
F0-08ADH-1	25mA	25mA
F0-08ADH-2	25mA	25mA
F0-04DAH-1	25mA	150mA
F0-08DAH-1	25mA	220mA
F0-04DAH-2	25mA	30mA
F0-08DAH-2	25mA	30mA
F0-2AD2DA-2	50mA	30mA
F0-4AD2DA-1	100mA	40mA
F0-4AD2DA-2	100mA	none
F0-04RTD	70mA	none
F0-04THM	30mA	none
D0-DEVNETS	45mA	none
H0-CTRIO2	250mA	none
H0-ECOM100	300mA	none
F0-08SIM	1mA	none
D0-DCM	250 mA	none
F0-CP128	150 mA	none
F0-08SIM	1 mA	none