

Alco Controls

Thermo™-Expansion Valves T-, L-, 935-, ZZ-Series

Technical Bulletin

Alco Control Take-apart Thermo™-Expansion Valves are designed for air conditioning, chillers, rooftops, close control, A/C transportation, heat pumps, industrial cooling process, refrigeration and numerous special applications. The new Take-A-Part expansion valves are ideal for those applications requiring flexibility in selection of capacity and excellent stable superheat control under varying operating conditions such as high and low head pressure, wide load variation and partial load down to 10%. Valves with XB power elements can be applied in systems with Copeland Digital Scroll™ Compressors.

Features

- Take-apart design consists of power element, cage and flange
- 46 bar maximum working pressure with XB power element
- 17 cage assemblies provide a wide capacity range (1.3 to 209 kW, R404A)
- XB long life laser welded stainless steel power element resists corrosion
- Large diaphragm eliminates disturbances to the valve and provides smoother and consistent valve control over wide range of operation
- Constant superheat across a wide application range
- Tailored charges for different applications
- T-Series: universal expansion valve for evaporating temperature down to -45°C
- ZZ-Series: expansion valves for evaporating temperature down to -100°C
- L / 935-Series: desuperheating of two stage compressors or hot gas bypass applications
- Flanges: brazing ODF/ODM connection with straight through and angle style configuration



TCLE/LCLE



XB1019

Selection Table: T-Series

Series	R134a		R404A/R507		R407C		R410A		Orifice Type	Power Element
	Type	kW	Type	kW	Type	kW	Type	kW		
TCLE-	25MW	1.5	25SW	1.3	50NW	2.1	50ZW	2,2	X22440-B1B	XB1019...1B
	75MW	2.9	75SW	2.6	100NW	4.0	100ZW	4,3	X22440-B2B	
	150MW	6.1	150SW	5.6	200NW	8.5	250ZW	9,2	X22440-B3B	
	200MW	9.3	200SW	8.4	300NW	12.9	400ZW	13,9	X22440-B3.5B	
	250MW	13.5	250SW	12.2	400NW	18.7	600ZW	20,2	X22440-B4B	
	350MW	17.3	400SW	15.7	550NW	24.0	750ZW	25,9	X22440-B5B	
	550MW	23.6	600SW	21.5	750NW	32.9	1000ZW	35,5	X22440-B6B	
	750MW	32.0	850SW	29.0	1000NW	44.4	1400ZW	48,0	X22440-B7B	
TJRE-	11MW	45	12SW	40	14NW	62	19ZW	67,7	X11873-B4B	XB1019...1B
	13MW	57	14SW	51	17NW	80	25ZW	86,4	X11873-B5B	
TERE	16MW	71	18SW	63	21NW	99	-	-	X9117-B6B	XC726...2B
	19MW	81	20SW	72	25NW	112	-	-	X9117-B7B	
	25MW	112	27SW	99	33NW	155	-	-	X9117-B8B	
	31MW	135	34SW	120	42NW	188	-	-	X9117-B9B	
TIRE-	45MW	174	47SW	154	52NW	241	-	-	X9166-B10B	XC726...2B
THRE-	55MW	197	61SW	174	71NW	273	-	-	X9144-B11B	
	68MW	236	77SW	209	94NW	327	-	-	X9144-B13B	

Note 1: See page 5 for flanges selection and connections sizes.

Note 2: Capacities are based on +4°C evaporating temperatures, +38°C liquid temperature (+43°C dew point of R407C).

Emerson SELECT program is available for selection of valves at other operating conditions.

Thermo™-Expansion Valves T-, L-, 935-, ZZ-Series

MOP Charges T-Series

Code	bar	Evaporating temperature range, °C				
		R134a	R404A	R407C	R507	R410A
15	1,0	-45...-16				
35	2,4	-45...0				
40	2,8		-45...-18		-45...-18	
55	3,8	-45...+11	-45...-10		-45...-10	
65	4,5					
75	5,2		-45...-2		-45...-2	
80	5,5		-45...0		-45...0	
100	6,9			-45...+14		
175	12,1					-45...+16

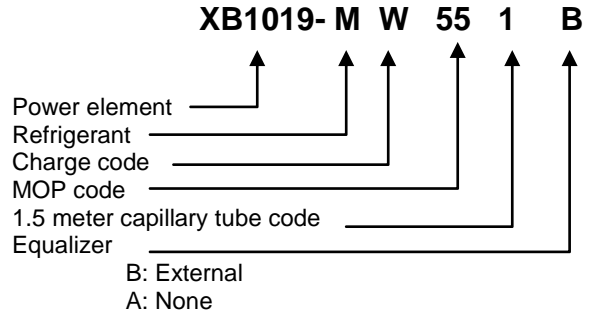

Type designation T-Series

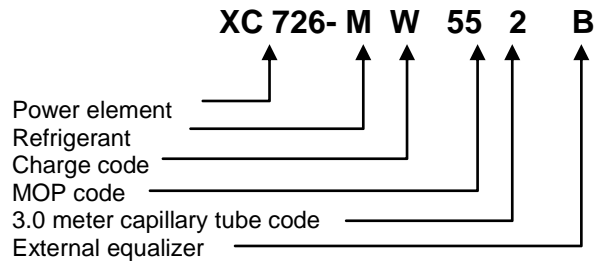
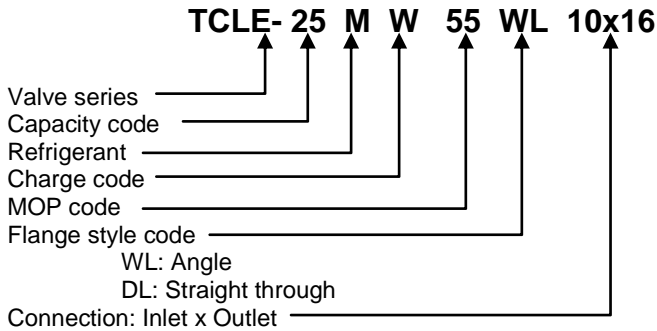

Selection Table: ZZ-Series

Series	R23		R404A / R507		Orifice	Connection Standard-Flange, Angle Solder/ODF		Power Element
	Type	Nominal Capacity kW	Type	Nominal Capacity kW		mm	inch	
	ZZCE	2 BG	1.9	2/4 SW		1.2	X 10-B01	
6 BG		4.0	1 1/2 SW	2.6	X 10-B02			
8 BG		6.8	2 1/2 SW	4.4	X 10-B03			
12 BG		10.8	3 1/2 SW	7.0	X 10-B04	C501 - 7mm 12 X 16	C501 - 7 1/2" X 5/8"	
17 BG		16.3	5 SW	10.6	X 10-B05			
25 BG		21.7	8 SW	14.1	X 10-B06			
31 BG	27.1	9 SW	17.6	X 10-B07	A 576mm 16 X 22 (22 X 28 ODM)	A 576 5/8" X 7/8" (7/8" X 1 1/8" ODM)		

Attention: To withstand stress at extremely low temperatures, ZZ-Series valves feature bronze bolts

Note 1: See page 5 for flanges selection and connections sizes.

Note 2: Capacities are based on +4°C evaporating temperatures, +38°C liquid temperature.

Emerson SELECT program is available for selection of valves at other operating conditions.

MOP Charges ZZ-Series

MOP Code	MOP		Evaporating Temperature Range (°C)	
	bar	Tmax	R 23	R 404A / R 507
	20	1,4	-66°C	-100 .. -71
35	2,4	-11°C		
40	2,8	-14°C		-75 .. -18
55	3,8	-7°C		-75 .. -10
60	4,1	-48°C	-100 .. -51	
125	8,6	-32°C	-100 .. -33	

Thermo™-Expansion Valves T-, L-, 935-, ZZ-Series

Type designation ZZ-Series

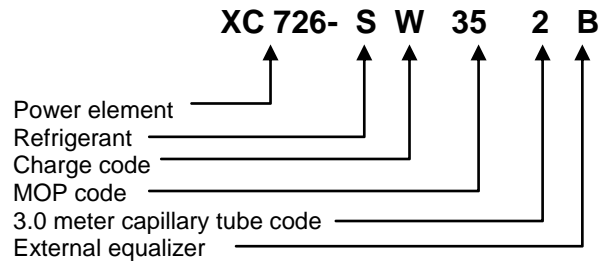
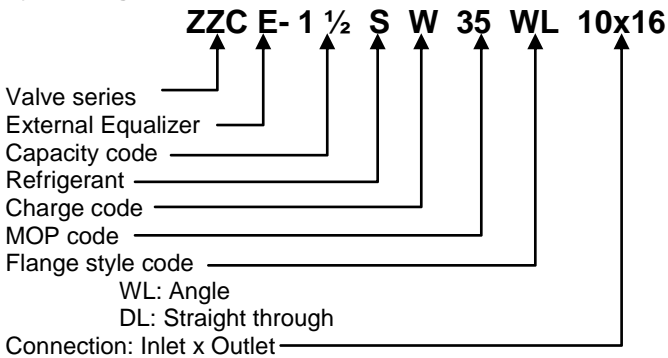

Selection Table: L-series

Valve Series	Size code*	R134a kW	R404A/R507 kW	R407C kW	R410A	Cage Type	Angle flange Type / connection		Power Element
							Metric	Imperial	
LCLE-	1*	1.5	1.3	2.1	2,2	X22440-B1B	C501-5mm	C501-5	XB1019...1B
	2*	2.9	2.6	4.0	4,3	X22440-B2B			
	3*	6.1	5.6	8.5	9,2	X22440-B3B			
	3.5*	9.3	8.4	12.9	13,9	X22440-B3.5B			
	4*	13.5	12.2	18.7	20,2	X22440-B4B	C501-7mm	C501-7	
	6*	17.3	15.7	24.0	25,9	X22440-B5B			
	7*	23.6	21.5	32.9	35,5	X22440-B6B	A576-mm	A576	
	9*	32.0	29.0	44.4	48,0	X22440-B7B			
LJRE-	11*	45	40	62	67,7	X11873-B4B	10331	10331	
	12*	57	51	80	86,4	X11873-B5B			
LERE	13*	71	63	99	-	X9117-B6B	9153mm	9153	XC726...2B
	14*	81	72	112	-	X9117-B7B			
	15*	112	99	155	-	X9117-B8B			
	16*	135	120	188	-	X9117-B9B			
LIRE-	17*	174	154	241	-	X9166-B10B			

Note 1: See page 5 for flanges selection and connections sizes.

Note 2: Capacities are based on +4°C evaporating temperatures, +38°C liquid temperature (+43°C dew point of R407C). Emerson SELECT program is available for selection of valves at other operating conditions.

Suction gas superheat selection

Charge code *	Refrigerant						
	R134a	R22	R404A/R507	R407A	R407F	R407C	R410A
CL	-	15	22K	16K	17K	13K	30K
GL	3	18	25	19	20	16	33
UL	20	34	40	33	34	31	47

Type designation L-Series

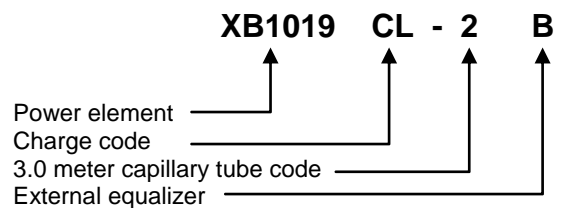
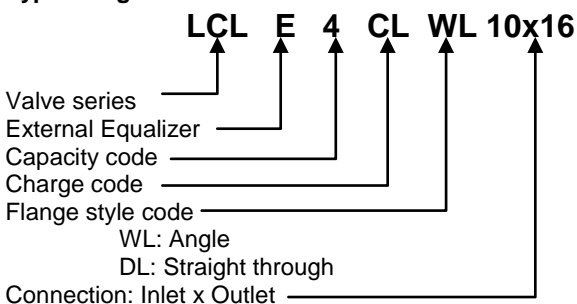

Selection table: 935-series

Valve Series	Size and code	R134a	R404A/R507	R407F	R407C	Cage Type	Angle flange Type / connection		Power Element
		kW	kW	kW	kW		Metric	Imperial	
935*-	A	4.0	3.8	5.8	5.6	X10-**01	C501-5mm	C501-5	XB1019-***-2A
	B	7.8	7.4	11.3	10.9	X10-**02			
	C	11.1	10.3	15.9	15.4	X10-**03			
	D	16.3	15.6	23.6	22.8	X10-**04	C501-7mm	C501-7	
	E	22.5	21.0	32.3	31.2	X10-**05			
	G	32.0	29.9	46.1	44.5	X10-**06	A576-mm	A576	
	X	46.6	43.5	67.1	64.9	X10-**07			

*) Temperature code	Temperature range °C	**) Spring code
3	-1 ... +17	B
6	+14 ... +38	C
7	+36 ... +50	A
105	+44 ... +70	C
106	+66 ... +94	C
100	+94 ... +121	C

***) Charge code
UL
KL
YL
YL
JL
LL

Note 1: See page 5 for flanges selection and connections sizes.

Note 2: Capacities are based on +4°C evaporating temperatures, +38°C liquid temperature (+43°C dew point of R407C). Emerson SELECT program is available for selection of valves at other operating conditions.

Type designation 935-Series

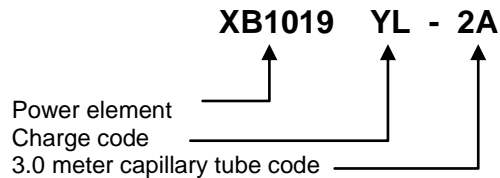
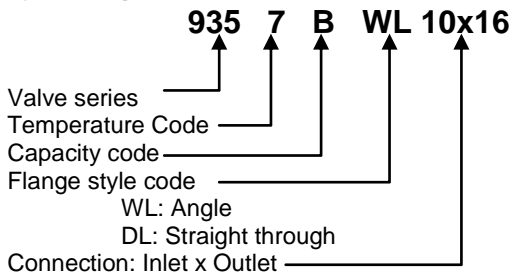

Technical data

CE marking	not required
Compatibility (not released for use with inflammable refrigerants)	HCFCs, HFCs, CO ₂ Mineral, Alkyl benzene and POE lubricants
TS: Medium temperature range temperature	T/L935-series-45 to +75°C ZZ-series: -100 to +75°C
Max. working pressure, PS	46 bar with XB power element
Factory test pressure	50.6 bar with XB power element
Max. working pressure, PS	31 bar with XC power element
Factory test pressure	34.1 bar with XC power element
Burst pressure	255 bar with XB power element
Burst pressure	160 bar with XC power element
Charges free from CFC and HCFC	Liquid without MOP Gas with MOP

Flange connections	Brass ODF or ODM
Vibration for non-connected and fastened valve	4g (0 to 1000 Hz, 1 octave /min.)
Shock	20g at 11 ms 80g at 1 ms
Accessories	Gasket set Bronze screws for ZZ
Directive	RoHS compliant
Package and delivery	Single

Thermo™-Expansion Valves T-, L-, 935-, ZZ-Series

Flanges: T- / L-Series

Valve series	Orifice type	Angle style		Straight through		Connection (inlet x outlet)	
		Type	Part No.	Type	Part No.	Metric	Imperial
TCLE / LCLE	X22440-B1B / B2B/ B3B / B3.5B / B4B	C501-5	803232	9761-3	803240	-	3/8"x5/8" ODF
		C501-5mm	803233	9761-3mm	803241	10x16mm ODF	
	X22440-B5B / B6B	C501-7	803234	9761-4	803350		1/2"x5/8" ODF
		C501-7mm	803235	9761-4mm	803243	12x16mm ODF	-
	X22440-B7B / B8B	-	-	6346-17	803330	16x22mm ODF	5/8"x7/8" ODF
		A576	803238	-	-	-	5/8"x7/8" ODF 7/8"x1-1/8" ODM
A576-mm		803239	-	-	16x22mm ODF 22x28mm ODM	-	
TJRE / LJRE	X11873-B4B / B5B	10331	803338	10332	803324	22x22mm ODF	7/8"x7/8" ODF 1-1/8"x1-1/8" ODM
TERE/ TIRE LERE/ LIRE	X9117-B6B / B7B / B8B / B9B / B10B	9153	803244	9152	803286	-	7/8"x7/8" ODF 1-1/8"x1-1/8" ODM
		9153-mm	803245	9152-mm	803287	22x22mm ODF 22x28mm ODM	
THRE	X9144-B11B / B13B	9149	803284	9148	803283	22x22mm ODF	7/8"x7/8" ODF 1-1/8"x1-1/8" ODM

Flanges: 935- / ZZ-Series

Valve series	Orifice type	Angle style		Straight through		Connection (inlet x outlet)	
		Type	Part No.	Type	Part No.	Metric	Imperial
935 / ZZ	X10-*01 / *02 / *03	C501-5	803232	9761-3	803240	-	3/8"x5/8" ODF
		C501-5mm	803233	9761-3mm	803241	10x16mm ODF	
	X10-*04 / *05	C501-7	803234	9761-4	803350		1/2"x5/8" ODF
		C501-7mm	803235	9761-4mm	803243	12x16mm ODF	-
	X10-*06 / *07			6346-17	803330	16x22mm ODF	5/8"x7/8" ODF
		A576	803238	-	-	-	5/8"x7/8" ODF 7/8"x1-1/8" ODM
		A576-mm	803239	-	-	16x22mm ODF 22x28mm ODM	-

Dimensions TCLE/LCLE / XB1019 (mm)

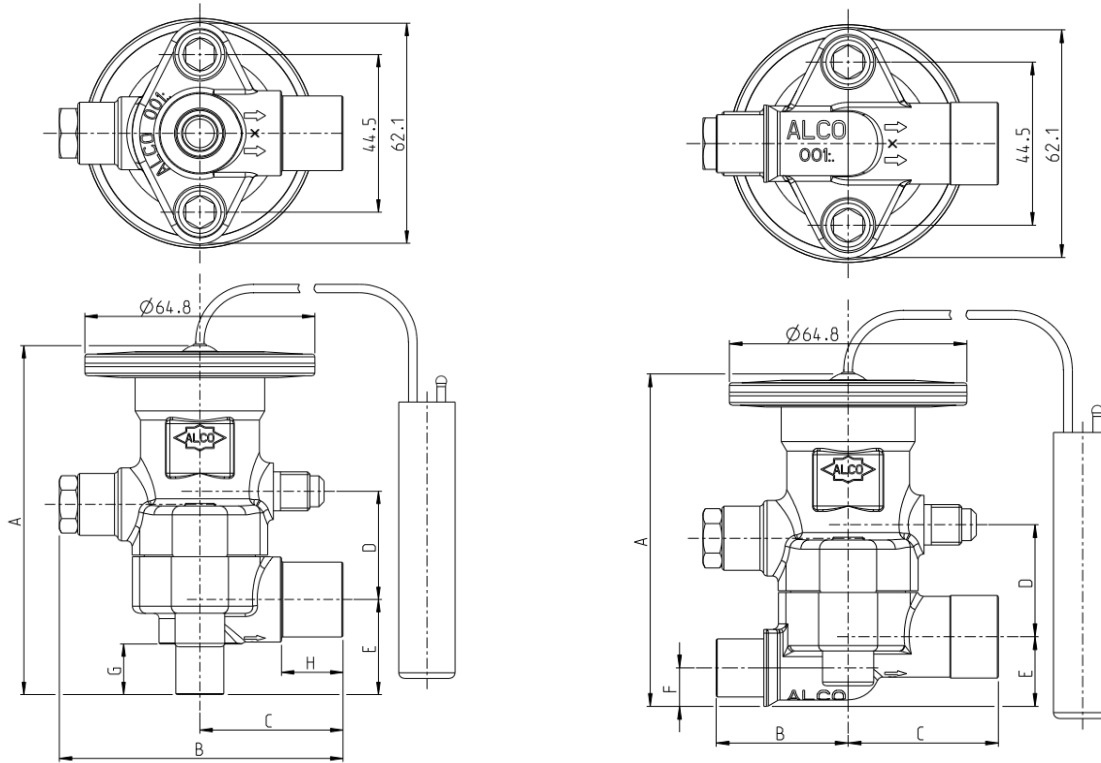

Angle Style Flanges TCLE/LCLE

Connections		Lay-in length		A	B	C	D	E	F	G	H	Weight kg
		Inlet	Outlet									
3/8	1/2 SAE			106	78	39	30	29				1,1
3/8	5/8 SAE			106				29				
1/2	5/8 SAE			113				35				
10	12 ODF	14	17	105	77	37		27				
10	16 ODF	14	21	105	80	40		-				
12	16 ODF	18	21	108	80	40		-				
16	22 ODF	21	25	124	90	51	43	27	29			
3/8	1/2 ODF	14	17	105	77	37	27				1,1	
3/8	5/8 ODF	14	21	105	80	40	27					
1/2	5/8 ODF	18	21	108	80	40	30					
5/8	7/8 ODF	21	25	124	90	51	34					43

Straight through Flanges TCLE/LCLE

3/8	1/2 SAE			95	45	50	31	17	10			1,2
3/8	5/8 SAE				45	55						
1/2	5/8 SAE				50	55						
10	12 ODF	8	10	95	36	40	31	9				1,1
10	16 ODF	8	13			41						
12	16 ODF	10	13			41						
3/8	1/2 ODF	8	10	97		40	33	10				1,15
3/8	1/2 ODF	8	13			41						
1/2	1/2 ODF	10	10			40						
1/2	5/8 ODF		13	95	41	41						
1/2	7/8 ODF		19			49						
5/8	5/8 ODF		13	98	49	41						
5/8	7/8 ODF	13	19			49						
5/8	1-18 ODF		13			60						
5/8	1-18 ODF	19	13			60						

Dimensions TJRE/LJRE XB1019 (mm)

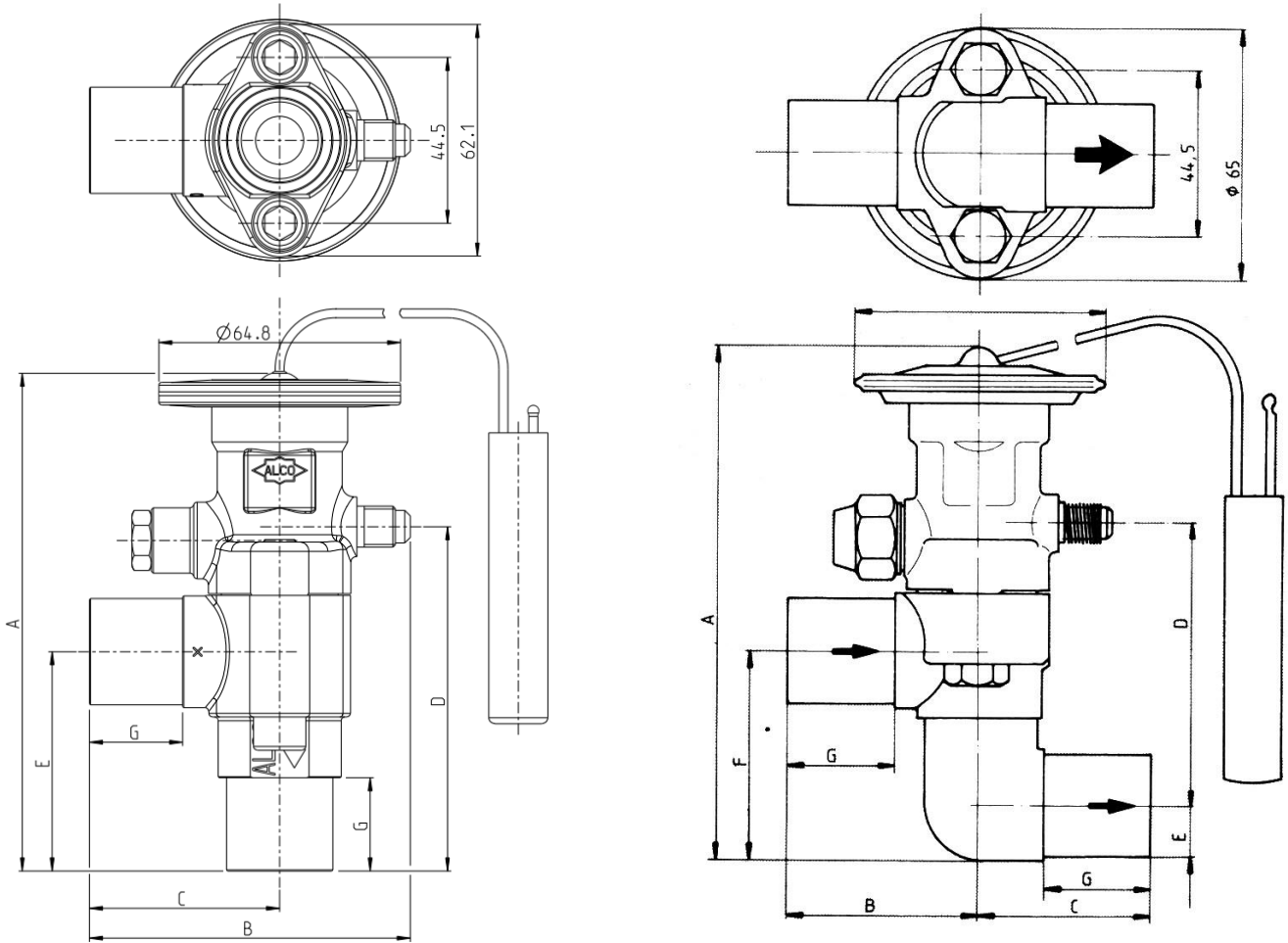

Angle Style Flanges TJRE/LJRE

Connections		Lay-in length		A	B	C	D	E	F	G	Weight kg
		Inlet	Outlet								
22	22 ODF	19	19	140	85	51	93	59		29	1,3

Straight through Flanges TJRE/LJRE

7/8	7/8 ODF	19	19	137	51	45	75	15	56	29	1,4
-----	---------	----	----	-----	----	----	----	----	----	----	-----

Dimensions TERE/LERE, TIRE/LIRE, THRE XC726 (mm)

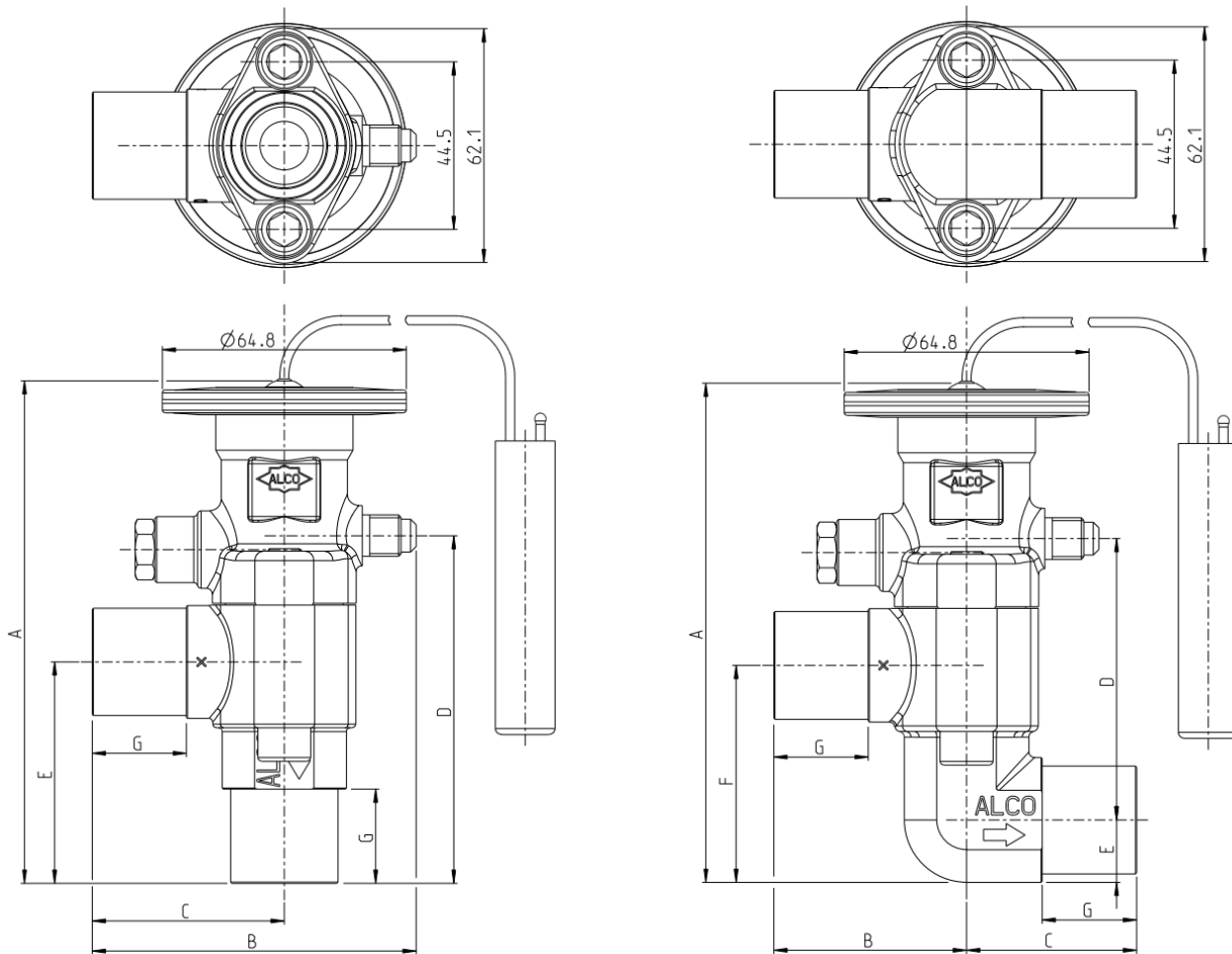

Angle Style Flanges Type 9153, 9153-MM for TERE, TIRE

Connections		Lay-in length		A	B	C	D	E	F	G	Weight kg
		Inlet	Outlet								
22	22 ODF	19	19	140	87	51	92	59		23	1,4
7/8	7/8 ODF	19	19	140			92	59		25	1,4

Angle Style Flanges Type 9149 for THRE

22,2	22,2 ODF	19	19	154	87	51	106	73		25	1,45
7/8	7/8 ODF	19	19	154			106	73		25	1,45

Straight Through Flanges Type 9152 for TERE, TIRE

22,2	22,2 ODF	19	19	139	51	45	74	16,5	58	25	1,5
7/8	7/8 ODF	19	19	139							1,5

Straight through Flanges Type 9148 for THRE

22,2	22,2 ODF	19	19	139	51	45	74	16,5	58	25	1,45
7/8	7/8 ODF	19	19	139							1,45