

Adwa

USER MANUAL

AD 131 and AD 132 pH/mV/Temperature Waterproof Meters



Dear Customer,

Thank you for choosing an Adwa product.

Please read carefully this manual before starting operations.

This instrument is in compliance with the EMC directive 2004/108/EC and its standards, and Low Voltage Directive 2006/95/EC and its standards for electrical equipments.

For additional technical information, please e-mail us at sales@adwainstruments.com.

WARRANTY

Adwa warrants this product to be free of defects in material and workmanship as stated in the operating manual. If repair or adjustment is necessary and has not been the result of abuse, misuse or improper handling within the warranty period, please contact your dealer or the nearest Adwa Office for the RGA (Return Goods Authorization) number to put on the outside of your package. Warranted service will be made without charge. **The meter is warranted for a period of 2 years, while probes are warranted for 6 months.** The warranty period commences from the original date of sale. Warranty is only valid when the product is used under normal conditions and in accordance with the instruction manual. The warranty is void if the instrument is repaired or serviced by unauthorized personnel, not used in accordance to the instructions, or if non-Adwa accessories such as buffer solutions, probes, etc. are used in conjunction with the meter. Adwa will not be held responsible for any accident whether directly or indirectly, caused by the use of this instrument.

TABLE OF CONTENTS

Introduction	4
Technical Data	6
Front and Top Panels	8
Operational Guide	10
pH Calibration	16
Relative mV Calibration	25
Good Laboratory Practice (GLP)	26
Setup	31
Log-on-demand	34
Hold Function	39
Printing (AD132 only)	40
Battery Replacement	44
Temperature Calibration (for technical personnel only)	45
mV Calibration (for technical personnel only)	47
PC Interface (AD132 only)	49
pH Electrode Conditioning & Maintenance	50
Troubleshooting Guide	52
Electrodes, Probes and Solutions	54

INTRODUCTION

AD131 and **AD132** are heavy-duty portable waterproof meters for pH, ORP (Oxidation Reduction Potential) and temperature measurements, designed to provide laboratory results and accuracy even under harsh industrial conditions.

Main features include:

- 7 memorized buffers for pH calibration (pH 1.68, 4.01, 6.86, 7.01, 9.18, 10.01 and 12.45)
- Messages on the LCD to make the calibration easy and accurate
- pH readings with manual or automatic temperature compensation
- Calibration time-out alarm
- Log-on-demand
- HOLD feature to freeze stable reading on the LCD
- GLP feature to view last calibration data for pH and relative mV
- PC interface (**AD132** only)

- Connection to an external serial printer (**AD132** only) with the following specification:
 - at least 16 characters/line
 - baud rate 9600
 - 9-pin RS232 input

Both models are supplied complete with:

- **AD1230B** pH electrode with double ceramic junction, BNC connector and 1 m cable
- **AD7662** stainless steel temperature probe, 1 m cable
- 1.5V AA alkaline batteries (4 pcs)
- User manual

TECHNICAL DATA

Range	-2.00 to 16.00 pH ±2000 mV -20.0 to 120.0 °C (-4.0 to 248.0 °F)
Resolution	0.01 pH 0.1 mV (±999.9 mV) / 1 mV (outside) 0.1 °C (0.1 °F)
Accuracy (@25 °C/77 °F)	±0.01 pH ±0.2 mV up to ±699.9 mV ±0.5 mV up to ±999.9 mV ±2 mV (outside) ±0.4 °C (±0.7 °F) excluding probe error
Relative mV Offset	± 2000 mV
pH Calibration	Up to 5-point calibration, with 7 standard buffers (pH 1.68, 4.01, 6.86, 7.01, 9.18, 10.01, 12.45)
Temperature Compensation	Manual or automatic, -20.0 to 120.0 °C (-4.0 to 248.0 °F)
pH Electrode	AD1230B
Temperature Probe	AD7662
Log-on-demand	500 samples
Printer (AD132 only)	External serial printer

PC Interface (AD132 only)	RS232 port
Input Impedance	10^{12} Ohm
Environment	0 to 50 °C (32 to 122 °F) RH max. 100% non-condensing
Power Supply	4 x 1.5 V AA, alkaline battery
Battery Life	Approx. 300 hours of continuous use
Auto-off	User selectable: 5 minutes or disabled
Dimensions	188 x 96 x 70 mm
Weight	460 g

FRONT AND TOP PANELS

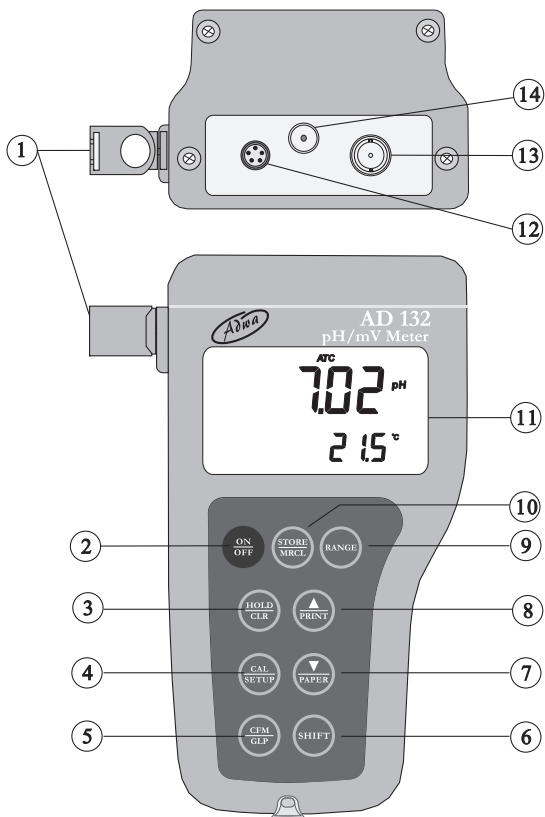

1. Holders for probes
2. **ON/OFF** key, to turn the instrument ON and OFF
3. **HOLD/CLR** key, to freeze stable reading on the LCD and clear calibration or logged data
4. **CAL/SETUP** key, to enter/exit calibration mode or enter/exit SETUP mode
5. **CFM/GLP** key, to confirm value and display GLP information
6. **SHIFT** key, to activate the key second function. Press first SHIFT and then the selected key. The SHIFT tag is displayed until the second key is pressed
7. **DOWN arrow/PAPER** (PAPER for **AD132** only) to manually decrease the value of temperature or other parameters, or to pull out printer paper
8. **UP arrow/PRINT** (PRINT for **AD132** only) key, to manually increase the value of temperature or other parameters, to obtain a printout or cancel printing
9. **RANGE** key, to select measurement range or switch focused data
10. **STORE/MRCL** key, to store measured data and enter/exit the logged data viewing mode
11. Liquid Crystal Display (LCD)
12. RS232 connector (**AD132** only)
13. BNC connector for pH or ORP electrodes
14. Temperature probe socket

OPERATIONAL GUIDE

- The meter is supplied complete with four 1.5V AA alkaline batteries. Remove the rear cover, unwrap the batteries and install them while paying attention to the correct polarity (see “Battery Replacement” section).
- Connect pH electrode and temperature probe to the BNC and temperature sockets on the top of the instrument. Slide the BNC protection sleeve to completely cover the BNC connector.

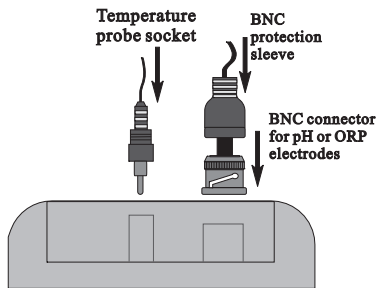

- The temperature probe is used in conjunction with the pH electrode to utilize the meter’s ATC capability, but it can also be used independently to take temperature measurements. If the probe is disconnected, the temperature can be set manually using the arrow keys.

INSTRUMENT START-UP

- Turn the instrument on by pressing ON/OFF.
- At start-up the display shows all the used segments for a few seconds (or while the button is held), followed by date and time, then enters the measurement mode.

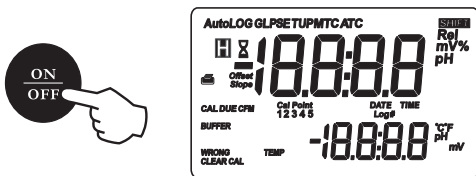

pH MEASUREMENTS

Make sure the instrument has been calibrated before taking pH measurements.

- If necessary, press RANGE to enter the pH mode.
- Remove the electrode tip protection bottle. Submerge the pH electrode tip (4 cm) and the temperature probe into the sample to be tested.
- Allow a few seconds for the electrode to stabilize.



- The pH reading is displayed on the primary LCD and the temperature on the secondary LCD.

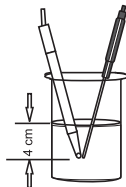
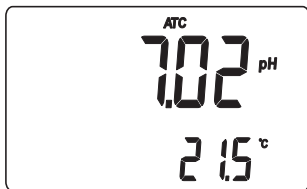

- If measurements are taken successively in different samples, it is recommended to rinse the electrode thoroughly with deionized or tap water. Then to condition the electrode, rinse it with some of the next sample to be measured before immersing it into the solution.
- Since the pH reading is affected by temperature, in order to measure the pH accurately, the meter is provided with temperature compensation feature. To use the automatic temperature compensation (ATC) feature, connect and immerse the **AD7662** temperature probe into the sample as close as possible to the electrode and wait for a few seconds.

- If the temperature of the sample is known, manual temperature compensation (MTC) can be performed. Disconnect the temperature probe and the display will show the default temperature of 25 °C (77 °F) or the last temperature reading with the °C (or °F) tag blinking.
- The temperature value can be adjusted using the arrow keys.

ORP (mV) MEASUREMENTS

Oxidation- reduction potential (REDOX) measurements provide the quantification of the oxidizing or reducing power of the tested sample.

To correct perform a redox measurement, the surface of the ORP electrode must be clean and smooth.

- Press RANGE to enter the mV mode.
- Immerse the tip of the ORP electrode at least 4 cm into the solution to be tested and wait a few seconds for the reading to stabilize.

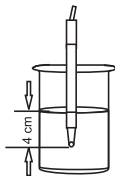

- The instrument displays the mV reading on the primary LCD and the temperature on the secondary LCD.



- If the reading is out of range, the closest full-scale value will be displayed blinking on the primary LCD.

RELATIVE mV MEASUREMENTS

To enter the relative mV mode, press the RANGE key. The relative mV reading will be displayed on the primary LCD and the current temperature value on the secondary LCD.

The relative mV reading is equal to the difference between the absolute mV input value and relative mV offset established in the relative mV calibration.



TEMPERATURE MEASUREMENTS

Connect the **AD7662** temperature probe to the appropriate socket. Immerse the temperature probe into the solution and allow the reading to stabilize.



Notes:

- The temperature can be displayed in Celsius ($^{\circ}\text{C}$) or Fahrenheit ($^{\circ}\text{F}$) degrees (see “Setup” section for details).
- Make sure that the temperature probe is immersed in the same sample that is measured.

pH CALIBRATION

The instrument should be recalibrated:

- Whenever the pH electrode is replaced
- At least once a week
- After testing aggressive chemicals
- If the “CAL DUE” message blinks during measurement

PREPARATION

Pour small quantities of the buffer solutions into clean beakers. If possible, use plastic beakers to minimize any EMC interferences.

For accurate calibration, use two beakers for each buffer solution: the first one for rinsing the electrode and the second for calibration.

If you are measuring in the acidic range, use pH 4.01 or 1.68 as second buffer. If you are measuring in the alkaline range, use 10.01/9.18 or 12.45 as second buffer.

For extended range measurements (acidic and alkaline), perform a five-point calibration by selecting five of the available buffers.

PROCEDURE

The meter allows to choose among 7 memorized buffer values: pH 1.68, 4.01, 6.86, 7.01, 9.18, 10.01 and 12.45.

For accurate measurements it is recommended to perform a five-point procedure. However, at least a two-point calibration is suggested.

The instrument will automatically skip the buffers already used and require a minimum difference of 0.2 pH unit between two buffers used for calibration.

A new calibration will override existing stored calibration data. The slopes adjacent to the calibration points will be reevaluated.

If the new calibration point has no correspondence in the existing stored calibration data, it is simply added or the instrument will ask which buffer will be replaced by the current one.

If at least a two-point calibration has been performed and an offset correction of the electrode is desired, keeping unchanged the existing slopes, perform a one-point calibration selecting the “OFFS” option in the setup menu. If the “Pnt” option is selected, the slopes adjacent to the calibration points will be reevaluated.

FIVE-POINT CALIBRATION

- Immerse the pH electrode and the temperature probe approximately 4 cm into the first buffer solution (pH 1.68, 4.01, 6.86, 7.01, 10.01 or 12.45) and stir gently. The temperature probe should be close to the pH electrode.

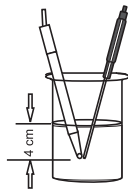

- To enter the pH calibration mode, press CAL from pH measurement mode.



- The instrument will display the measured pH on the primary LCD and the “7.01 pH” buffer on the secondary LCD, together with “CAL” and “Cal Point 1” tags.

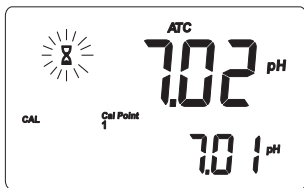

- If necessary, use the arrow keys to select a different buffer value.



- The hourglass symbol will blink on the LCD until the reading is stable.
- When the reading is stable and close to the selected buffer, the “CFM” tag blinks. Press the CFM key to confirm calibration. 
- The calibrated value is then displayed on the primary LCD and the secondary LCD shows the second expected buffer value, together with the “CAL” and “Cal Point 2” tags.

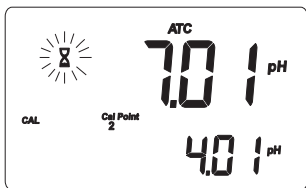

Note: If the buffer is not recognized, the “WRONG” message blinks to advise the user. Change buffer and proceed.

- After the first calibration point is confirmed, immerse the pH electrode and the temperature probe approximately 4 cm into the second buffer solution and stir gently. The temperature probe should be close to the pH electrode.

- If necessary, use the arrow keys to select a different buffer value.
- The hourglass symbol will blink on the LCD until the reading is stable.
- When the reading is stable and close to the selected buffer, the “CFM” tag blinks (or “WRONG” for buffer not recognized). Press the CFM key to confirm calibration.
- The calibrated value is then displayed on the primary LCD and the secondary LCD shows the third expected buffer value.
- After the second calibration point is confirmed, immerse the pH electrode and the temperature probe approximately 4 cm into the third buffer solution and stir gently. The temperature probe should be close to the pH electrode.
- If necessary, use the arrow keys to select a different buffer value.
- The hourglass symbol will blink on the LCD until the reading is stable.
- When the reading is stable and close to the selected buffer, the “CFM” tag blinks (or “WRONG” for buffer



not recognized). Press the CFM key to confirm calibration.



- The calibrated value is then displayed on the primary LCD and the secondary LCD shows the fourth expected buffer value.
- After the third calibration point is confirmed, immerse the pH electrode and the temperature probe approximately 4 cm into the third buffer solution and stir gently. The temperature probe should be close to the pH electrode.
- If necessary, use the arrow keys to select a different buffer value.
- The hourglass symbol will blink on the LCD until the reading is stable.
- When the reading is stable and close to the selected buffer, the “CFM” tag blinks (or “WRONG” for buffer not recognized). Press the CFM key to confirm calibration.
- The calibrated value is then displayed on the primary LCD and the secondary LCD shows the fifth expected buffer value.



- After the fourth calibration point is confirmed, immerse the pH electrode and the temperature probe approximately 4 cm into the third buffer solution and stir gently. The temperature probe should be close to the pH electrode.
- If necessary, use the arrow keys to select a different buffer value.
- The hourglass symbol will blink on the LCD until the reading is stable.
- When the reading is stable and close to the selected buffer, the “CFM” tag blinks (or “WRONG” for buffer not recognized). Press the CFM key to confirm calibration.
- The instrument stores the calibration values and returns to normal measurement mode.



FOUR, THREE or TWO-POINT CALIBRATION

Proceed as described in the “Five-point calibration” section and press CAL after the appropriate accepted calibration point. The instrument will memorize the calibration data and return to normal measurement mode.

ONE-POINT CALIBRATION

- Two setup options are available: “Pnt” and “OFFS”.
- If the “Pnt” option is selected, the adjacent slopes will be reevaluated.
- If the “OFFS” option is selected, an electrode offset correction is performed keeping unchanged the existing slopes.
- Proceed as described in the “Five-point calibration” section and press CAL after the first accepted calibration point. The instrument will memorize the single point calibration data and return to normal measurement mode.

Notes:

- Press RANGE to toggle between pH buffer and temperature reading during calibration.
- Each time a buffer is confirmed, the new calibration parameters replace the old data of the corresponding buffer.
- If current confirmed buffer has no correspondence in the stored calibration, it will be added to the existing calibration data. If the stored calibration is a five-point procedure, the instrument will ask which buffer should be replaced.

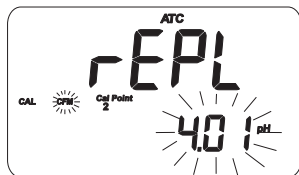

Use the arrow keys to select the buffer to be replaced, then press CFM to confirm or CAL to exit calibration without replacing.

CLEAR CALIBRATION

If the SHIFT and CLR keys are pressed at any time during calibration, the “CLEAR CAL” tag lights up and the “donE” message is displayed on the secondary LCD.

All previous calibrations are cleared and the instrument continues the procedure. The points already confirmed for the current calibration are not deleted.

The “CAL DUE” message will blink in measurement mode to advise the user that a pH calibration is required.

Note: If SHIFT and CLEAR are pressed during the first calibration point, the instrument returns to measurement mode.

RELATIVE mV CALIBRATION

- To enter relative mV calibration mode, press CAL from relative mV measurement mode. The relative mV is displayed on the primary LCD and the absolute mV value on the secondary LCD.
- Use the arrow keys to change the displayed relative mV value.
- When the reading is stable and the relative mV offset is inside the offset window (± 200.0 mV), the CFM tag will be displayed.
- Press CFM to confirm relative mV calibration and the instrument will return to normal measurement mode.
- If the absolute mV reading is out of range or the relative mV offset is out of the offset window, the WRONG tag will blink. Change the input value or the relative mV offset to complete the calibration procedure.

GOOD LABORATORY PRACTICE (GLP)

GLP is a set of functions that allows data storage (and retrieval) about the electrode status and maintenance.

All data regarding pH and relative mV calibrations are stored in the instrument memory.

To enter GLP mode, press SHIFT and then GLP key.

If no calibration has been performed, the “no CAL” message will blink.



CALIBRATION TIME-OUT ALARM

The instrument allows to set the number of days (from 1 to 7) before the next required pH calibration. The default setting is “OFF” (disabled).

At start-up the instrument checks if the calibration time-out has expired. If yes, the “CAL DUE” message blinks to advise the user that a new calibration is required.

Note: If the instrument was not calibrated or all calibration data were cleared, the “CAL DUE” message is displayed even if the feature is disabled in the setup menu.

LAST pH CALIBRATION DATA

The last pH calibration data are stored automatically after a successful calibration.

To view the pH calibration data, from pH measurement mode press SHIFT and then GLP key. The instrument will display the date (yyyy.mm.dd) of last calibration.



Use the up arrow key to view all calibration parameters in the following sequence:

- The time (hh:mm) of the last calibration.



- The pH calibration offset.

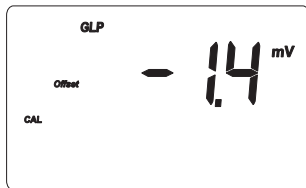

- pH calibration slope (the GLP slope is the average of the calibration slopes; the percentage is referred to the ideal value of 59.16 mV/pH).



- Calibration buffers in the order used for calibration, together with the corresponding warnings.



- Calibration time-out alarm status. The display shows “OFF” if the feature is disabled, or the days remaining before the calibration alarm will be activated, or after the calibration is expired (e.g. -3).



- The instrument ID.



Notes:

- The “OLd” message displayed beside a buffer value means that this buffer was not used during last calibration. Press SHIFT and then SETUP key to see the old calibration date (or time, if old calibration date is the same as the last procedure).
- The “no buF” message means that calibration was performed at less than five points.

LAST RELATIVE mV CALIBRATION DATA

Last relative mV calibration data are stored automatically after a successful calibration.

To view the relative mV calibration data, from normal relative mV measurement mode press SHIFT and then GLP key. The instrument will display the date (yyyy.mm.dd) of the last calibration.

Use the up arrow key to view all logged calibration parameters in the following sequence:

- Last calibration date and time
- Relative mV calibration offset
- Instrument ID as in pH GLP mode

Press SHIFT and then GLP key at any moment to return to normal measurement mode.

SETUP

Setup mode allows viewing and modifying the following parameters:

- Calibration alarm time-out
 - One-point calibration behavior
 - Temperature measure unit
 - Current date (yyyy.mm.dd)
 - Current time (hh:mm)
 - Printer status (**AD132** only)
 - Auto-off
 - Baud rate (serial communication, **AD132** only)
 - Command prefix (serial communication, **AD132** only)
 - Instrument ID
- To enter SETUP mode, from measurement mode press SHIFT and then SETUP.
 - Press CAL to change the item value. The selected item (e.g. hour, while setting the time) and “CFM” tag will blink.
 - Use the arrow keys to scroll the available values.

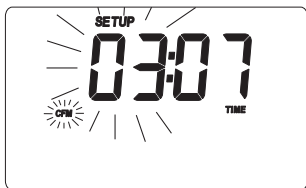

- If another item has to be set (e.g. minutes), press RANGE or left/right arrow key, and the item will start blinking.

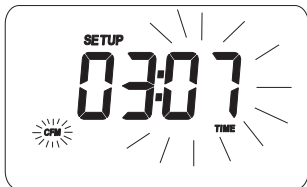

- Use the arrow keys to scroll the available values.
- Press CFM to confirm or CAL to escape.
- Use the arrow keys to select the next/previous parameter.

The following table lists all the available SETUP parameters, their valid values and the factory settings (default):

Item	Description	Valid values	Default
CAL DUE	Time-out alarm	OFF, 1 to 7 days	OFF
1 Pnt	1-point cal. behavior	Pnt, OFFS	Pnt
tEMP	Temperature unit	°C, °F	°C
Date	Date (yyyy.mm.dd)	2000.01.01 to 2099.12.31	2004.01.01
Time	Time (hh:mm)	00:00 to 23:59	00:00
 (AD132 only)	Printer status	ON, OFF	OFF
bAUd (AD132 only)	Baud rate	600, 1200, 2400	2400 4800, 9600
PrEF (AD132 only)	Command prefix	0 to 47	16
AOFF	Auto-off	no or 5 minutes	no
In Id	Instrument ID	0000 to 9999	0000

LOG-ON-DEMAND

This feature allows the user to log pH and Rel mV measurements, together with temperature.

Moreover, for **AD132** all logged data can be transferred to a PC or printed through the RS232 port.

Both models **AD131** and **AD132** can store up to 500 samples into memory.

LOGGING

To store the current reading into memory, press the STORE key from measurement mode.



The instrument displays the current date (mm.dd) on the primary LCD, while the secondary LCD shows the record number with the “LOG” tag blinking for a few seconds and then the number of free locations.

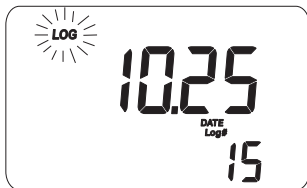

If there are less than 6 memory locations left, the record number and the “Lo” message will blink for a few seconds to alert the user, and then the number of free locations is displayed.

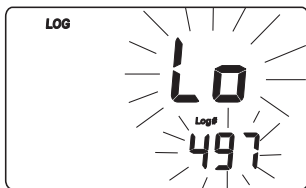

If the logging space is full, the “FULL LOC” message will be displayed for a few seconds together with the “LOG” tag blinking, followed by the “FrEE 0” message.



The instrument returns to normal measurement mode.

VIEWING LOGGED DATA

To retrieve the information stored, press SHIFT and then MRCL from measurement mode. If no data were logged, the “no rEC” message blinks on the LCD.

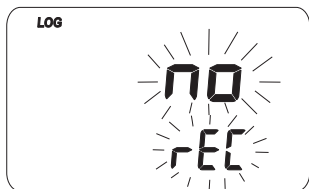

Otherwise, the instrument displays the memorized pH or relative mV reading, and the lot number.

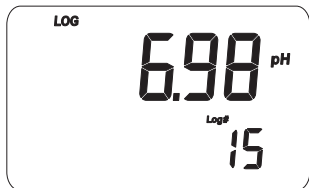

Pressing SHIFT and then SETUP key while in memory recall mode, the secondary LCD will toggle between the lot and the record number. Use the arrow keys to select a different lot or record.

Press RANGE key to scroll all logged parameters, displayed as shown in the table below:

Parameter	Primary LCD	Secondary LCD
mV	mV reading	Temperature
TIME	Hour & minutes	Seconds
DATE	Year	Month & day
OFFSET	Offset value	Lot or record number
SLOPE	Slope value	Lot number

Notes:

- To view the previous logged parameter, press the left arrow key.
- In relative mV memory recall mode, the offset value is not available and the display shows dashes “----”.
- The record number is an identification number inside a lot.

After scrolling all logged parameters, the meter displays the “dEL” message together with the lot number.

Note: Pressing SHIFT and then SETUP key, the instrument toggles between record number and “del ALL”.

- Press SHIFT and then CLEAR to delete the selected record or all records.

Note: Positions remain free in the log-on-demand lot by deleting the last logged sample or all lot.

- If the “dEL All” option was selected, all logged data are deleted and the instrument returns to normal measurement mode.



- Press SHIFT and MRCL at any time to return to measurement mode.

HOLD FUNCTION

To freeze a stable reading on the LCD, press HOLD key from normal measurement mode.

The “Auto” and “H” tags will blink on the LCD until the reading stabilizes.

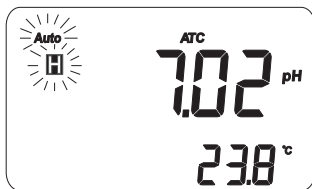

When the reading is stable, the “Auto” and “H” tags stop blinking and the reading is frozen.

Press HOLD key again to return the normal measurement mode.

Note: Pressing RANGE the instrument will skip to the displayed range, without leaving the HOLD mode. The STORE key also holds HOLD mode. Pressing SHIFT and then SETUP, GLP or MRCL key, the instrument leaves the HOLD mode and performs the selected function.

PRINTING (AD132 only)

When connected to an external serial printer, a complete set of information can be printed.

Printer specifications:

- at least 16 characters / line
- baud rate 9600
- 9-pin RS232 input

Data can be printed on demand (from measurement, GLP and SETUP modes) by pressing SHIFT and then PRINT.

Note: To cancel printing, press SHIFT and then PRINT again.

While in pH measurement mode, the printout provides the following information:

Date	2004/01/01
Time	02:25:17
pH	7.01
mV	-23.2
°C	26.3

When in GLP mode, the printout provide the following information:

- For pH range:

```

GLP pH
Instr ID      0003
Date         2004/01/01
Time        01:04:32
Cal Time Out OFF
Offset      -22.9mV
Slope       100.0%
Cal Buffers:
pH          7.01
  
```

- For relative mV range:

```

GLP Rel mV
Instr ID      0003
Date         2004/01/01
Time        02:27:35
Off.RelmV    -23.3
  
```

- Setup mode: if SHIFT and PRINT are the first keys pressed after entering the setup mode, a setup table of contents will be printed:

```

INSTRUMENT SETUP
Calibration
    Alarm Time Out
One point cal
    behavior
Temperature unit
Current Date
Current Time
Printer      ON/OFF
AutoOff     5/NO
Baud rate
Command prefix
Instrument ID
CAL-enter in
    modifying mode
SET-exit SETUP
RANGE-select
    parameter
See also items
Help printings
  
```

- When exiting the setup mode, the instrument asks if the setup report has to be printed. The “Prn” message will be displayed, together with the printer symbol () and the CFM tag blinking.

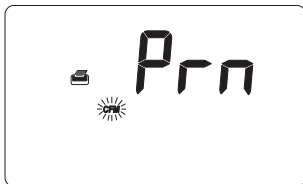

- Press CFM to print the setup report or CAL to exit without printing.

SETUP REPORT	
Instr ID	0003
Cal Time Out	OFF
One Cal Point	
	pnt
Date	2004/01/01
Time	02:28:34
Printer	ON
Auto-off	no
Baud Rate	2400
Comm prefix	16
Temperature	°C

From setup mode, if CAL and then PRINT is pressed for a chosen parameter, a help printout will provide the following information (e.g. Alarm Time-Out):

```
SET
ALARM TIME OUT
(OFF or 1-7)
Active Keys:
  ^ -increment
  v -decrement
CAL-exit, no save
CFM-save & exit
CLR-set to default
```

When in logging mode, an automatic printout will provide the following information for pH and mV:

```
Date      2004/01/01
Time      01:13:53
pH        7.01
mV        -23.3
°C        26.2
```

BATTERY REPLACEMENT

When the battery level becomes too low to ensure reliable readings, the meter automatically turns off.

Battery replacement must only take place in a safe area and using the battery type specified in this instruction manual.

To replace rundown batteries, remove the battery cover and substitute all four 1.5V AA alkaline batteries with new ones, while paying attention to the correct polarity.

Reattach and tighten the battery cover making sure that the gasket is in place.

Note: When batteries are removed, the meter can remember date & time for about 1 minute. After that, it will be necessary to set again date & time through the setup procedure.

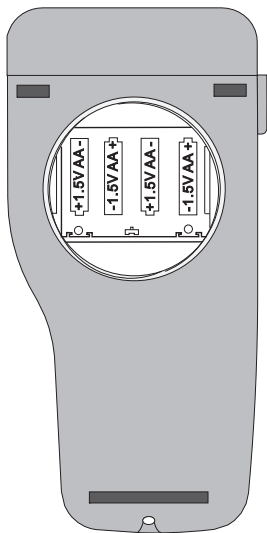

TEMPERATURE CALIBRATION

(for technical personnel only)

The instruments are factory calibrated for temperature. Adwa's temperature probes are interchangeable and no temperature calibration is needed when they are replaced.

If temperature measurements are not accurate, temperature new calibration should be performed.

For an accurate recalibration, contact your dealer or the nearest Adwa Customer Service Center, or follow the instructions below.

- Prepare a vessel containing ice and water, and another one containing hot water at approximately 50°C (122°F). Place insulation material around the vessels to minimize temperature drift.
- Use a calibrated thermometer with a resolution of 0.1 °C (or 0.1 °F) as reference thermometer. Connect the supplied **AD7662** temperature probe to the appropriate socket on the rear panel.
- With the instrument off, press and hold the CAL & up arrow keys, then power on the instrument. The “CAL” tag lights up and the secondary LCD shows 0.0 °C (or 32.0 °F). The primary LCD will display the measured temperature or “----”, if the reading is out of range.

- Immerse the temperature probe into the vessel with ice and water as close as possible to the reference thermometer. Allow a few seconds for probe thermal stabilization.
- Use the arrow keys to set the reading on the secondary LCD to that measured by the reference thermometer.



- When the reading is stable and close to the selected calibration point, the CFM tag starts blinking.
- Press CFM to confirm. The secondary LCD will display 50.0°C (or 122.0°F).



- Immerse the temperature probe into the second vessel as close as possible to the reference thermometer. Allow a few seconds for probe thermal stabilization.
- Use the arrow keys to set the reading on the secondary LCD to that of the hot water measured by the reference thermometer.
- When the reading is stable and close to the selected calibration point, the CFM tag starts blinking.

- Press CFM to confirm. The instrument returns to normal measurement mode.



Notes:

- If the reading is not close to the selected calibration point, the WRONG tag will blink. Change the temperature probe and restart calibration.
- Press CAL at any time to quit the procedure.

mV CALIBRATION (for technical personnel only)

The instruments are factory calibrated for mV range.

Adwa's ORP electrodes are interchangeable and no mV calibration is needed when they are replaced.

If measurements are not accurate, a mV recalibration should be performed.

For an accurate recalibration, contact your dealer or the nearest Adwa Customer Service Center, or follow the instructions below.

A two or three-point procedure can be performed at 0.0, 600.0 and 1800 mV.

- Attach a mV simulator with an accuracy of ± 0.1 mV to the BNC connector on the rear panel.
- With the instrument off, press and hold the CFM & STORE keys, then power on the instrument. The CAL tag lights up and the secondary LCD shows 0.0 mV.
- Set the simulator to 0.0 mV. When the reading is stable and close to the selected calibration point, the CFM tag starts blinking.
- Press CFM to confirm and the secondary LCD will display the second expected value (600.0 mV).
- Set the simulator to 600.0 mV. When the reading is stable and close to the selected calibration point, the CFM tag starts blinking.
- Press CFM to confirm. The secondary LCD will display the third expected value (1800 mV).
- Set the simulator to 1800.0 mV. When the reading is stable and close to the selected calibration point, the CFM tag starts blinking.
- Press CFM to confirm. The instrument returns to measurement mode.

Notes:

- If the reading is not close to the selected point, the WRONG tag will blink. Verify the calibration

conditions or contact your dealer if calibration can not be performed.

- To return to normal measurement mode, press CAL at any moment during calibration.
- If the calibration procedure is ended after the 600.0 mV point is confirmed, the meter returns to normal measurement mode and stores a 2-point calibration data.

PC INTERFACE (AD132 only)

Data can be transferred from the instrument to the PC using the **ADSW10** Windows® compatible software (optional).

ADSW10 also offers graphing and on-line help feature. Data can be exported to the most popular spreadsheet programs for further analysis.

To connect your instrument to a PC, use the **AD9551** optional Adwa cable. Make sure that the instrument is switched off and plug the cable to the instrument RS232 socket and to a serial port of your PC.

If not using the **AD9551** cable, communication between instrument and PC may be not possible, due to different RS232 connector configuration.

pH ELECTRODE CONDITIONING & MAINTENANCE

PREPARATION PROCEDURE

Remove the pH electrode protective cap. **DO NOT BE ALARMED IF SALT DEPOSITS ARE PRESENT.** This is normal with electrodes and they will disappear when rinsed with water.

During transport, tiny bubbles of air may form inside the glass bulb affecting proper functioning of the electrode. These bubbles can be removed by “shaking down” the electrode as you would do with a glass thermometer.

If the bulb and/or junction are dry, soak the electrode in **AD70300** storage solution for at least one hour.

STORAGE PROCEDURE

To minimize clogging and assure a quick response time, the glass bulb and the junction of the pH electrode should be kept moist and not allowed to dry out.

Replace the solution in the protective cap with a few drops of **AD70300** storage solution .

NEVER STORE THE ELECTRODE IN DISTILLED OR DEIONIZED WATER.

PERIODIC MAINTENANCE

Inspect electrode and cable. The cable used for connection to the instrument must be intact and there must be no points of broken insulation on the cable or cracks on the electrode stem or bulb. Connectors must be perfectly clean and dry. If any scratches or cracks are present, replace the electrode. Rinse off any salt deposits with water.

CLEANING PROCEDURE

Soak in **AD7061** general cleaning solution for approximately 30 minutes.

IMPORTANT: After performing any of the cleaning procedures, rinse the electrode thoroughly with **AD7000**, refill the reference chamber with fresh electrolyte and soak the electrode in **AD70300** storage solution for at least 1 hour before taking measurements.

TROUBLESHOOTING GUIDE

SYMPTOMS	PROBLEM	SOLUTION
Slow response/ excessive drift.	Dirty pH electrode.	Soak in AD7000 solution for 30 minutes and then clean the electrode.
Readings fluctuate up and down (noise).	Clogged/dirty junction. Low electrolyte level (for refillable electrodes only).	Clean the electrode. Refill with fresh solution (for refillable electrodes only).
Only blinking dashes during pH measurements.	Out of range in the pH scale.	Make sure the pH sample is in the specified range. Calibrate. Check electrolyte level and general state of the electrode.
Blinking reading during measurements.	Reading out of range or electrode not connected.	Check sample or connect electrode.
Out of range in the mV scale.	Dry membrane/ junction.	Soak in AD70300 storage solution for 1 h.

SYMPTOMS	PROBLEM	SOLUTION
The meter does not work with temperature probe.	Out of order temperature probe.	Replace the probe.
The meter fails to calibrate or gives faulty readings.	Broken or out of order pH electrode.	Replace the electrode.
Explicit warnings are displayed during pH calibration.	Dirty/broken pH electrode, contaminated reference or buffers.	Follow displayed instructions.
At start-up the meter displays all LCD permanently.	One of the keys is blocked.	Check the keyboard or contact the vendor.
“Prn Error” error message displayed.	Printer error.	Turn the meter off and then turn it on. If the error persist, contact your dealer.
“Err xx” error message displayed.	Internal error.	Turn the meter off and then turn it on. If the error persist, contact your dealer.

ELECTRODES, PROBES AND SOLUTIONS

- AD1230B** pH electrode with Epoxy body, tip protection bottle, BNC connector with protection sleeve and 1 m cable
- AD3230B** ORP electrode with Epoxy body, tip protection bottle, BNC connector with protection sleeve and 1 m cable
- AD7662** Stainless steel temperature probe with 1 m cable.
- AD70004P** pH 4.01 buffer solution, 20 ml sachet, 25 pcs.
- AD7004** pH 4.01 buffer solution, 230 ml bottle
- AD70007P** pH 7.01 buffer solution, 20 ml sachet, 25 pcs.
- AD7007** pH 7.01 buffer solution, 230 ml bottle
- AD70010P** pH 10.01 buffer solution, 20 ml sachet, 25 pcs.
- AD7010** pH 10.01 buffer solution, 230 ml bottle
- AD7061** Electrode cleaning solution, 230 ml bottle
- AD70300** Electrode storage solution, 230 ml bottle
- AD70000P** Electrode rinsing solution, 20 ml sachet, 25 pcs.
- AD7000** Electrode rinsing solution, 230 ml bottle
- AD9551** Serial communication cable, 5 to 9 pins