

unidirectional pump - series XV

STANDARD EUROPEAN PUMP
 ø25.4 FLANGE - TAPER SHAFT

XV-1P

X 1 P 25 02 F B B A

Series	X	series XV
Group	1	group 1
Category	P	unidirectional pump
Displacement	25	3.8
Flange	02	Ø25.4 STANDARD EUROPEAN right rotation
Shaft	F	CO001 - Tapered 1:8 - ø10 - M7x1 - key thk.2.4
Body	IN	inlet - 3/8" GAS
	OUT	outlet - 3/8" GAS
Cover	A	standard

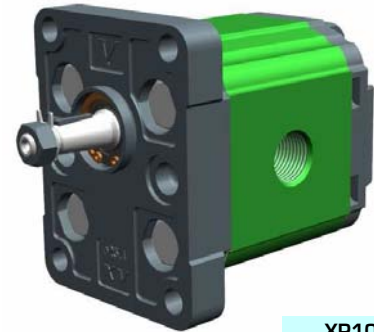

XP105

Technical data table

TYPE	Displacement cm3/rev	Max. Pressure		CODE			
		P1 bar	P3 bar	Left rotation		Right rotation	
XV-1P/0.9	0,91	240	280	X 1 P 16 01	F B B A	X 1 P 16 02	F B B A
XV-1P/1.2	1,17	250	290	X 1 P 17 01	F B B A	X 1 P 17 02	F B B A
XV-1P/1.7	1,56	250	290	X 1 P 18 01	F B B A	X 1 P 18 02	F B B A
XV-1P/2.2	2,08	250	290	X 1 P 20 01	F B B A	X 1 P 20 02	F B B A
XV-1P/2.6	2,60	250	300	X 1 P 21 01	F B B A	X 1 P 21 02	F B B A
XV-1P/3.2	3,12	250	300	X 1 P 23 01	F B B A	X 1 P 23 02	F B B A
XV-1P/3.8	3,64	250	300	X 1 P 25 01	F B B A	X 1 P 25 02	F B B A
XV-1P/4.3	4,16	250	300	X 1 P 27 01	F B B A	X 1 P 27 02	F B B A
XV-1P/4.9	4,94	250	300	X 1 P 29 01	F B B A	X 1 P 29 02	F B B A
XV-1P/5.9	5,85	250	300	X 1 P 31 01	F B B A	X 1 P 31 02	F B B A
XV-1P/6.5	6,50	250	300	X 1 P 32 01	F B B A	X 1 P 32 02	F B B A
XV-1P/7.8	7,54	220	260	X 1 P 34 01	F B B A	X 1 P 34 02	F B B A
XV-1P/9.8	9,88	190	230	X 1 P 36 01	F B B A	X 1 P 36 02	F B B A

P1) Max. working pressure - P3) Max. peak pressure

For heavy-duty applications, it is recommended to check the admissible torque of the shaft

Dimensions table

TYPE	Weight kg	A	B	C	D	
		mm	mm	mm	IN	OUT
XV-1P/0.9	0,950	78,1	37,3	66,1	3/8" BSPP	3/8" BSPP
XV-1P/1.2	0,970	79,0	37,8	67,0	3/8" BSPP	3/8" BSPP
XV-1P/1.7	1,010	80,5	38,5	68,5	3/8" BSPP	3/8" BSPP
XV-1P/2.2	1,030	82,5	39,5	70,5	3/8" BSPP	3/8" BSPP
XV-1P/2.6	1,060	84,5	40,5	72,5	3/8" BSPP	3/8" BSPP
XV-1P/3.2	1,090	86,5	41,5	74,5	3/8" BSPP	3/8" BSPP
XV-1P/3.8	1,120	88,5	42,5	76,5	3/8" BSPP	3/8" BSPP
XV-1P/4.3	1,170	90,5	43,5	78,5	3/8" BSPP	3/8" BSPP
XV-1P/4.9	1,200	93,5	45,0	81,5	3/8" BSPP	3/8" BSPP
XV-1P/5.9	1,260	97,0	46,8	85,0	3/8" BSPP	3/8" BSPP
XV-1P/6.5	1,300	98,5	48,0	86,5	3/8" BSPP	3/8" BSPP
XV-1P/7.8	1,360	103,5	50,0	91,5	3/8" BSPP	3/8" BSPP
XV-1P/9.8	1,500	112,5	54,5	100,5	3/8" BSPP	3/8" BSPP

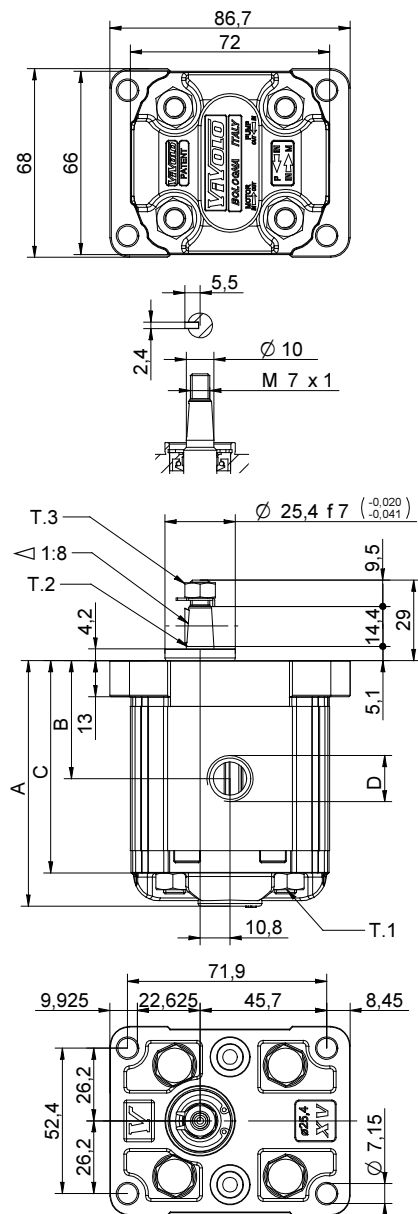

26/08/04 XP105ZFBBAff

T.1 = 24.5÷29.4 [Nm] - screw tightening torque M8

T.3 = 11.5 [Nm] - torque wrench setting 11

T.2 = 43 [Nm] - admissible shaft torque (N.B. When choosing a shaft, always check the admissible torque).

Table of variations

XV-1P

ø25.4 FLANGE

ø25.4 FLANGE				Shaft				Cover			
Left rotation		Right rotation						Left rotation		Right rotation	
	01		02	CO001 - Tapered T.2 = 43 [Nm]		CF002 - Milled shank T.2 = 13.8 [Nm]					A
	03		04	SCF04 - Splined T.2 = 22.6 [Nm] m=1.6 Z=6 DIN 5482 - 12x9		SCF02 - Splined T.2 = 42.8 [Nm] m=0.75 Z=15					B
	05		06	SCF01 - Splined T.2 = 42.8 [Nm] m=0.75 Z=15		SCF03 - Splined T.2 = 42.8 [Nm] m=0.75 Z=15					C
	07		08								D

Displacement	
TYPE	CODE
XV-1P/0.9	16
XV-1P/1.2	17
XV-1P/1.7	18
XV-1P/2.2	20
XV-1P/2.6	21
XV-1P/3.2	23
XV-1P/3.8	25
XV-1P/4.3	27
XV-1P/4.9	29
XV-1P/5.9	31
XV-1P/6.5	32
XV-1P/7.8	34
XV-1P/9.8	36

Standard bodies							
Displacement cm3/rev	Standard threads						
	0.9	I - I	B - B	J - J	B - Z	Z - Z	G - F
1.2	I - I	B - B	J - J	B - Z	Z - Z	G - F	
1.7	I - I	B - B	J - J	B - Z	Z - Z	G - F	
2.2	I - I	B - B	J - J	B - Z	Z - Z	G - F	
2.6	I - I	B - B	J - J	B - Z	Z - Z	G - F	
3.2	I - I	B - B	J - J	B - Z	Z - Z	G - F	
3.8	I - I	B - B	J - J	B - Z	Z - Z	G - F	
4.3	I - I	B - B	J - J	B - Z	Z - Z	G - F	
4.9	I - I	B - B	J - J	B - Z	Z - Z	G - F	
5.9	I - I	B - B	J - J	B - Z	Z - Z	G - F	
6.5	I - I	B - B	J - J	B - Z	Z - Z	G - F	
7.8	I - I	B - B	J - J	B - Z	Z - Z	G - F	
9.8	I - I	B - B	J - J	B - Z	Z - Z	G - F	

Table showing standard flange and thread combinations available in stock

		N
Internal drainage		
		O
External drainage		

Body (threads/flanges)							
	A		B		C		D
	E		F		G		
	H		I		J	Closed Body	Z