

EIPC3 EIPC5 EIPC6

INTERNAL GEAR PUMPS



- new Generation EIPC
new technology
- up to 320 bar
- industrial version
- aluminium housing
- noise-optimized
- multi-flow-pumps
with common
suction port



Internal gear pump Type EIPC3 for industrial applications with constant displacement volume



EIPC3

Characteristics

- Internal gear pump with axial and radial gap compensation
- Radial compensation with segments
- Suction and pressure port radial
- Field of application: Industrial hydraulic
- Low noise
- Long time life
- Low pulsation (pressure pulsation ~ 2 %)
- Multi flow combinations

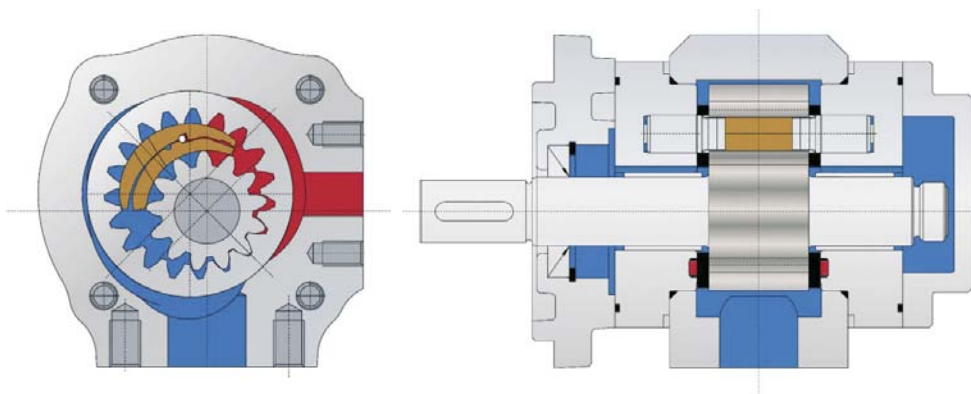

Technical Data:

Rated Size NG	020	025	032	040	050	064
Spec. volume V_{th} [cm ³ /rev] ^{***}	20.0	24.8	32.1	40.1	50.3	64.4
Continuous operating pressure [bar] ^{**}	250					
Peak operating pressure [bar] max. 10 sec 15 % dutycycle	320		300		280	280
Cut-in pressure peak [bar] ^{**}	350		325		300	300
Max. speed [min ⁻¹]	3,600	3,200	3,000	2,500	1,800	1,800
Nominal speed [min ⁻¹]	200 – 3,600	200 – 3,200	200 – 3,000	100 – 2,500	100 – 1,800	100 – 1,800
Operating viscosity [mm ² /s]	10 – 300					
Starting viscosity [mm ² /s]	2,000					
Operating temperature [°C]	-20 to +100					
Operating medium	HL – HLP DIN 51 524 part 1/2					
Max. medium temperature [°C]	120					
Min. medium temperature [°C]	-40					
Max. ambient temperature [°C]	80					
Min. ambient temperature [°C]	-40					
Max. admission pressure (intake side) [bar]	2 bar absolute					
Min. admission pressure (intake side) [bar]	0.8 bar absolute (Start 0.6)					
Weight appr. [kg]	8.3	8.6	9.2	9.8	10.5	11,5
Degree of filtration	Class 20/18/15 due to ISO 4406					

Efficiency vol	93	93	94	95	95	95
Efficiency η_{hm}	91	92	92	93	93	93
Pump noise* (measured in sound chamber) dB[A]	62	63	64	65	66	66
	n = 1,450	$\Delta p = 250$ bar		T = 50 °C		Medium: HLP 46

* Measured in anechoic room of Eckerle Hydraulic Division; Axial microphone distance 1.0 m

** For acceptable pressure at 400-1.800 rpm. Further rpm on request.

*** Due to manufacturing tolerances the displacement volume could vary.

Internal gear pump Type EIPC5 for industrial applications with constant displacement volume



EIPC5

Characteristics

- Internal gear pump with axial and radial gap compensation
- Radial compensation with segments
- Suction and pressure port radial
- Field of application: Industrial hydraulic
- Low noise
- Long time life
- Low pulsation (pressure pulsation ~ 2 %)
- Multi flow combinations

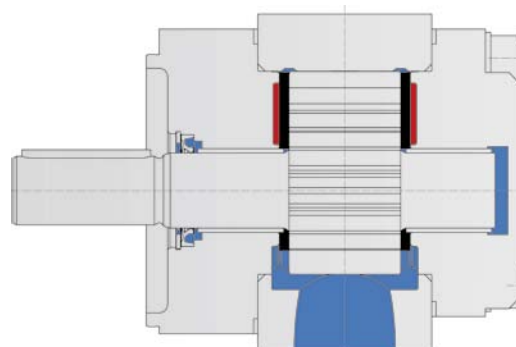
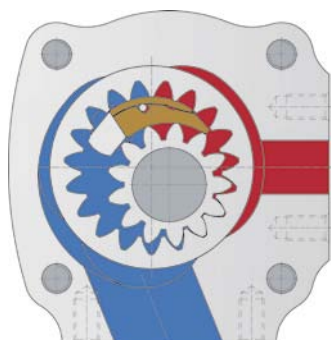

Technical Data:

Rated Size NG	064	080	100
Spec. volume V_{th} [cm ³ /rev] ^{***}	65,3	80,4	100,5
Continuous operating pressure [bar] ^{**}	210		
Peak operating pressure [bar] max. 10 sec 15 % dutycycle	230		
Cut-in pressure peak [bar] ^{**}	250		
Max. speed [min ⁻¹]	3,000	3,000	2,500
Nominal speed [min ⁻¹]	100 – 3,000	100 – 3,000	100 – 2,500
Operating viscosity [mm ² /s]	10 – 300		
Starting viscosity [mm ² /s]	2,000		
Operating temperature [°C]	-20 to +100		
Operating medium	HL – HLP DIN 51 524 part 1/2		
Max. medium temperature [°C]	120		
Min. medium temperature [°C]	-40		
Max. ambient temperature [°C]	80		
Min. ambient temperature [°C]	-40		
Max. admission pressure (intake side) [bar]	2 bar absolute		
Min. admission pressure (intake side) [bar]	0.8 bar absolute (Start 0.6)		
Weight appr. [kg]	11.5	13.0	13.5
Degree of filtration	Class 20/18/15 due to ISO 4406		

Efficiency η_{vol}	94	95	95
Efficiency η_{hm}	92	93	93
Pump noise* (measured in sound chamber) dB[A]	69	70	71
	n = 1,450	$\Delta p = 210$ bar	T = 50 °C
			Medium: HLP 46

* Measured in anechoic room of Eckerle Hydraulic Division; Axial microphone distance 1.0 m

** For acceptable pressure at 400-1.800 rpm. Further rpm on request.

*** Due to manufacturing tolerances the displacement volume could vary.

Internal gear pump Type EIPC6 for industrial applications with constant displacement volume



EIPC6

Characteristics

- Internal gear pump with axial and radial gap compensation
- Radial compensation with segments
- Suction and pressure port radial
- Field of application: Industrial hydraulic
- Low noise
- Long time life
- Low pulsation (pressure pulsation ~ 2 %)
- Multi flow combinations

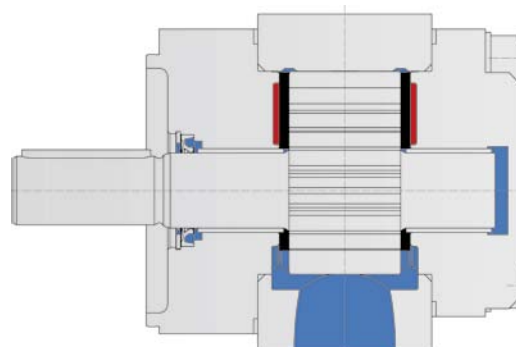
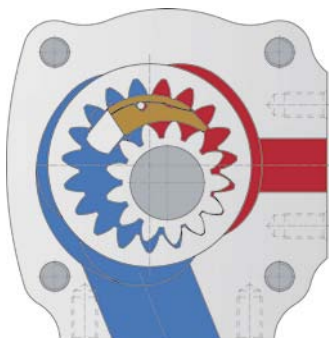

Technical Data:

Rated Size NG	125	160	200	250
Spec. volume V_{th} [cm ³ /rev] ^{***}	125.7	160.1	200.9	249.9
Continuous operating pressure [bar] ^{**}	250		160	140
Peak operating pressure [bar] max. 10 sec 15 % dutycycle	280		170	150
Cut-in pressure peak [bar] ^{**}	300		180	160
Max. speed [min ⁻¹]	2,800	2,200		
Nominal speed [min ⁻¹] ^{****}	400 – 2,500	400 – 2,000		
Operating viscosity [mm ² /s]	10 – 300			
Starting viscosity [mm ² /s]	2,000			
Operating temperature [°C]	-20 to +100			
Operating medium	HL – HLP DIN 51 524			
Max. medium temperature [°C]	80			
Min. medium temperature [°C]	-20			
Max. ambient temperature [°C]	80			
Min. ambient temperature [°C]	-20			
Max. admission pressure (intake side) [bar]	2 bar absolute			
Min. admission pressure (intake side) [bar]	0.8 bar absolute			
Weight appr. [kg]	27,5	30	43	54
Degree of filtration	Class 20/18/15 due to ISO 4406			

Efficiency η_{vol}	94	94	93	93
Efficiency η_{hm}	90		91	
Pump noise* (measured in sound chamber) dB[A]	76	77	77	78
	n = 1.450	$\Delta p = 250$ bar (160 bar at size 200 and 250)	T = 50 °C	Medium: HLP 46

* Measured in anechoic room of Eckerle Hydraulic Division; Axial microphone distance 1.0 m

** For acceptable pressure at 400-1.800 rpm. Further rpm on request.

*** Due to manufacturing tolerances the displacement volume could vary.

**** Further rpm on request.



Pump with SAE-2-B-hole flange and cylindrical shaft

Order example: EIPC3-__RA23-1X

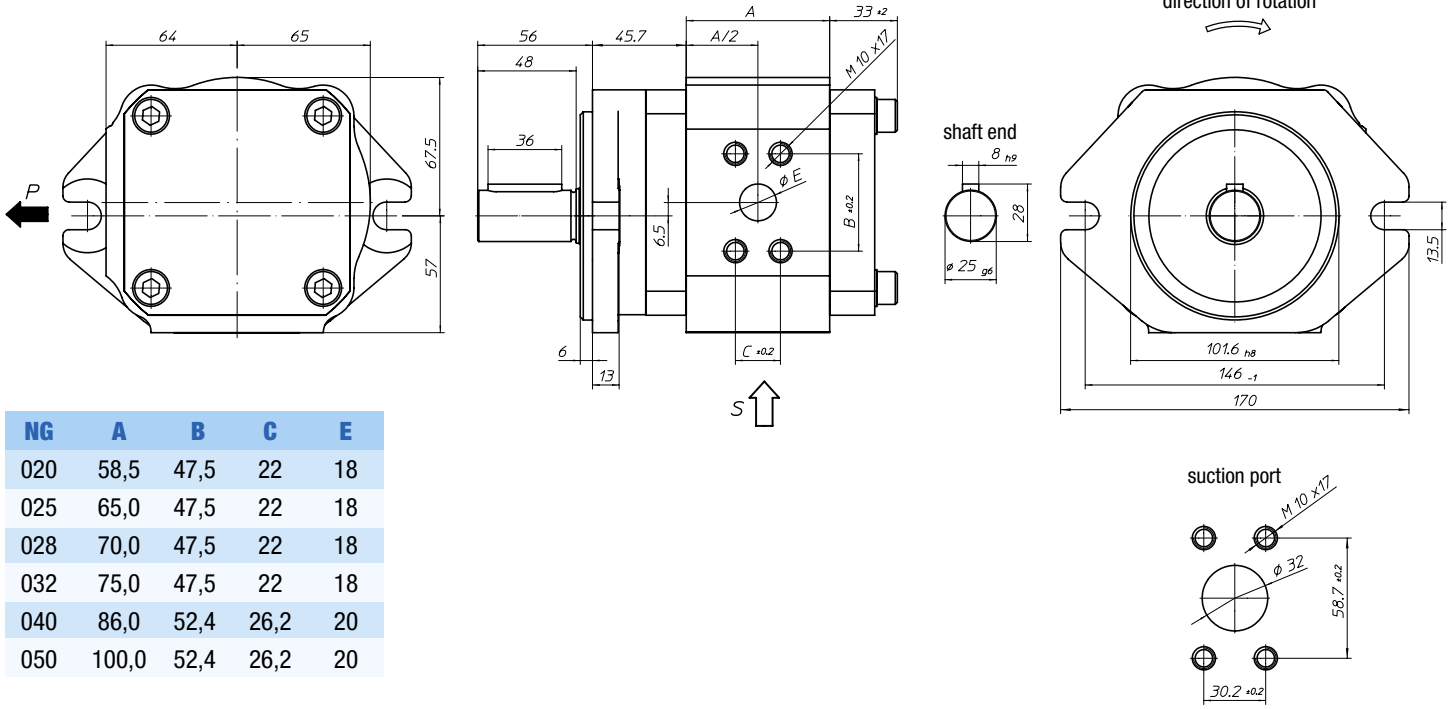

NG	A	B	C	E
020	58,5	47,5	22	18
025	65,0	47,5	22	18
028	70,0	47,5	22	18
032	75,0	47,5	22	18
040	86,0	52,4	26,2	20
050	100,0	52,4	26,2	20

Pump with SAE-2-B-hole flange and spline shaft

Order example: EIPC3-__RB23-1X

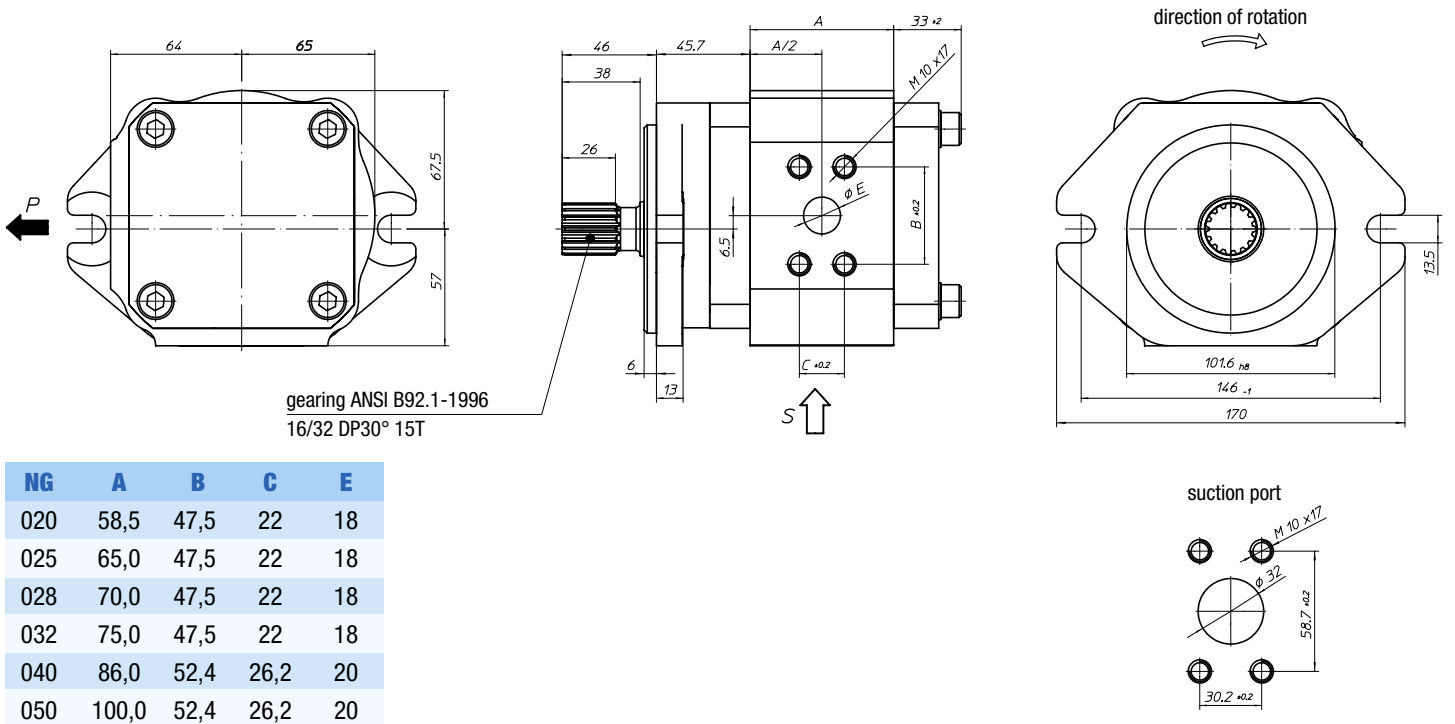

NG	A	B	C	E
020	58,5	47,5	22	18
025	65,0	47,5	22	18
028	70,0	47,5	22	18
032	75,0	47,5	22	18
040	86,0	52,4	26,2	20
050	100,0	52,4	26,2	20



Pump with SAE-B-2-hole flange and cylindrical shaft

Order example: EIPC3-__RK23-1X

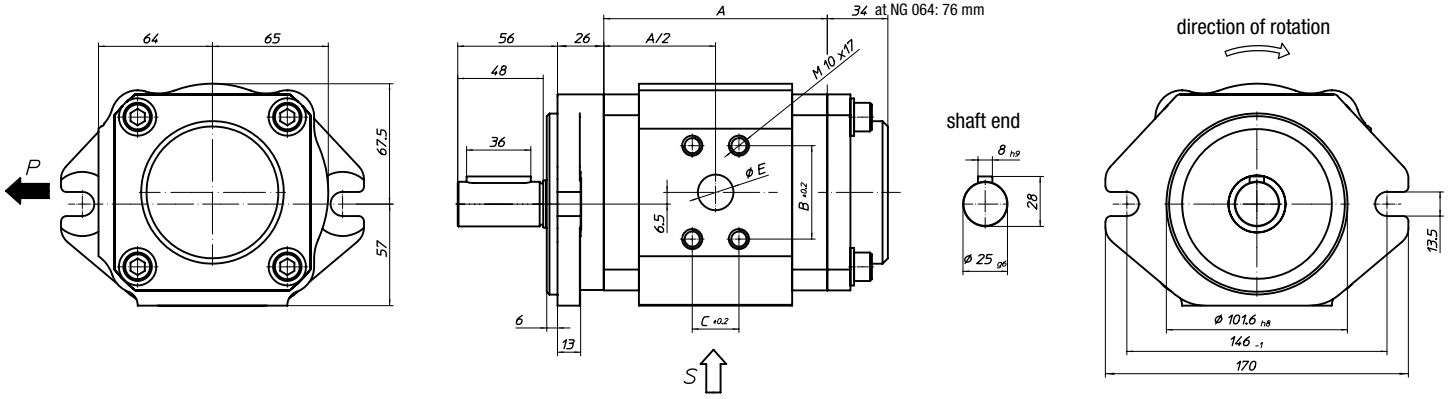

NG	A	B	C	E
020	97.9	47.5	22	18
025	104.4	47.5	22	18
032	114.4	47.5	22	18
040	125.4	52.4	26.2	20
050	139.4	52.4	26.2	20
064	139.4	52.4	26.2	20

Double Pump with SAE-B-2-hole flange and cylindrical shaft

Order example: EIPC3-__RK20-1X+
EIPC3-__RP30-1X

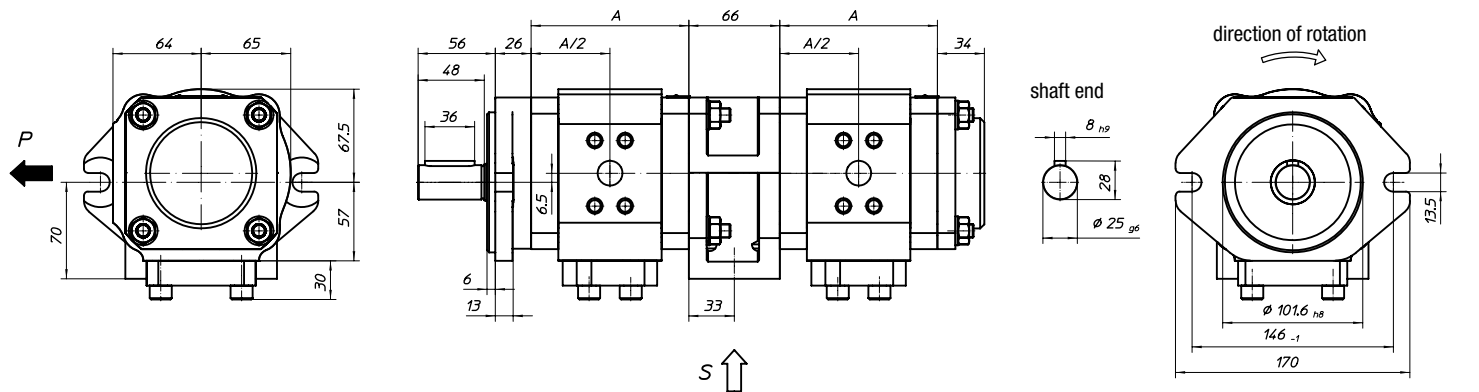

NG	A
020	97.9
025	104.4
032	114.4
040	125.4
050	139.4

Pressure connections see single pump

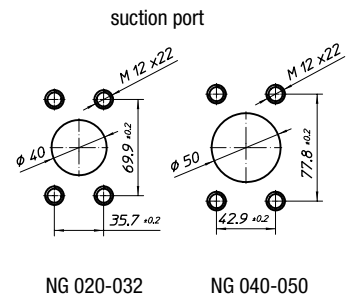



Pump with SAE-C-2-hole flange and cylindrical shaft

Order example: EIPC5-__ _RA23-1X

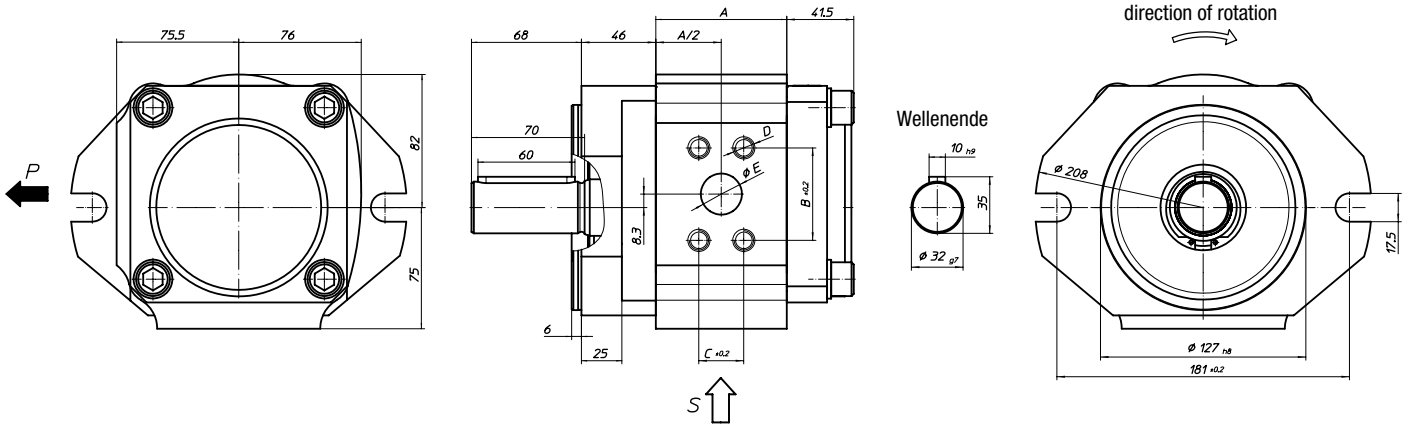

NG	A	B*	C*	D	E	L**	M**	N
064	81	57.2	27.8	M12x22	25,4	77.8	42.9	47.2
080	93	66.7	31.8	M14x24	31.8	77.8	42.9	47.2
100	109	66.7	31.8	M14x24	31.8	88.9	50.8	63.5

* Pressure port: SAE J518, high pressure series (code 62)
 ** Suction port: SAE J518, standard pressure series (code 61)

Pump with SAE-C-2-hole flange and spline shaft

Order example: EIPC5-__ _RB23-1X

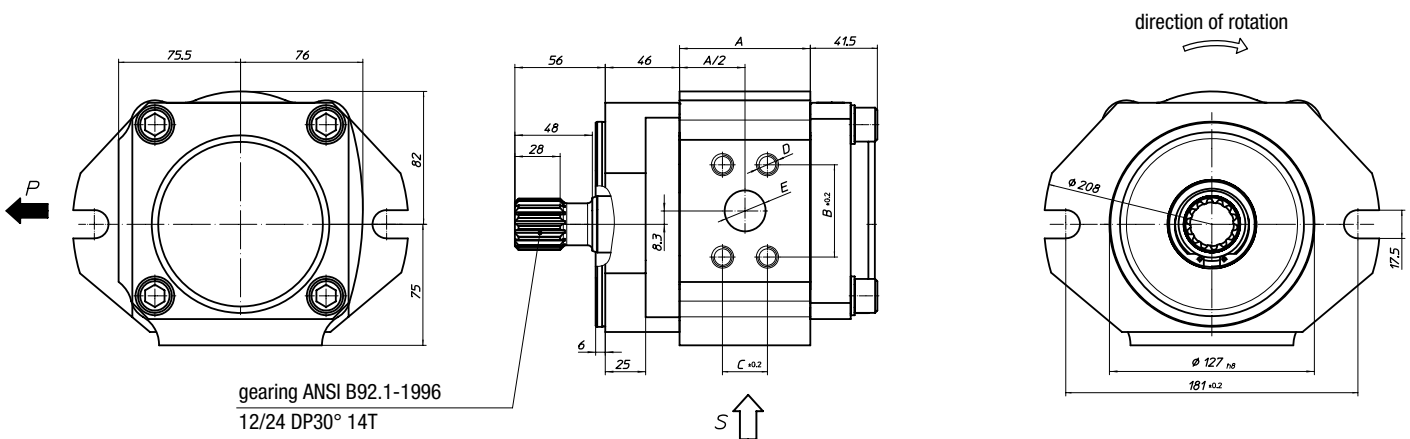

NG	A	B*	C*	D	E	L**	M**	N
064	81	57.2	27.8	M12x22	25.4	77.8	42.9	47,2
080	93	66.7	31.8	M14x24	31.8	77.8	42.9	47,2
100	109	66.7	31.8	M14x24	31.8	88.9	50.8	63,5

* Pressure port: SAE J518, high pressure series (code 62)
 ** Suction port: SAE J518, standard pressure series (code 61)



Pump with SAE-D-2-hole flange and cylindrical shaft

Order example: EIPC6-__ _RA23-1X

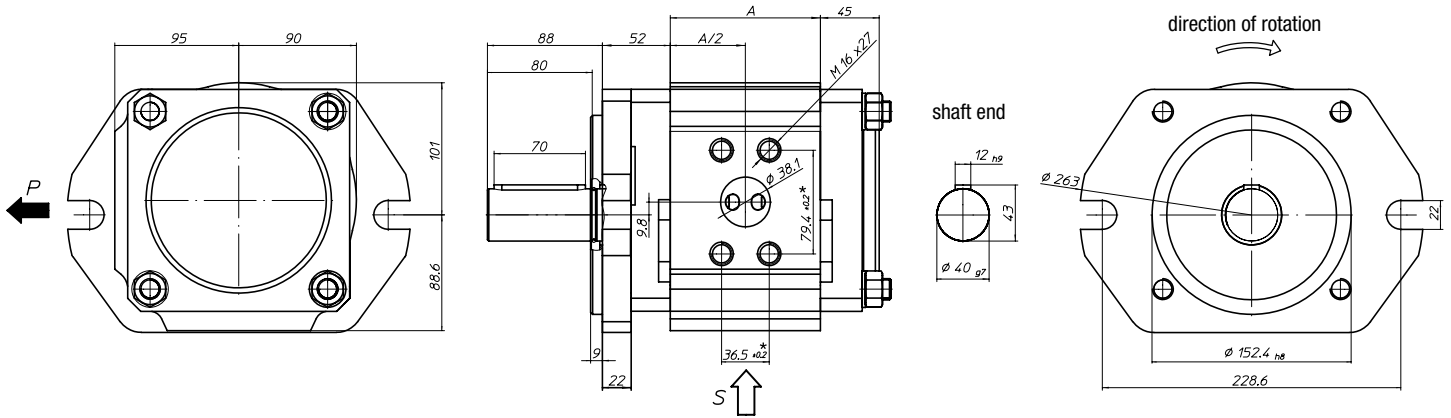

NG	A	L**	M**	N	P
125	115	88.9	50.8	63.5	M12x22
160	136	106.4	61.9	76.2	M16x25
200	161	120.7	69.9	88.9	M16x25
250	191	120.7	69.9	88.9	M16x25

* Pressure port: SAE J518, high pressure series (code 62)
 ** Suction port: SAE J518, standard pressure series (code 61)

Pump with SAE-D-2-hole flange and spline shaft

Order example: EIPC6-__ _RB23-1X

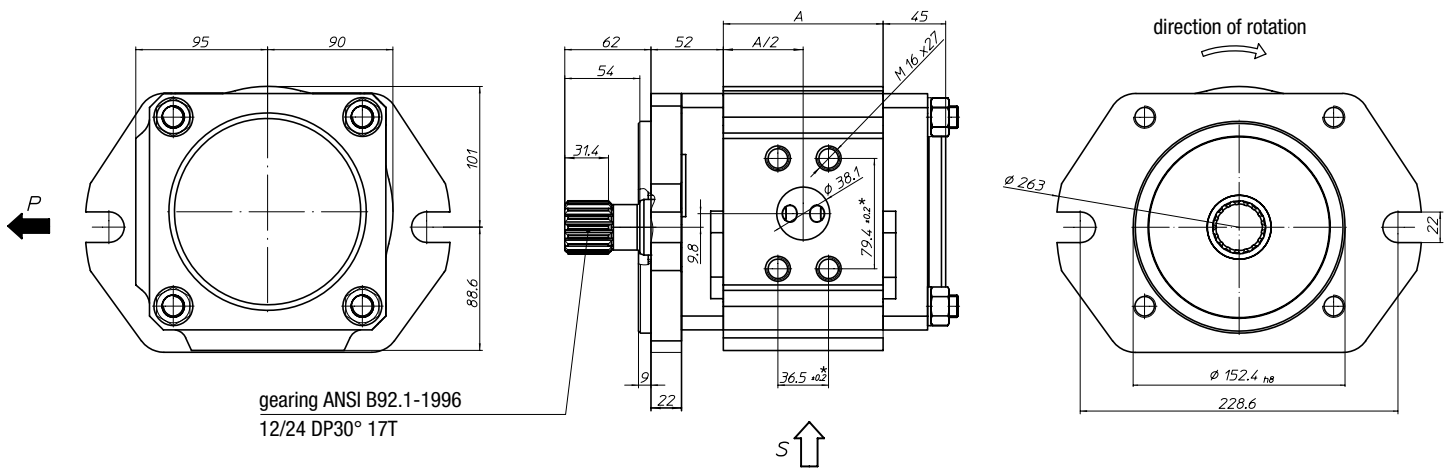

gearing ANSI B92.1-1996
 12/24 DP30° 17T

NG	A	L**	M**	N	P
125	115	88.9	50.8	63.5	M12x22
160	136	106.4	61.9	76.2	M16x25
200	161	120.7	69.9	88.9	M16x25
250	191	120.7	69.9	88.9	M16x25

* Pressure port: SAE J518, high pressure series (code 62)
 ** Suction port: SAE J518, standard pressure series (code 61)



SAE flange metric tapped



Version a

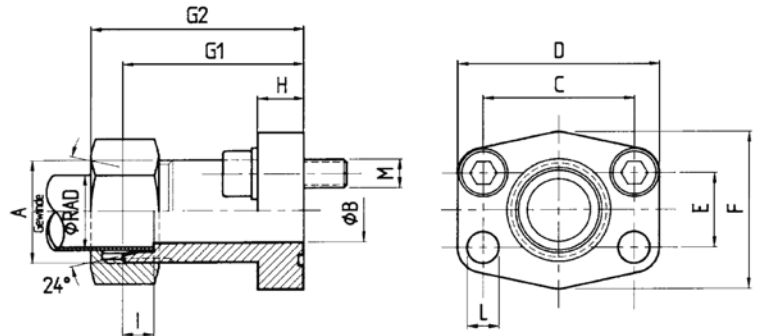

SAE pipe threaded flange



Version b

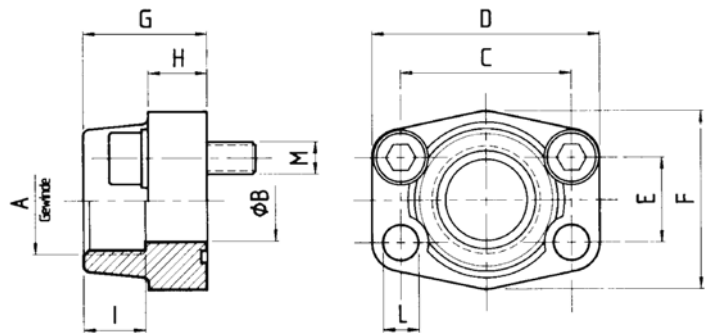

Nr.	Article number	Type	P _{max}	AD	A	B	C	D	E	F	G1	G2	H	I	L
1a	07 07 04 0030	AD15-SAE12M22x1,5	315	15	M22x1.5	12	38.1	54	17.5	46	52	60	13	7	9
1b	07 07 04 0026	EFG1/2-SAE12	350		G1/2"	13	38.1	54	17.5	46	36		19	19	9
2a	07 07 04 0031	AD22-SAE34M30x2	160	22	M30x2	19	47.5	65	22.2	50	60	69	14	7.5	11.5
2b	07 07 04 0027	EFG3/4-SAE34	350		G3/4"	19	47.5	65	22.2	50	36		18	19	11
3a	07 07 04 0032	AD28-SAE100M36x2	160	28	M36x2	24	52.4	70	26.2	55	63	72	16	7.5	11.5
3b	07 07 04 0028	EFG1-SAE100	315		G1"	25	52.4	70	26.2	55	38		18	22	11
4a	07 07 04 0033	AD35-SAE114M45x2	160	35	M45x2	29	58.7	79	30.2	68	65	76	14	10.5	11.5
4b	07 07 04 0029	EFG1 1/4-SAE114	250		G1 1/4"	32	58.7	79	30.2	68	41		21	22	11.5
5a	07 07 04 0037	AD42-SAE112M52x2	160	42	M52x2	36	69.9	94	35.7	78	70	82	16	11	13.5
5b	07 07 04 0034	EFG1 1/2-SAE112	200		G1 1/2"	38	69.9	94	35.7	78	45		25	24	13.5
6b	07 07 04 0036	EFG2-SAE200	200		G2"	51	77.8	102	42.9	90	45		25	30	13.5
7b	07 07 04 0041	EFG2 1/2-SAE212	160		G2 1/2"	63	88.9	114	50.8	105	50		25	30	13.5
8a	07 07 04 0042	AD30-SAE100M42x2HD	400	30	M42x2	25	57.2	81	27.8	70	82	95	24	13.5	13
9a	07 07 04 0043	AD38-SAE114M52x2HD	400	38	M52x2	32	79.4	113	36.5	95	96	111	30	16	17.5

Connecting flanges SAE for Double Pump EIPC3



EIPC

SAE Pressure- and Suction flange SAE J518C, ISO 6162

Type	Inlet	Nr.	Version		Outlet	Nr.	Version	
			a	b			a	b
EIPC3-020-032	1 1/4"	4	•	•	3/4"	2	•	•
EIPC3-040-064	1 1/4"	4	•	•	1"	3	•	•

Suction flange for Intermediate housing

Type	Inlet	Nr.	Version	
			a	b
EIPC3/3 bis NG0321	1/2"	5	•	•
EIPC3/3 ab NG040	2"	6		•

• = available



EIP C3-032 RK23 -1X SXXX

Special version number (not applicable with standard pumps or when the type key is unambiguous)

Revision code 1st number: Change of mounting dimensions
2nd number: Change of pump with same mounting dimensions

Intake and delivery connection 3: SAE-flange connections
0: suction port closed; common inlet
– other flanges on request –

Fastening flange 2: SAE/B 2-hole flange, centre-Ø 101.6 / at EIPC3
2: SAE/C 2-hole flange, centre-Ø 127 / at EIPC5
2: SAE/D 2-hole flange, centre-Ø 152,4 / at EIPC6
3: Direkt fixture
5: VDMA on demand
– other flanges on request –

Shaft end A: Cylindrical
K: Cylindrical with cone
B: SAE gear
L: SAE gear with cone
P: Cone tooth system on both sides
(cone = add-on facility for additional pumps to create multiple-flow pumps)

Sense of rotation R: Clockwise
L: Anticlockwise

Rated size, three digits

Overall size 3, 5 or 6

Type C: Industrial pump with aluminium housing

Eckerle internal gear pump

Order example

EIPC3-032 RK23-1X

for industrial applications
overall size 3 with 32.1 cm³/U
clockwise rotation
cylindrical shaft with cone
SAE/B-2-hole flange connection
SAE flange connection
revision code 1X