

TWO-LINE DISTRIBUTOR

DLDF, DLDF-P

APPLICATION

DLDF distributors are a lubricating element of two-line lubrication system applied for dosing lubricant into individual lubricated points. The distributors are applied for lubrication of various machines, machine groups and equipment, e.g. in metallurgy, mining industry, cement works, sugar factories, power engineering, metallurgical plants etc.

DLDF distributors are supplied in execution with regulation head, i.e. with possibility to adjust supplied lubricant dose and in execution DLDF-P without regulation head, i.e. with fixed lubricant dose. This fixed dose is selectable by using exchangeable regulation plugs in sizes 1.5 - 0.75 - 0.37 cm³/stroke/outlet.

Distributors DLDF and DLDF-P are supplied with various number of outlets - 1 to 8. Individual types and other series of two-line distributors (e.g. DLDA, DLDC, DLDD, ZVM) can be combined mutually in a central lubrication circuit, so a high variability of nominal doses can be reached and further can be adjusted during system operation.

DESCRIPTION

A distributor is based on a body in which 1 to 4 functional units are placed with respect to appropriate types. Every functional unit consists of a distributing piston (slider), delivery piston (dosing lubricant into the point to be lubricated), regulation heads, signalling pin (regulation rod), regulation screw and two outlets that can be provided with full outlet piping. Distributors DLDF-P are provided with an exchangeable plug instead of regulation head. The inlet piping is connected to the distributor through the complete inlet connection. There are two anchor holes for 6 mm diameter screws in the distributor body.

OPERATION

The two-line distributor is connected into the circuit of a two-line lubrication system. For a distributor to function, it is essential to alternate the pressure in pipe lines, which is provided by the working function of the two-line lubricating pump (e.g. Z2). When the lubricant is supplied into one branch, the distributing piston is shifted on into a limit position. The lubricant gets under the delivery piston by opening a connecting channel. The delivery piston moves into the other limit position and simultaneously forces out the lubricant through the interconnecting channel around the distributing piston into the outlet. The whole working cycle is repeated in the opposite direction after supplying the pressure to the other branch and relieving the first branch. Two strokes of a distributor are needed for the lubrication of all the lubricated points included in the two-line lubrication system. Nominal dose adjustment (only for type DLDF) is provided by means of an adjusting screw in the regulation head. By means of this adjusting screw the stroke of delivery piston is limited through the regulation rod. If the adjusting screw is fully tightened, the outlet is adjusted to minimum flow rate. An odd number of outlets is attained by plugging one of the functional unit outlets and taking out its distribution screw (with distributors already supplied with an odd number of outlets made by supplier). In this case a doubled nominal dose is supplied into the opposite outlet, which can be adjusted by an adjusting screw according to requirements. This fact allows the variability of nominal doses of lubricant from the outlet to be extended. If there is a requirement for much more different nominal doses of lubricant from the outlets of one DLDF distributor, the dose can be doubled or tripled by using connecting bridges. This special requirement must be arranged with the supplier. On consultation with the supplier, a DLDF distributor can be fitted with an electric signalling device. An individual outlet can be furnished with a switch that would allow a permanent control of the supplied lubricant into the lubricated point.

SERVICE AND MAINTENANCE

DLDF distributors are mounted in any position. During the assembly it is advisable to ensure easy access to the adjusting screws for the adjustment of nominal dose. The distributors are fixed directly to the machine foundation by means of M6x50 mm screws or by a welded-on clamp. The clamp and anchor bolts are not part of the delivery.

After the distributor is mounted to the chosen place the inlet piping is connected and the lubricant passed through. The connection of the distributors to the piping should always be made in the same way, i.e. the same inlet piping, e.g. upper one, should be connected to the same pipe line. The distributor is adjusted for maximum dose. When the lubricant leaves the outlets without air bubbles, the outlet piping can be connected. It is recommended to adjust the doses only during operation. The distributors require no further service except to check connections for leakage from time to time.

TECHNICAL DATA

Maximum working pressure		400 bar
Working pressure		350 bar
Minimum working pressure		10 bar
Nominal output		1.5 cm ³ /stroke/outlet
Regulating range of nominal output DLDF		0 to 100%
Fixed dose DLDF-P	plug 1/1	1.50 cm ³ /stroke/outlet
	plug 1/2	0.75 cm ³ /stroke/outlet
	plug 1/4	0.37 cm ³ /stroke/outlet
Number of outlets	DLDF 2-1	1
	DLDF 2-2	2
	DLDF 4-3	3
	DLDF 4-4	4
	DLDF 6-5	5
	DLDF 6-6	6
	DLDF 8-7	7
	DLDF 8-8	8
Inlet pipe union		G3/8"
Outlet pipe union		G1/4"
Lubricant	grease	max. NLGI-2
	oil	min. 50 mm ² /sec.
Temperature of working environment		-25 to 80°C
Weight		1.6 to 3.6 kg (depending on execution)

NOTE:

It is possible to supply two-line distributors DLDF, DLDF-P with complete assembled inlet and outlet connections according to customer's request. It is necessary to indicate the specification in order or a specification on packing list might be used (see User's guide).

DLDF 2-2

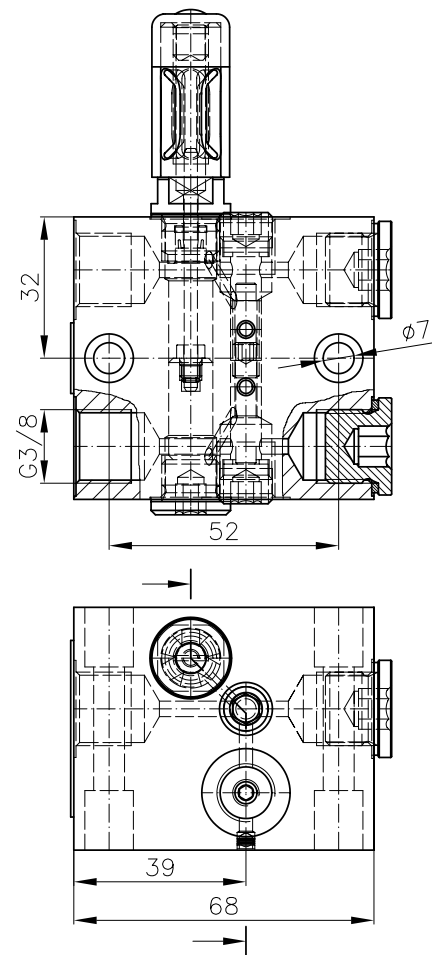

DLDF 4-4

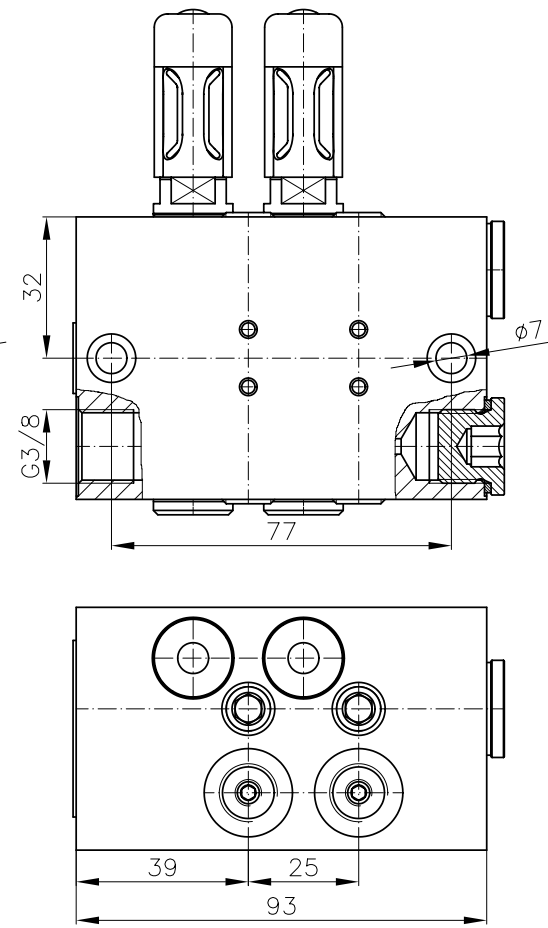

DLDF 6-6

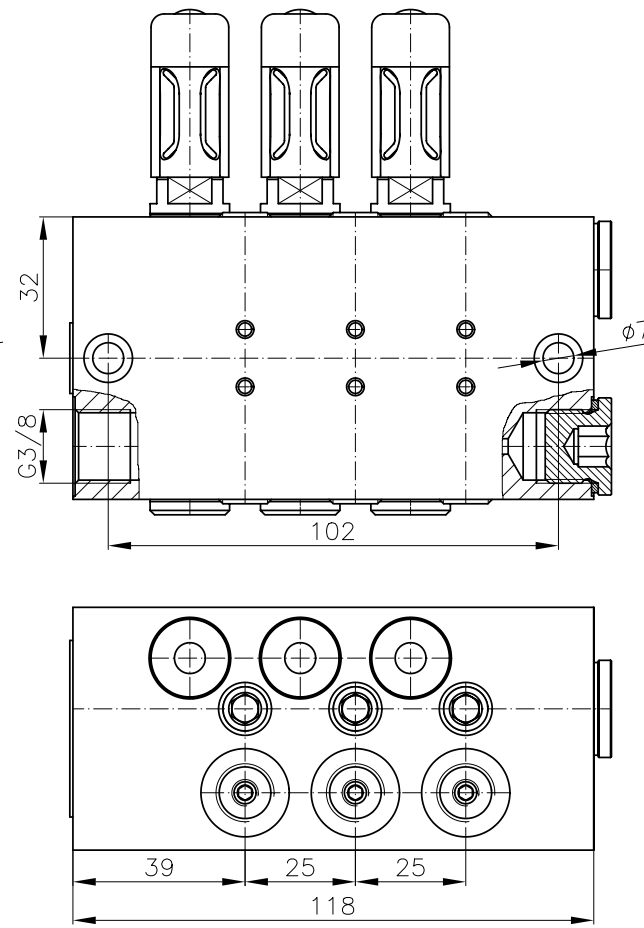

DLDF 8-8

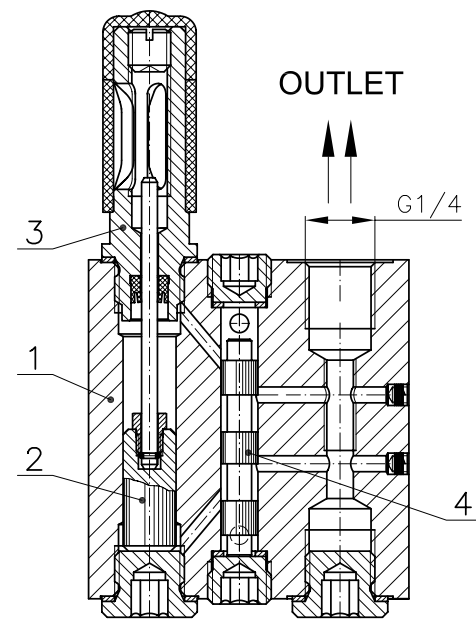
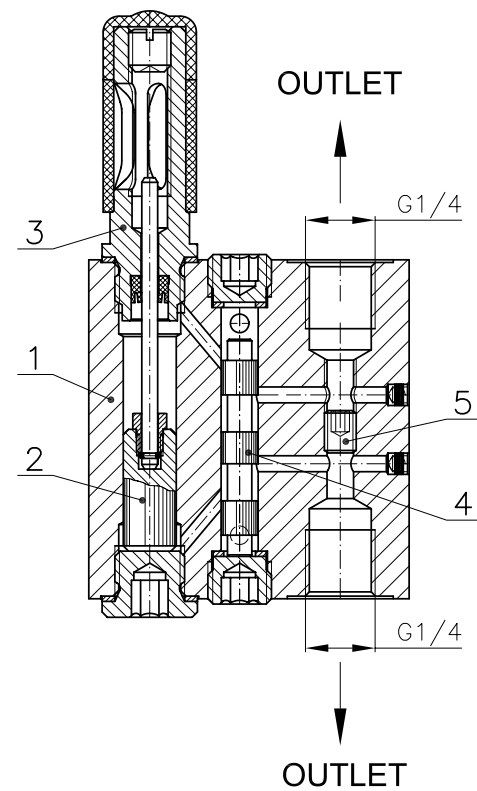
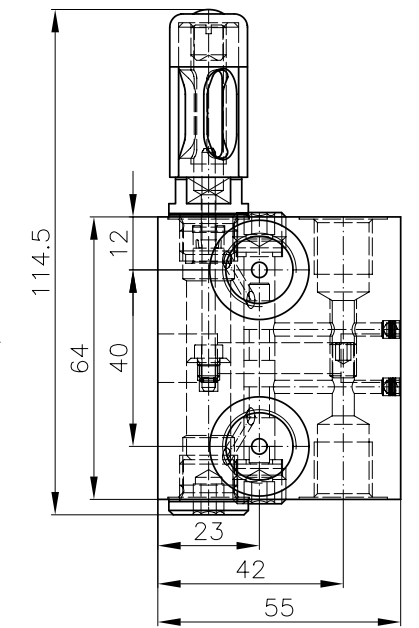
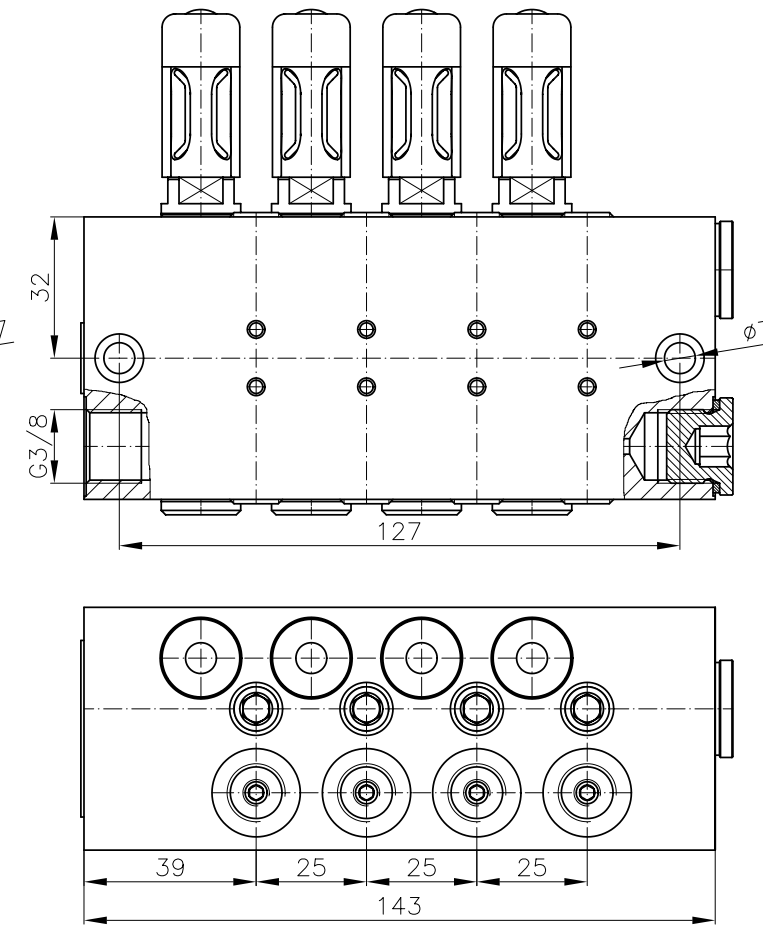

Type	Code
DLDF 2-2	9 52 0654
DLDF 4-4	9 52 0655
DLDF 6-6	9 52 0656
DLDF 8-8	9 52 0657
DLDF 2-1	9 52 0686
DLDF 4-3	9 52 0687
DLDF 6-5	9 52 0688
DLDF 8-7	9 52 0689

Pos	Name
1	Distributor body
2	Metering piston
3	Regulatory head
4	Servo piston
5	Blocking screw

Name	TWO-LINE DISTRIBUTOR	
Type	DLDF	
Code		

DLDF-P 2-2

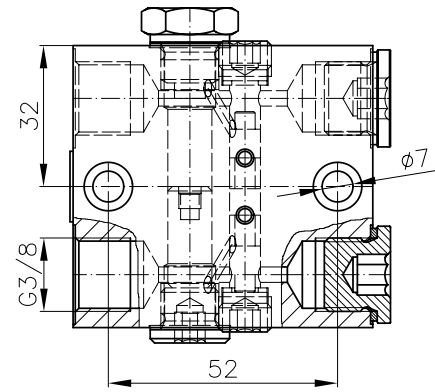

DLDF-P 4-4

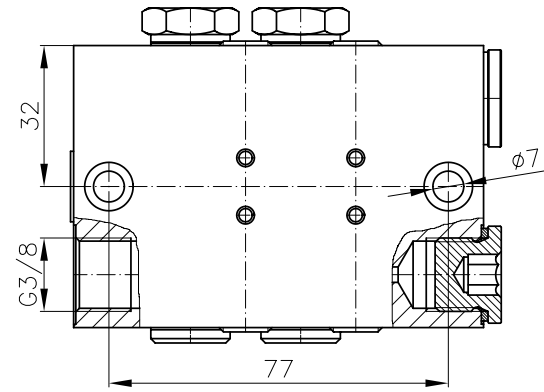

DLDF-P 6-6

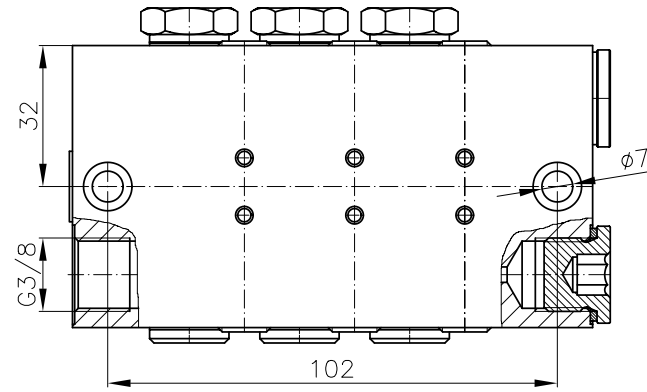

DLDF-P 8-8

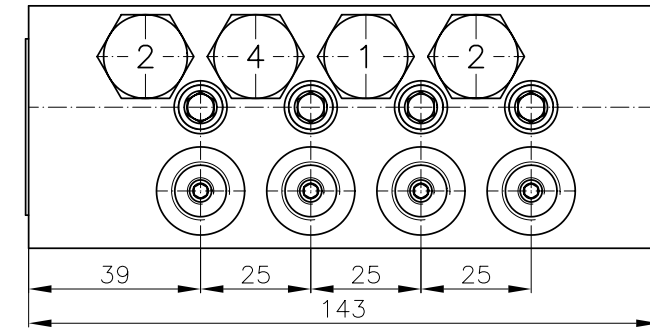
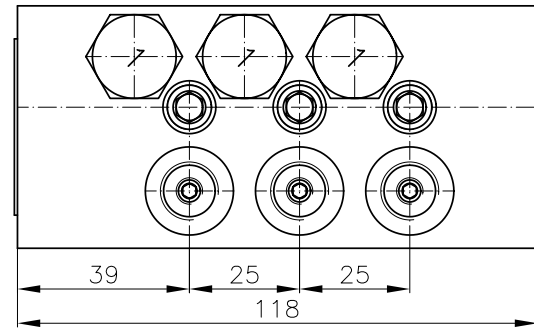
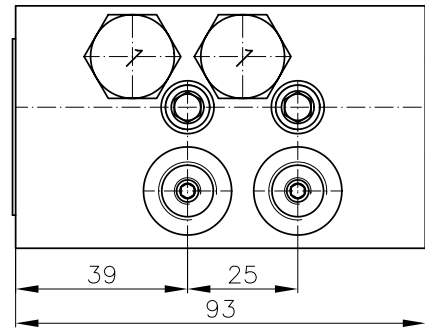
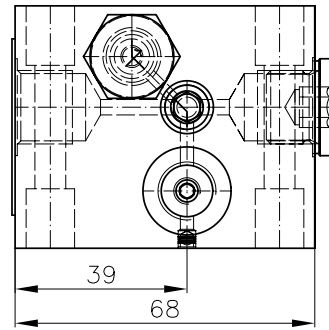
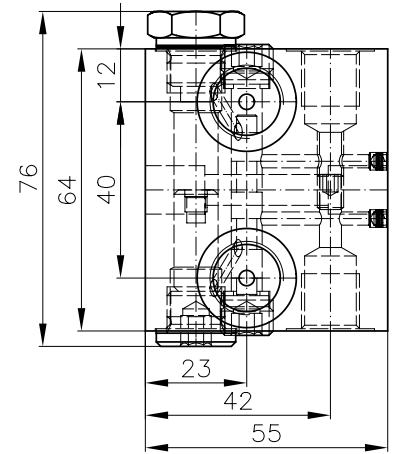
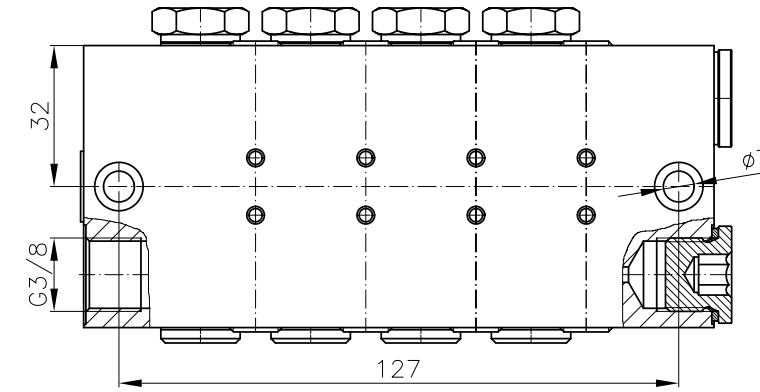

METERING SCREW (EXCHANGEABLE PLUG)

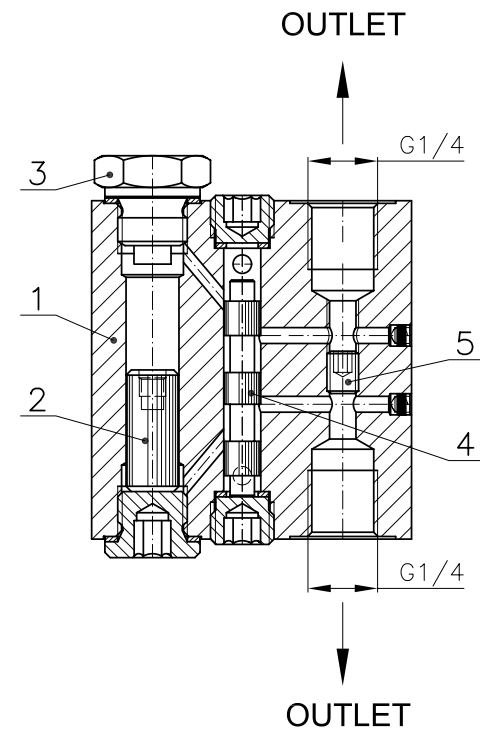
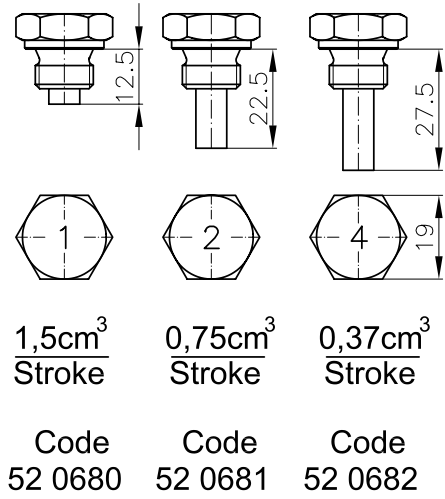

EXAMPLE OF ORDER

Type	Number of outlets	Size of metering screw			
		Piston 1	Piston 2	Piston 3	Piston 4
DLDF-P	8-8	2	4	1	2

DLDF-P 8-8 2412

Type	Code
DLDF-P 2-2	9 52 0676
DLDF-P 4-4	9 52 0677
DLDF-P 6-6	9 52 0678
DLDF-P 8-8	9 52 0679
DLDF-P 2-1	9 52 0690
DLDF-P 4-3	9 52 0691
DLDF-P 6-5	9 52 0692
DLDF-P 8-7	9 52 0693

Pos	Name
1	Distributor body
2	Metering piston
3	Metering screw
4	Servo piston
5	Blocking screw

Name	TWO-LINE DISTRIBUTOR	
Type	DLDF-P	
Code		