



OM SERIES MEDIUM CAPACITY (OVAL GEAR FLOWMETERS)

The FLOMEC® OM Medium Capacity Oval Gear Meters are great for medium flow ranges and have the ability to handle a wide range of fluid viscosities.

FEATURES / BENEFITS

- High accuracy and repeatability, direct volumetric reading
- Measures high and low viscosity liquids
- Quadrature pulse output option and bi-directional flow
- Optional Exd I/IB approval (ATEX, IECEx)
- No requirement for flow conditioning (straight pipe runs)
- Only two moving parts

PRODUCT CONFIGURATION

1 PRODUCT IDENTIFIER:

OM = Oval Gear Meter

2 METER SIZE:

- 015** = 1/2 inch (15 mm), 0.26-10.6 GPM (1-40 L/min)
025 = 1 inch (25 mm), 2.6-40 GPM (10-150 L/min)
040 = 1-1/2 inch (40 mm), 4-66 GPM (15-250 L/min)
050 = 2 inch (50 mm), 8-118 GPM (30-450 L/min) with SS Rotors
050 = 2 inch (50 mm), 8-130 GPM (30-500 L/min) with PPS Rotors

3 BODY MATERIAL:

- A** = Aluminum
M = Intermediate pressure aluminum meter (2000 PSI / 138 bar max.) (OM025 only)
S = 316L Stainless Steel
N = Intermediate Pressure 316L SS (OM015-OM025N = 1450 PSI / 100 bar) (OM040N-OM050N = 725 PSI / 50 bar)

4 ROTOR MATERIAL / BEARING TYPE:

- 00** = PPS (Not available for 300° F [150° C] meters) / No bearing
10 = Keishi cut PPS (for high viscosity liquids) (not available for 300° F [150° C] meters) / No bearing
51 = Stainless Steel / Carbon Ceramic
71 = Keishi cut Stainless Steel (For high viscosity liquids) / Carbon Ceramic

5 O-RING MATERIAL:

- 1** = FKM (Viton™) 5° F minimum (-15° C)
3 = PTFE encapsulated FKM (Viton™) 5° F minimum (-15° C)
4 = Buna-N (Nitrile) -40° F minimum (-40° C)

6 MAXIMUM TEMPERATURE LIMIT:

- 2** = 250° F (120° C) max.
-3 = 300° F (150° C) max. (Hall Effect) (Includes Stainless Steel terminal cover)
-5 = 250° F (120° C) max. (includes integral cooling fin)
-8 = 176° F (80° C) max. (meters with integral instruments) (OM008 with PPS rotors)

7 PROCESS CONNECTIONS:

- 0** = No fittings (Not available on 015 size)
1 = BSPP (G) female threaded (ISO 228)
2 = NPT female threaded
3 = Sanitary Fittings (1/2 inch larger than meter size)
4 = ANSI-150 RF Flanged
5 = ANSI-300 RF Flanged
6 = PN16 DIN Flanged

8 CABLE ENTRIES:

- 1** = M20 x 1.5 mm (M16 x 1.5 mm for R4 options)
2 = 1/2 inch NPT
6 = 3 x 16 mm drilled holes (for R7/F15/F18/F19/F31)

9 INTEGRAL OPTIONS:

- __** = Combination Reed Switch and Hall Effect Sensor
SS = Stainless Steel terminal cover
RS = Reed Switch only - to suit Intrinsically safe installations
E1 = Explosion proof Exd IIB T3...T6 (Aluminum & Stainless Steel meters) [IECEx & ATEX approved]
E2 = Explosion proof Exd I/IB T3...T6 (Stainless Steel meters only) [IECEx & ATEX mines approved]
FP = cFMus Approved, USA and Canada, Flameproof Class 1 Zone 1
QP = Quadrature pulse (2 NPN phased outputs) Recommended remote display: F115... (part # 1431135)
QPN = Quadrature pulse (2 NPN phased outputs) with Australian NMI & NZ approval for trade sale (1, 1.5, and 2 inch only)
Q1 = Combination of the E1 & QP Integral Options
Q1N = Explosion Proof Exd (IECEx & ATEX) with Quadrature pulse with Australian NMI & NZ approval for trade sale (1, 1.5, and 2 inch only)
R4 = RT40 backlit rate totaliser in Aluminum housing, requires Cable Entry option 1*#
R5 = RT14 backlit rate totalizer with all outputs (GRN Housing)*#
R6 = RT14 IECEx/ATEX Intrinsically Safe rate totaliser with 4-20mA and pulse outputs, in GRN housing*#
R7 = RT40 backlit rate totaliser in GRN housing*#
B11 = EB11 dual stage batch controller in GRN housing*#
E18 = E018 backlit rate/tot, pulse, 4-20mA, 10 point linearization, HART, aluminium body [IECEx & ATEX approved]*#
E19 = E018 backlit rate/tot, pulse, 4-20mA, 10 point linearization, HART, stainless steel body [IECEx & ATEX approved]*#
F15 = F115 bi-directional flow rate/totaliser, 4-20mA and pulse outputs, in a GRN housing
F18 = F018 backlit rate/tot, pulse, 4-20mA, 10 point linearization, HART*#
F19 = F018 backlit rate/tot, pulse, 4-20mA, 10 point linearization, HART, Intrinsically safe*#^[IECEx & ATEX approved]
F31 = Intrinsically safe F130 2 stage batch controller*#^[IECEx & ATEX approved]

10 DISPLAY CALIBRATION:

- __** = Displays in Litres (DEFAULT)
G = Displays in US Gallons

1 2 3 4 5 6 7 8 9 10
 --->>>> OM 025 A 51 2 -5 2 1 R4 G

SPECIFICATIONS

	OM015	OM025	OM040	OM050
Nominal Size:	1/2 in. (15 mm)	1 in. (25 mm)	1 1/2 in. (40 mm)	2 in. (50 mm)
*Flow Range:	0.26-10.6 GPM (1-40 L/min)	2.6-40 GPM (10-150 L/min)	4-66 GPM (15-250 L/min)	8-120 GPM (30-450 L/min) (SS) 8-130 GPM (30-500 L/min) (PPS)
Accuracy @3cp:	± 0.5% of reading (accuracy is ± 0.2% of reading with optional RT14 with non-linearity correction)			
Repeatability:	Typically ± 0.03% of reading			
Temperature Range:	-40° F to +300° F (-40° C to +150° C) refer to factory for lower temperature			
Pressure Rating (Threaded Meter):				
Aluminum	990 PSI (68 bar)	990 PSI (68 bar)	435 PSI (30 bar)	285 PSI (20 bar)
Intermediate Pressure Aluminum		2000 PSI (138 bar)		
316 Stainless Steel	990 PSI (68 bar)	990 PSI (68 bar)	435 PSI (30 bar)	550 PSI (38 bar)
Intermediate Pressure SS	1450 PSI (100 bar)	1450 PSI (100 bar)	725 PSI (50 bar)	725 PSI (50 bar)
Recommended Filtration	100 mesh (150 µm)			

DIMENSIONS

All dimensions are ± .079 (±2 mm)

Modular Fitting	A				
	OM015	OM025A	OM025S/N	OM040	OM050
A.N.S.I. 150 DIN16	7.4 in. (189 mm)	7.8 in. (198 mm)	9.3 in. (237 mm)	9.9 in. (252 mm)	10.9 in. (277 mm)
B.S.P N.P.T.	4.3 in. (110 mm)	5.4 in. (137 mm)	6.9 in. (176 mm)	7.4 in. (188 mm)	8.3 in. (212 mm)

Configuration	B						
	OM015A	OM015S/N	OM025A	OM025S/N	OM040A	OM040S/N	OM050
EB11 / RT14 GRN Housing	6.0 in. (154 mm)	5.8 in. (148 mm)	6.6 in. (168 mm)	6.5 in. (165 mm)	7.9 in. (203 mm)	7.6 in. (194 mm)	8.6 in. (218 mm)
RT40 Alloy Housing	6.2 in. (157 mm)	5.9 in. (151 mm)	6.7 in. (171 mm)	6.6 in. (168 mm)	8.1 in. (206 mm)	7.8 in. (197 mm)	8.7 in. (221 mm)
Cover	4.2 in. (106 mm)	3.9 in. (100 mm)	4.7 in. (123 mm)	4.6 in. (117 mm)	6.1 in. (155 mm)	5.7 in. (146 mm)	6.7 in. (170 mm)

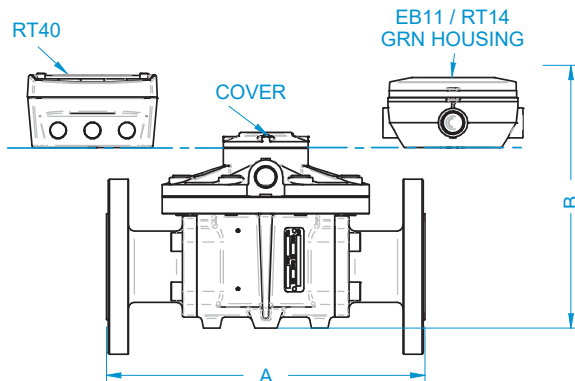

	OM015	OM025	OM040	OM050
Electrical:				
Output Pulse Resolution:	Pulses / gallon (Pulses / L) - Nominal			
Reed Switch	318 (84)	102 (27)	53 (14)	25 (6.5)
Hall Effect	636 (168)	405 (107)	212 (56)	99 (26)
QP - Quadrature Hall Option	636 (168)	204 (54)	106 (28)	49 (13)
Reed Switch Output	30V (dc) x 200mA max. [maximum thermal shock 18° F (10° C) / minute]			
Hall Effect Output (NPN)	3 wire open collector, 5-24V (dc) max., 20mA max.			
Optional Outputs	4-20mA, scaled pulse, quadrature pulse, flow alarms or two stage batch control			

*Maximum flow is to be reduced as viscosity increases, see flow de-rating guide. Max recommended pressure drop is 14.5 psi (1 bar).

APPROVALS

CE NEMA 4X IP66/67

FM APPROVED Class 1, Zone 1, AEx db 11B T4 Gb Ta=-40°C to +120°C
Ex db 11B T4 Gb Ta=-40°C to +120°C

STAINLESS STEEL MODELS ONLY

ATEX 1 M2 Ex db 1Mb OR ATEX 11 2 G Ex db 11B T6...T3 Gb

IECEx Ex db 1 Mb Ex db 11B T6.....T3 Gb

Refer to Specific Conditions for Process and Ambient Temperature

APPLICATIONS

- Oils
- Fuel
- Diesel
- Truck Metering
- Bunker C Fuel Oil
- Chemical Additive Injection
- Batching
- Molasses
- Clean Fluids
- Oil-Based Paints
- Industrial Fluids
- Chemical Feed Lines

OM040: Ø6.3 in. (160 mm)
OM050: Ø7.1 in. (180 mm)
OM015: Ø4.3 in. (110 mm)
OM025: Ø4.7 in. (120 mm)

