



Application

Solenoid valves for controlling pneumatic actuators in hazardous areas

The Type 3963 Solenoid Valve provides a high level of operating safety and short actuating times for controlling pneumatic actuators in hazardous areas. Intrinsically safe, low-power binary signals issued by automation equipment or fieldbus systems can be used for controlling purposes.

Different switching functions, flow rates and connection types allow the variable configuration of the solenoid valve to suit individual applications (Fig. 1 to Fig. 3).

General features

- SIL according to IEC 61508 (optional)
- Fail-safe action for use on control valves (optional)
- Corrosion-resistant enclosure with degree of protection IP 54 or IP 65 for use in humid or rough ambient conditions
- Version compatible with paint (on request)
- Service life of over 20 million switching cycles
- Ambient temperature range -20 to $+80$ °C or -45 to $+80$ °C
- Rail, wall or pipe mounting
- Mounting to linear actuators with NAMUR rib according to IEC 60534-6-1 or to rotary actuators with NAMUR interface according to VDI/VDE 3845

Special features of the pilot valve

- Electropneumatic binary converter with flapper/nozzle assembly
- Nominal signal 6/12/24 V DC or 115/230 V AC
- Type of protection according to table "Summary of explosion protection approvals" on page 25
- 6 to 27 mW or 0.04 to 0.46 VA power consumption (depending on nominal signal)
- Manual override using pushbutton or switch (optional)
- Pilot supply 1.4 to 6 bar



Fig. 1: 5/2-way solenoid valve · Actuated on one side · With spring return mechanism · K_{VS} 0.16 · G $\frac{1}{4}$ connection

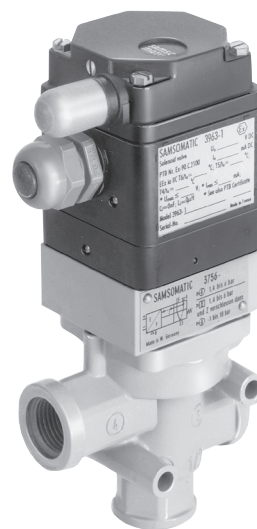

Fig. 2: 3/2-way solenoid valve · Actuated on one side · With spring return mechanism · K_{VS} 4.3 · G $\frac{1}{2}$ connection

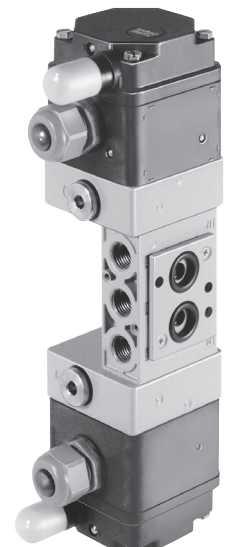

Fig. 3: 5/2-way solenoid valve · Actuated on both sides · With two detent positions · K_{VS} 1.4 · G $\frac{1}{4}$ connection, NAMUR

- Electrical connection using M20x1.5 cable gland to terminals or with connector
- Cable break protection (accessories)

Special features of the booster valve

- Diaphragm actuator with return spring or spool actuated either on one side or both sides
- 3/2-, 5/2-, 5/3 or 6/2-way function

- Exhaust air feedback (optional)
- K_{VS} coefficients 0.16 to 4.3
- Supply/exhaust air restrictions to adjust different closing and opening times in a ratio of 1:1.5 (optional) · ▶ AB 11
- G 1/4 or G 1/2 (1/4 NPT or 1/2 NPT) threaded connections
- NAMUR interface 1/4" or 1/2"

Table 1: Versions with threaded connection

Table 1.1: Solenoid valves for mounting on actuators for throttling or on/off service





			
 <p>Type 3963-XXX003240XXXXX Solenoid Valve</p> <ul style="list-style-type: none"> - 3/2-way function - K_{VS} 0.32 - Safety function (SIL/TÜV) - Mounting with connection block on Type 3277 Linear Actuator with Types 3730, 3766, 3767 and 378X Positioners 	 <p>Type 3963-XXX0022XXXXXXX Solenoid Valve</p> <ul style="list-style-type: none"> - 3/2-way function - K_{VS} 0.32 - G 1/4 or 1/4 NPT connection - Safety function (SIL/TÜV) - Mounting to linear actuators with NAMUR rib, e.g. Type 3271 	 <p>Type 3963-XXX0012XXXXXXX Solenoid Valve</p> <ul style="list-style-type: none"> - 3/2-way function - K_{VS} 0.32 - G 1/4 or 1/4 NPT connection - Safety function (SIL/TÜV) - Rail mounting, wall mounting or mounting to linear actuators (e.g. Type 3271 or Type 3277) using pipe fitting 	 <p>Type 3963-XXX1011XXXXXXX Solenoid Valve</p> <ul style="list-style-type: none"> - 5/2-way function - K_{VS} 0.16 - G 1/4 or 1/4 NPT connection - Rail or wall mounting
 <p>Type 3963-XXX013141XXXXX Solenoid Valve</p> <ul style="list-style-type: none"> - 3/2-way function - Adjustable exhaust air restrictor - K_{VS} 0.16 - Mounting with connection block on Type 3277 Linear Actuator with Types 3730, 3766, 3767 and 378X Positioners 		 <p>Type 3963-XXX0011XXXXXXX Solenoid Valve</p> <ul style="list-style-type: none"> - 3/2-way function - K_{VS} 0.16 - G 1/4 or 1/4 NPT connection - Rail mounting, wall mounting or mounting to linear actuators (e.g. Type 3271 or Type 3277) for on/off service using pipe fitting 	 <p>Type 3963-XXX8011XXXXXXX Solenoid Valve</p> <ul style="list-style-type: none"> - 6/2-way function - K_{VS} 0.16 - G 1/4 or 1/4 NPT connection - Rail or wall mounting
		 <p>Type 3963-XXX011XXXXXXX Solenoid Valve</p> <ul style="list-style-type: none"> - 3/2-way function - Adjustable exhaust air restrictor - K_{VS} 0.16 - G 1/4 or 1/4 NPT connection - Rail mounting, wall mounting or mounting to linear actuators (e.g. Type 3271 or Type 3277) for on/off service using pipe fitting 	

Table 1.2: Solenoid valves for mounting on actuators for throttling or on/off service

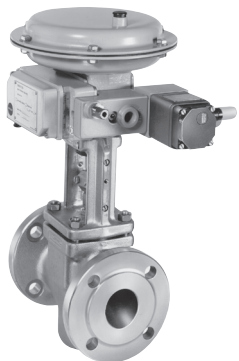

			
 <p>Type 3963-XXX0014XXXXXXX Solenoid Valve</p> <ul style="list-style-type: none"> - 3/2-way function - K_{VS} 4.3 - G 1/2 or 1/2 NPT connection - Safety function (SIL/TÜV) - Wall mounting or mounting to linear actuators (e.g. Type 3271 or Type 3277) using pipe fitting 	 <p>Type 3963-XXX1014XXXXXX0 Solenoid Valve</p> <ul style="list-style-type: none"> - 5/2-way function - K_{VS} 4.3 - G 1/2 or 1/2 NPT connection - Wall or pipe mounting 	 <p>Type 3963-XXX0013XXXXXXX Solenoid Valve</p> <ul style="list-style-type: none"> - 3/2-way function - Exhaust air feedback - K_{VS} 1.4 - G 1/4 or 1/4 NPT connection - Safety function (TÜV) - Wall mounting or mounting to linear actuators (e.g. Type 3271 or Type 3277) using pipe fitting 	 <p>Type 3963-XXX2013XXXXXXX Solenoid Valve</p> <ul style="list-style-type: none"> - 5/2-way function with two detent positions - K_{VS} 1.4 - G 1/4 or 1/4 NPT connection - Safety function (TÜV) - Wall or pipe mounting
	 <p>Type 3963-XXX8014XXXXXX0 Solenoid Valve</p> <ul style="list-style-type: none"> - 6/2-way function - K_{VS} 4.3 - G 1/2 or 1/2 NPT connection - Wall or pipe mounting 	 <p>Type 3963-XXX1013XXXXXXX0 Solenoid Valve</p> <ul style="list-style-type: none"> - 5/2-way function - K_{VS} 1.4 - G 1/4 or 1/4 NPT connection - Wall mounting or mounting to linear actuators (e.g. Type 3271 or Type 3277) using pipe fitting 	 <p>Type 3963-XXX3013XXXXXXX0 Solenoid Valve</p> <ul style="list-style-type: none"> - 5/3-way function with spring-centered mid-position (ports 2 and 4 closed) - K_{VS} 1.4 - G 1/4 or 1/4 NPT connection - Wall or pipe mounting
			 <p>Type 3963-XXX5013XXXXXXX0X Solenoid Valve</p> <ul style="list-style-type: none"> - 5/3-way function with spring-centered mid-position (ports 2 and 4 vented) - K_{VS} 1.4 - G 1/4 or 1/4 NPT connection - Safety function (TÜV) - Wall or pipe mounting

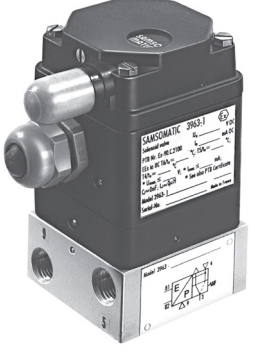
Table 2: Versions with NAMUR interface

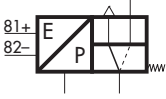
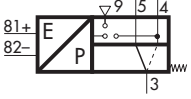
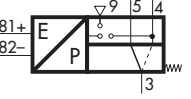
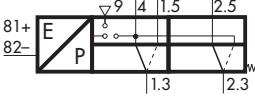
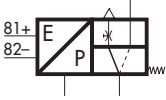
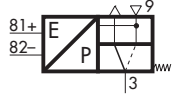
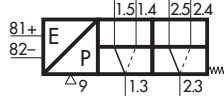
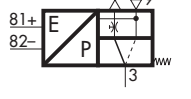
Table 2.1: Solenoid valves for mounting on actuators for throttling or on/off service



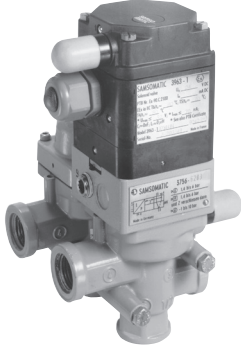

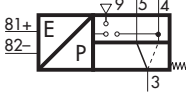
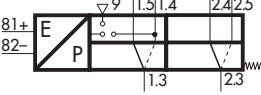
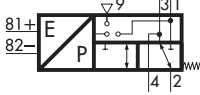
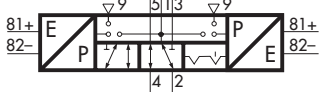
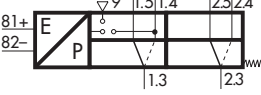
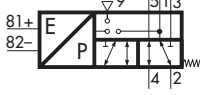
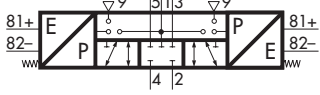
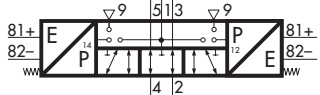





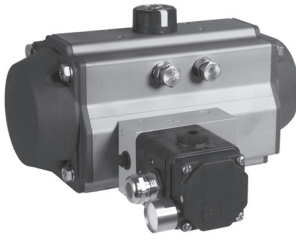

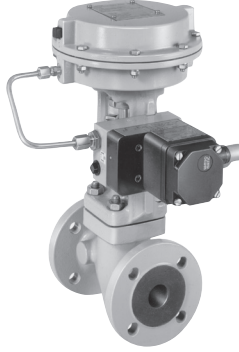
			
 <p>Type 3963-XXX0002XXXXXX Solenoid Valve</p> <ul style="list-style-type: none"> - 3/2-way function - Exhaust air feedback - K_{VS} 0.32 - G 1/4 or 1/4 NPT connection, NAMUR - Safety function (SIL/TÜV) - Mounting on rotary actuators with NAMUR interface (optionally with positioner) 	 <p>Type 3963-XXX8001XXXXXX Solenoid Valve</p> <ul style="list-style-type: none"> - 6/2-way function - K_{VS} 0.16 - G 1/4 or 1/4 NPT connection, NAMUR - Mounting on rotary actuators with NAMUR interface 	 <p>Type 3963-XXX0001XXXXXX Solenoid Valve</p> <ul style="list-style-type: none"> - 3/2-way function - Exhaust air feedback - K_{VS} 0.16 - G 1/4 or 1/4 NPT connection, NAMUR - Safety function (SIL/TÜV) - Mounting on rotary actuators for on/off service with NAMUR interface or with an adapter plate (item no. 1400-6751) on linear actuators with NAMUR rib (e.g. Type 3241-1) 	 <p>Type 3963-XXX0007XXXXXX Solenoid Valve</p> <ul style="list-style-type: none"> - 3/2-way function - Exhaust air feedback - K_{VS} 2.0 - G 1/4 or G 1/2/1/4 NPT or 1/2 NPT connection, NAMUR 1/4" - Safety function (SIL/TÜV) - Mounting on rotary actuators for on/off service with NAMUR interface 1/8" or 1/4" or mounting on linear actuators with NAMUR rib using an adapter plate (item no. 1400-6751)
 <p>Type 3963-XXX1001XXXXXX Solenoid Valve</p> <ul style="list-style-type: none"> - 5/2-way function - K_{VS} 0.16 - G 1/4 or 1/4 NPT connection, NAMUR - Mounting on rotary actuators for on/off service with NAMUR interface 	 <p>Type 3963-XXX0101XXXXXX Solenoid Valve</p> <ul style="list-style-type: none"> - 3/2-way function - Exhaust air feedback - Adjustable exhaust air restrictor - K_{VS} 0.16 - G 1/4 or 1/4 NPT connection, NAMUR - Mounting on rotary actuators for on/off service with NAMUR interface or with an adapter plate (item no. 1400-6751) on linear actuators with NAMUR rib (e.g. Type 3241-1) 		
 <p>Type 3963-XXX1201XXXXXX Solenoid Valve</p> <ul style="list-style-type: none"> - 5/2-way function - Two adjustable exhaust air restrictors - K_{VS} 0.16 - G 1/4 or 1/4 NPT connection, NAMUR - Mounting on rotary actuators for on/off service with NAMUR interface 		 <p>Type 3963-XXX0301XXXXXX Solenoid Valve</p> <ul style="list-style-type: none"> - 3/2-way function - Adjustable supply air/exhaust air restrictors - K_{VS} 0.16 - G 1/4 or 1/4 NPT connection, NAMUR - Mounting on rotary actuators with NAMUR interface or with an adapter plate (item no. 1400-6751) on linear actuators with NAMUR rib (e.g. Type 3241-1) 	

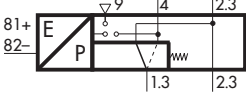
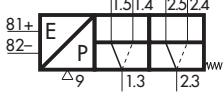
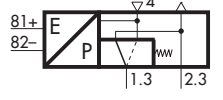
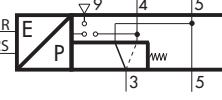
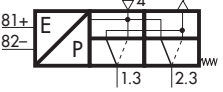
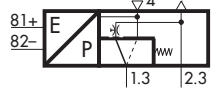
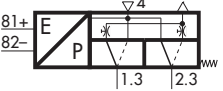
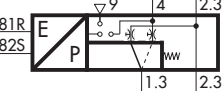
Table 2.2: Solenoid valves for mounting on actuators for throttling or on/off service

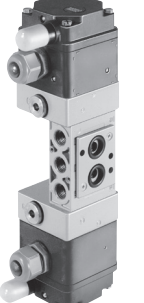
			
 <p>Type 3963-XXX0004XXXXXXXXX Solenoid Valve</p> <ul style="list-style-type: none"> - 3/2-way function - Exhaust air feedback - K_{VS} 4.3 - G 1/2/1/2 NPT connection or NAMUR 1/2" - Safety function (SIL/TÜV) - Mounting on rotary actuators for on/off service with NAMUR interface 3/8" or 1/2" 	 <p>Type 3963-XXX0003XXXXXXXXX Solenoid Valve</p> <ul style="list-style-type: none"> - 3/2-way function - Exhaust air feedback - K_{VS} 1.4 - G 1/4 or 1/4 NPT connection, NAMUR - Safety function (TÜV) - Mounting on rotary actuators with NAMUR interface or mounting on linear actuators with NAMUR rib using an adapter plate (item no. 1400-6751) 	 <p>Type 3963-XXX2003XXXXXXXXX Solenoid Valve</p> <ul style="list-style-type: none"> - 5/2-way function with two detent positions - K_{VS} 1.4 - G 1/4 or 1/4 NPT connection, NAMUR - Safety function (TÜV) - Mounting on rotary actuators with NAMUR interface 	 <p>Type 3963-XXX1006XXXXXXXXX Solenoid Valve</p> <ul style="list-style-type: none"> - 5/2-way function - K_{VS} 2.9 - G 1/2/1/2 NPT connection or NAMUR 1/2" - Mounting on rotary actuators with NAMUR interface 3/8" or 1/2"
 <p>Type 3963-XXX1003XXXXXXXXX Solenoid Valve</p> <ul style="list-style-type: none"> - 5/2-way function - K_{VS} 1.4 - G 1/4 or 1/4 NPT connection, NAMUR - Mounting on rotary actuators with NAMUR interface or mounting on linear actuators with NAMUR rib using an adapter plate (item no. 1400-6751) 	 <p>Type 3963-XXX3003XXXXXXXXX Solenoid Valve</p> <ul style="list-style-type: none"> - 5/3-way function with spring-centered mid-position (ports 2 and 4 closed) - K_{VS} 1.4 - G 1/4 or 1/4 NPT connection, NAMUR - Mounting on rotary actuators with NAMUR interface 		 <p>Type 3963-XXX5003XXXXXXXXX Solenoid Valve</p> <ul style="list-style-type: none"> - 5/3-way function with spring-centered mid-position (ports 2 and 4 vented) - K_{VS} 1.4 - G 1/4 or 1/4 NPT connection, NAMUR - Mounting on rotary actuators with NAMUR interface
 <p>Type 3963-XXX2006XXXXXXXXX Solenoid Valve</p> <ul style="list-style-type: none"> - 5/2-way function with two detent positions - K_{VS} 2.9 - G 1/2/1/2 NPT connection or NAMUR 1/2" - Mounting on rotary actuators with NAMUR interface 3/8" or 1/2" 	 <p>Type 3963-XXX5003XXXXXXXXX Solenoid Valve</p> <ul style="list-style-type: none"> - 5/3-way function with spring-centered mid-position (ports 2 and 4 vented) - K_{VS} 1.4 - G 1/4 or 1/4 NPT connection, NAMUR - Mounting on rotary actuators with NAMUR interface 	 <p>Type 3963-XXX2006XXXXXXXXX Solenoid Valve</p> <ul style="list-style-type: none"> - 5/2-way function with two detent positions - K_{VS} 2.9 - G 1/2/1/2 NPT connection or NAMUR 1/2" - Mounting on rotary actuators with NAMUR interface 3/8" or 1/2" 	 <p>Type 3963-XXX2006XXXXXXXXX Solenoid Valve</p> <ul style="list-style-type: none"> - 5/2-way function with two detent positions - K_{VS} 2.9 - G 1/2/1/2 NPT connection or NAMUR 1/2" - Mounting on rotary actuators with NAMUR interface 3/8" or 1/2"

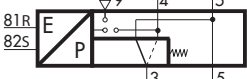
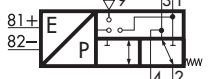
Design and principle of operation

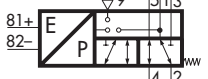
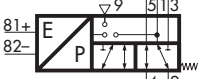
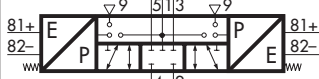
Solenoid valves actuated on one side

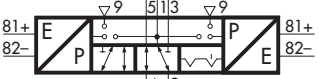
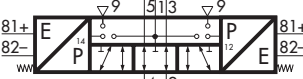
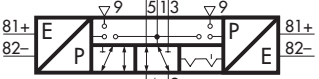
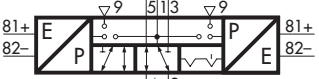
The solenoid valves consist of an electropneumatic binary converter (A) with manual override (B, optional) and a booster valve (C) actuated on one side with return spring (Fig. 4).

The air supply for the electropneumatic binary converter (A) is routed internally through the booster valve (C) (delivered state). The solenoid valve can be converted to accept an external pilot supply at port 9 by turning a gasket.

The pressure reducer (5) reduces the pilot pressure to 1.4 bar. In the idle position, the flapper (2) is lifted off the outlet nozzle (1) by the spring (3). As a result, a pressure lower than the deactivation pressure of the booster valve (C) builds up in the pressure divider, which consists of the restrictor (6) and outlet nozzle (1).

When the solenoid coil (4) is energized by an electric binary signal, the outlet nozzle (1) is closed by the flapper (2) against the force of the spring (3). This causes the pressure in the pressure divider to rise above the activation pressure of the booster valve (C), switching it to the operating position.

After the solenoid coil is de-energized, the booster valve (C) is switched to the neutral position again by a return spring.

Solenoid valves actuated on both sides

The solenoid valves consist of two electropneumatic binary converters (A) with manual override (B, optional) and a booster valve (C) actuated on both sides with two detent positions or spring-centered mid-position.

The air supply for the electropneumatic binary converters (A) is routed internally through the booster valve (C) (delivered state). The solenoid valve can be converted to accept an external pilot supply at port 9 by turning two gaskets.

The pressure reducer (5) reduces the pilot pressure to 1.4 bar. In the idle position, the flapper (2) is lifted off the outlet nozzle (1) by the spring (3). As a result, a pressure lower than the deactivation pressure of the booster valve (C) builds up in the pressure divider, which consists of the restrictor (6) and outlet nozzle (1).

When the solenoid coil (4) is energized by an electric binary signal, the outlet nozzle (1) is closed by the flapper (2) against the force of the spring (3). This causes the pressure in the pressure divider to rise above the activation pressure of the booster valve (C), switching it to the operating position.

After the solenoid coil is de-energized, the operating position of the detented booster valve (C) is kept until the opposing signal is received. The spring-centered booster valve (C) is switched to the mid-position by a return spring after the solenoid coil is de-energized.

A simultaneous control of the electropneumatic binary converter (A) must be ruled out on the electric control level.

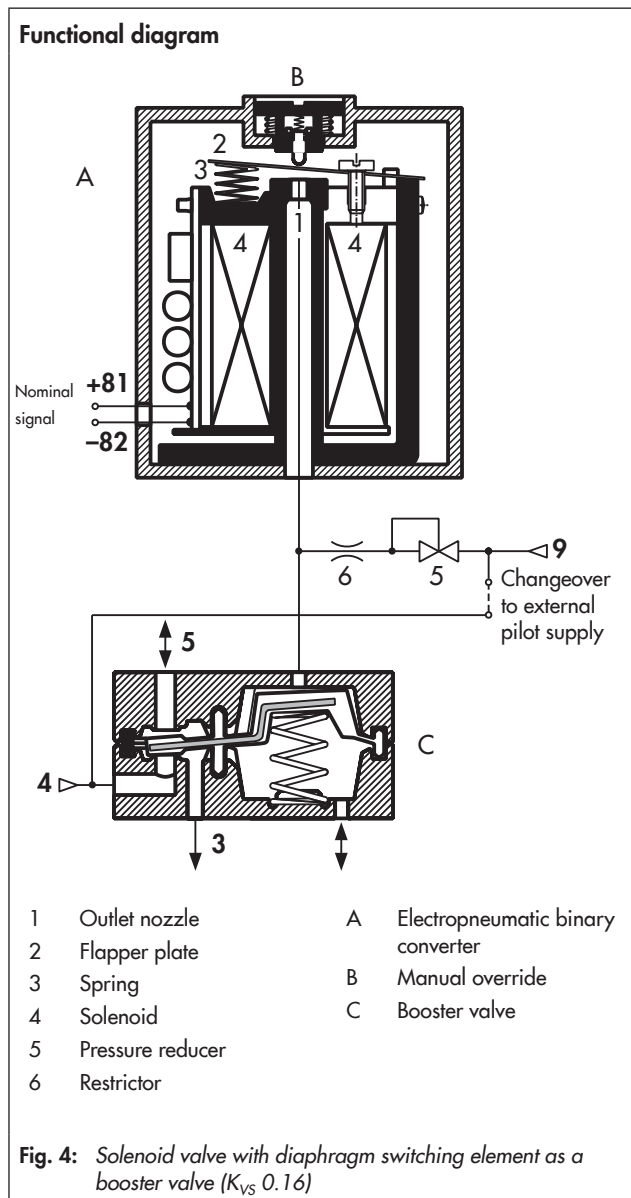

Technical data

General data		
Design		Solenoid with flapper/nozzle assembly and booster valve
Degree of protection		IP 54 with filter
		IP 65 with filter check valve
Material	Enclosure	Polyamide PA 6-3-T-GF35, black
	Connecting plate	AlMg, powder coated, gray beige RAL 1019 or Ematal coating (depending on the version: see article code)
		1.4404 (see 'Versions and ordering data' for special versions)
		Polyamide PA 6-3-T-GF35, black
	Screws	1.4571
	Springs	1.4310
	Seals	Silicone rubber, Perbunan
	Diaphragms	Chloroprene rubber 57 Cr 868 (-20 to +80 °C)
Silicone rubber (-45 to +80 °C)		
Supply air	Medium	Instrument air free from corrosive substances or nitrogen
	Pressure	1.4 to 6 bar/2.7 to 6 bar ¹⁾
Air consumption		≤80 l/h at 1.4 bar pilot supply in neutral position
		≤10 l/h at 1.4 bar pilot supply in operating position
Switching time		≤65 ms
Service life		≥2 x 10 ⁷ switching cycles (at -20 to +80 °C)
		≥2 x 10 ⁶ switching cycles (at -45 to +80 °C)
Ambient temperature		See 'Electric data'
Mounting orientation		Any desired position (► EB 3963)

¹⁾ Only in the version with K_{VS} 2.0 and 4.3 with attachment according to NAMUR interface

Electric data							
Type 3963		-X1	-X2	-X3	-06	-05	
Nominal signal	U_N	6 V DC Max. 27 V ¹⁾	12 V DC Max. 25 V ¹⁾	24 V DC Max. 32 V ¹⁾	115 V AC Max. 130 V ¹⁾	230 V AC Max. 255 V ¹⁾	
	f_N				48 to 62 Hz		
Switching point	ON	$U_{+80^\circ\text{C}}$	≥ 4.8 V	≥ 9.6 V	≥ 18 V	82 to 130 V	183 to 255 V
		$I_{+20^\circ\text{C}}$	≥ 1.41 mA	≥ 1.52 mA	≥ 1.57 mA	≥ 2.2 mA	≥ 2.6 mA
		$P_{+20^\circ\text{C}}$	≥ 5.47 mW	≥ 13.05 mW	≥ 26.71 mW	≥ 0.17 VA	≥ 0.46 VA
	OFF	$U_{-25^\circ\text{C}}$	≤ 1.0 V	≤ 2.4 V	≤ 4.7 V	≤ 18 V	≤ 36 V
Impedance	$R_{+20^\circ\text{C}}$	2.6 k Ω	5.5 k Ω	10.7 k Ω	Approx. 40 k Ω	Approx. 80 k Ω	
Effect of temperature		0.4 %/ $^\circ\text{C}$	0.2 %/ $^\circ\text{C}$	0.1 %/ $^\circ\text{C}$	0.05 %/ $^\circ\text{C}$	0.03 %/ $^\circ\text{C}$	

Type of protection Ex ia IIC²⁾ for use in hazardous areas (Zone 1)

Type 3963		-11	-12	-13		
Maximum values when connected to a certified intrinsically safe circuit						
Output voltage ⁴⁾	U_i	25 V · 27 V · 28 V · 30 V · 32 V				
Output current ⁴⁾	I_i	150 mA · 125 mA · 115 mA · 100 mA · 85 mA				
Power dissipation	P_i	250 mW	No restrictions			
Outer capacitance	C_i	≈ 0				
Outer inductance	L_i	≈ 0				
Ambient temperature in temperature class	T6	-45 to +60 $^\circ\text{C}$				
	T5	-45 to +70 $^\circ\text{C}$				
	T4	-45 to +80 $^\circ\text{C}$				

Type of protection Ex nA II³⁾ for use in hazardous areas (Zone 2)

Type 3963		-81	-82	-83		
Ambient temperature in temperature class	T6	-45 to +60 $^\circ\text{C}$				
	T5	-45 to +70 $^\circ\text{C}$				
	T4	-45 to +80 $^\circ\text{C}$				

1) Maximum permissible value at 100 % duty cycle. The maximum permissible value U_i applies to explosion-protected versions.

2) II 2G Ex ia IIC T6 according to EC type examination certificate PTB 01 ATEX 2085

3) II 3G Ex nA II T6 according to statement of conformity PTB 01 ATEX 2086 X

4) Pairs of values U_i/I_i apply to 6, 12, 24 V DC nominal signals.

Solenoid valves actuated on one side, K_{VS} 0.16 or K_{VS} 0.32				
Switching function	3/2-way function	3/2-way function	5/2-way function	6/2-way function
K_{VS} ¹⁾	0.16	0.32	0.16	0.16
Safety-instrumented function	SIL ³⁾ , TÜV ⁴⁾	SIL ³⁾ , TÜV ⁴⁾	SIL ³⁾ , TÜV ⁴⁾	-
Design	Diaphragm switching element, soft seated, with return spring			
Operating medium	Instrument air free from corrosive substances ⁵⁾ , air containing oil or non-corrosive gases ⁶⁾			
Operating pressure	1.4 to 6 bar			
Output signal	Operating pressure			
Ambient temperature ²⁾	-45 to +80 $^\circ\text{C}$			
Port	G 1/4 or 1/4 NPT			
Approx. weight	570 g (standard version)			

1) The air flow rate when $p_1 = 2.4$ bar and $p_2 = 1.0$ bar is calculated using the following formula: $Q = K_{VS} \times 36.22$ in m^3/h .

2) The permissible ambient temperature of the solenoid valve depends on the permissible ambient temperature of the components, type of protection and temperature class.

3) SIL according to IEC 61508

4) Emergency release or locking of compressed air supply

5) With internal pilot supply

6) With external pilot supply

Solenoid valve, actuated on one side, K_{VS} 4.3, with threaded connections				
Switching function	3/2-way function	3/2-way function	5/2-way function ⁸⁾	6/2-way function ⁸⁾
K_{VS} ¹⁾ (direction of flow)	1.9 (4→3), 1.5 (3→4) 4.3 (3→5), 4.7 (5→3)	1.9 (4→3), 1.5 (3→4) 4.3 (3→5), 4.7 (5→3)	1.9 (4→3), 1.5 (3→4) 4.3 (3→5), 4.7 (5→3)	1.9 (4→3), 1.5 (3→4) 4.3 (3→5), 4.7 (5→3)
Ambient temperature ²⁾	-20 to +80 °C	-45 to +80 °C	-20 to +80 °C	-20 to +80 °C
Safety-instrumented function	SIL ³⁾ , TÜV ⁴⁾	SIL ³⁾ , TÜV ⁴⁾	-	-
Design	Poppet valve with diaphragm actuator, soft seated, with return spring			
Material	Enclosure	Aluminum, powder coated, gray beige RAL 1019 1.4404 (see 'Versions and ordering data' for special versions)		
	Diaphragm	Chloroprene rubber	Silicone rubber	Chloroprene rubber
	Seals	Chloroprene rubber	Silicone rubber	Chloroprene rubber
	Screws	1.4571		
Control	Controlled on one side with a pilot valve, K_{VS} 0.16			
Operating medium	Instrument air free from corrosive substances or nitrogen ⁵⁾ Instrument air free from corrosive substances, air containing oil or non-corrosive gases ⁶⁾			
Max. operating pressure (direction of flow)	1.4 to 6 bar ⁵⁾ or 10 bar ⁶⁾ (4→3, 3→5) 2 bar (as required)	1.4 to 6 bar ⁵⁾ or 10 bar ⁶⁾ (4→3, 3→5) 2 bar (as required)	1.4 to 6 bar ⁵⁾ or 10 bar ⁶⁾ (as required) 2 bar (as required)	1.4 to 6 bar ⁵⁾ or 10 bar ⁶⁾ (as required) 2 bar (as required)
Switching cycles (operating pressure)	≥10 ⁷ (6 bar) ≥10 ⁶ (10 bar)	≥10 ⁶ (6 bar) ≥10 ⁵ (10 bar)	≥10 ⁷ (6 bar) ≥10 ⁶ (10 bar)	≥10 ⁷ (6 bar) ≥10 ⁶ (10 bar)
Port	G ½ or ½ NPT			
Approx. weight	585 g (standard version)		1100 g (standard version)	

Solenoid valve, actuated on one side, K_{VS} 2.0 or 4.3, with NAMUR interface				
Switching function	3/2-way function with exhaust air feedback			
K_{VS} ¹⁾ (direction of flow)	1.1 (4→3) 2.0 (3→5)	1.1 (4→3) 2.0 (3→5)	1.9 (4→3) 4.3 (3→5)	1.9 (4→3) 4.3 (3→5)
Ambient temperature ²⁾	-20 to +80 °C	-45 to +80 °C	-20 to +80 °C	-45 to +80 °C
Safety-instrumented function	SIL ³⁾ , TÜV ⁴⁾	SIL ³⁾ , TÜV ⁴⁾	SIL ³⁾ , TÜV ⁴⁾	SIL ³⁾ , TÜV ⁴⁾
Design	Poppet valve with diaphragm actuator, soft seated, with return spring			
Material	Enclosure	Aluminum, powder coated, gray beige RAL 1019 or Ematal coating (depending on the version: see article code) 1.4404 (see 'Versions and ordering data' for special versions)		
	Diaphragm	Chloroprene rubber	Silicone rubber	Silicone rubber
	Seals	Chloroprene rubber	Silicone rubber	Silicone rubber
	Screws	1.4571		
Control	Controlled on one side with a pilot valve, K_{VS} 0.16			
Operating medium	Instrument air free from corrosive substances or nitrogen ⁵⁾ Instrument air free from corrosive substances, air containing oil or non-corrosive gases ⁶⁾			
Max. operating pressure	2.7 to 6 bar ⁵⁾ or 10 bar ⁶⁾			
Switching cycles (operating pressure)	≥10 ⁷ (6 bar) ≥10 ⁶ (10 bar)	≥10 ⁶ (6 bar) ≥10 ⁵ (10 bar)	≥10 ⁷ (6 bar) ≥10 ⁶ (10 bar)	≥10 ⁷ (6 bar) ≥10 ⁵ (10 bar)
Port	Supply air	G ¼ or ¼ NPT, NAMUR interface ¼" ⁷⁾ , G ¾		G ½ or ½ NPT, NAMUR interface ½" ⁷⁾
	Exhaust air	G ½ or ½ NPT, NAMUR interface ½" ⁷⁾ , G ¾		G ½ or ½ NPT, NAMUR interface ½" ⁷⁾
Approx. weight	1380 g (standard version)		1500 g (standard version)	

1) The air flow rate when $p_1 = 2.4$ bar and $p_2 = 1.0$ bar is calculated using the following formula: $Q = K_{VS} \times 36.22$ in m³/h.

2) The permissible ambient temperature of the solenoid valve depends on the permissible ambient temperature of the components, type of protection and temperature class.

3) SIL according to IEC 61508

4) Emergency release or locking of compressed air supply

5) With internal pilot supply

6) With external pilot supply

7) NAMUR interface according to VDI/VDE 3845

8) Connecting hose between booster valves made of polyamide, see Fig. 12 and Fig. 13

Solenoid valves actuated on one side, K_{VS} 1.4 or K_{VS} 2.9		
Switching function	3/2-way function with exhaust air feedback	
	5/2-way function	
K_{VS} ¹⁾	1.4 or 2.9	
Safety-instrumented function	TÜV ²⁾ (with K_{VS} 1.4)	–
Design	Spool, metal-to-metal seat, zero overlap, with return spring	
Material	Enclosure	Aluminum, powder coated, gray beige RAL 1019 1.4404 (see 'Versions and ordering data' for special versions)
	Seals	Silicone
	Filter	Polyethylene
	Screws	1.4571
Control	Controlled on one side with a pilot valve, K_{VS} 0.01 (with 1.4) or K_{VS} 0.16 (with 2.9)	
Operating medium	Instrument air free from corrosive substances or nitrogen ³⁾ Instrument air free from corrosive substances, air containing oil or non-corrosive gases ⁴⁾	
Max. operating pressure	1.4 to 6 bar ³⁾ or 10 bar ⁴⁾	
Ambient temperature ⁵⁾	–45 to +80 °C	
Switching cycles	$\geq 2 \times 10^7$	
Port	K_{VS} 1.4	G 1/4 or 1/4 NPT, NAMUR interface ⁶⁾
	K_{VS} 2.9	G 1/2 or 1/2 NPT, NAMUR interface ⁶⁾
Approx. weight	K_{VS} 1.4	485 g (standard version)
	K_{VS} 2.9	1760 g (standard version)

Solenoid valves actuated on both sides, K_{VS} 1.4 or K_{VS} 2.9			
Switching function	5/2-way function with two detent positions	5/3-way function with spring-centered mid-position (ports 2 and 4 closed)	5/3-way function with spring-centered mid-position (ports 2 and 4 vented)
K_{VS} ¹⁾	1.4 or 2.9	1.4 (2.9 on request)	1.4 (2.9 on request)
Safety-instrumented function	TÜV ²⁾ (with K_{VS} 1.4)	–	TÜV ²⁾ (with K_{VS} 1.4)
Design	Spool, metal-to-metal seat, zero overlap		
Material	Enclosure	Aluminum, powder coated, gray beige RAL 1019 1.4404 (see 'Versions and ordering data' for special versions)	
	Seals	Silicone	
	Filter	Polyethylene	
	Screws	1.4571	
Control	Controlled on both sides with two pilot valves, K_{VS} 0.01 (with 1.4) or K_{VS} 0.16 (with 2.9)		
Operating medium	Instrument air free from corrosive substances or nitrogen ³⁾ Instrument air free from corrosive substances, air containing oil or non-corrosive gases ⁴⁾		
Max. operating pressure	1.4 to 6 bar ³⁾ or 10 bar ⁴⁾		
Ambient temperature ⁵⁾	–45 to +80 °C		
Switching cycles	$\geq 2 \times 10^7$		
Port	K_{VS} 1.4	G 1/4 or 1/4 NPT, NAMUR interface ⁶⁾	
	K_{VS} 2.9	G 1/2 or 1/2 NPT, NAMUR interface ⁶⁾	
Approx. weight	K_{VS} 1.4	685 g (standard version)	
	K_{VS} 2.9	2180 g (standard version)	

¹⁾ The air flow rate when $p_1 = 2.4$ bar and $p_2 = 1.0$ bar is calculated using the following formula: $Q = K_{VS} \times 36.22$ in m³/h.

²⁾ Emergency release or locking of compressed air supply

³⁾ With internal pilot supply

⁴⁾ With external pilot supply

⁵⁾ The permissible ambient temperature of the solenoid valve depends on the permissible ambient temperature of the components, type of protection and temperature class.

⁶⁾ NAMUR interface according to VDI/VDE 3845

Dimensions

All dimensions in mm

Dimensions of devices without threaded connections

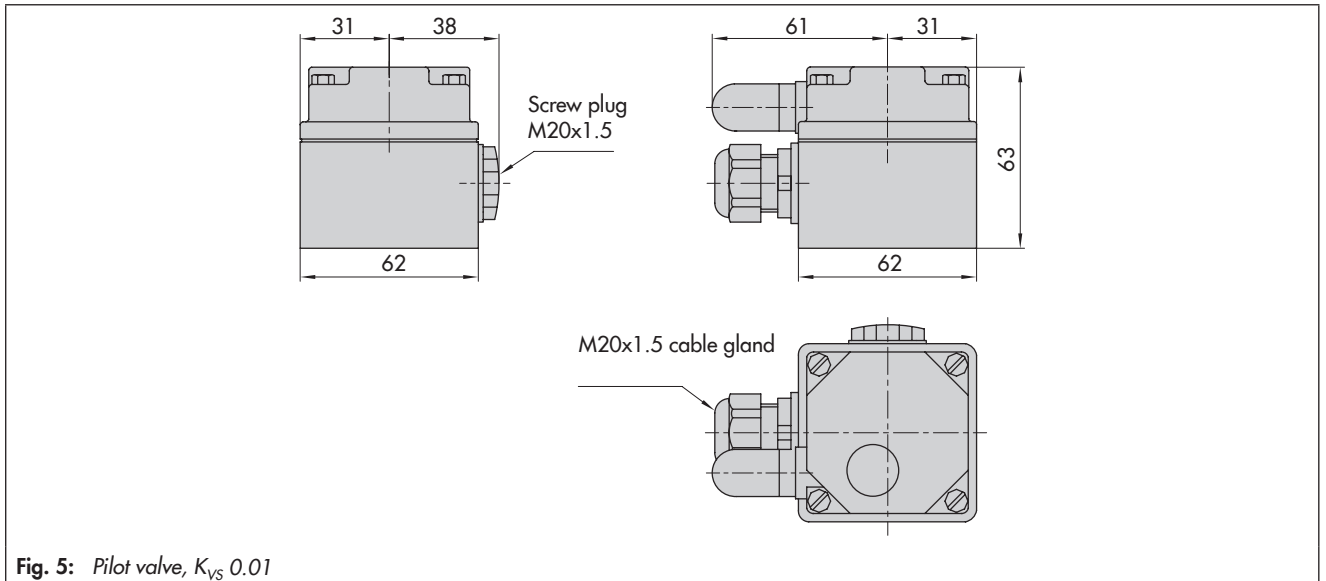

Fig. 5: Pilot valve, $K_{VS} 0.01$

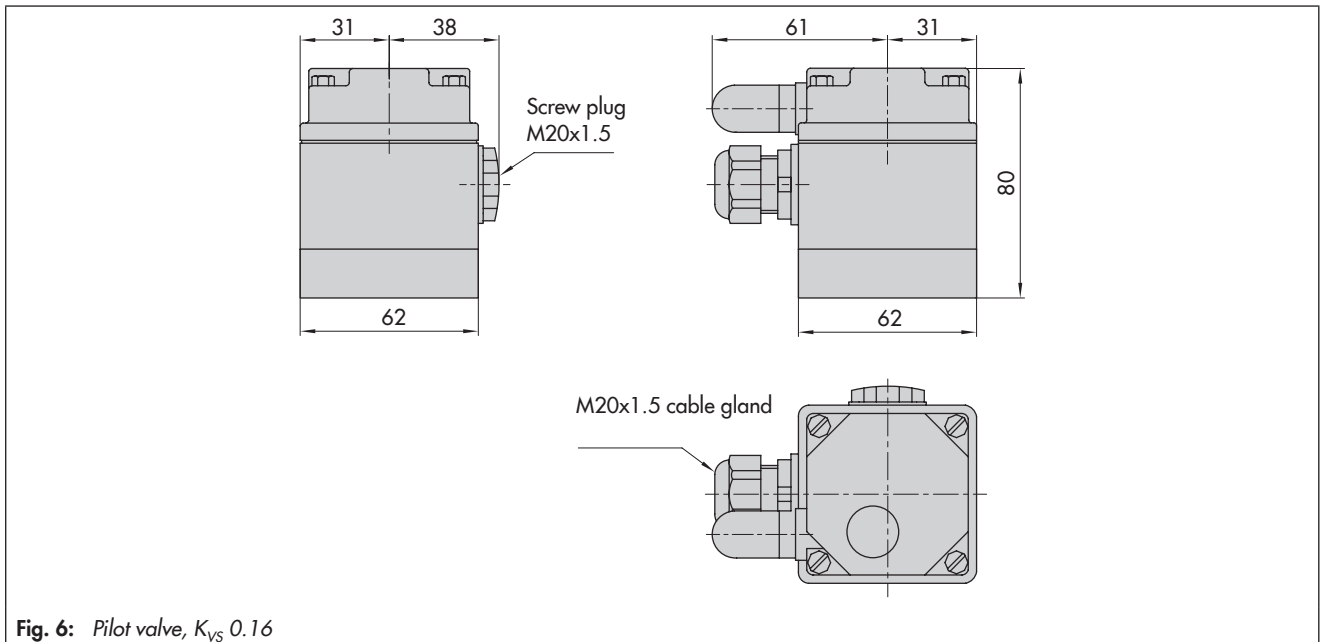

Fig. 6: Pilot valve, $K_{VS} 0.16$

Dimensions of devices with threaded connections

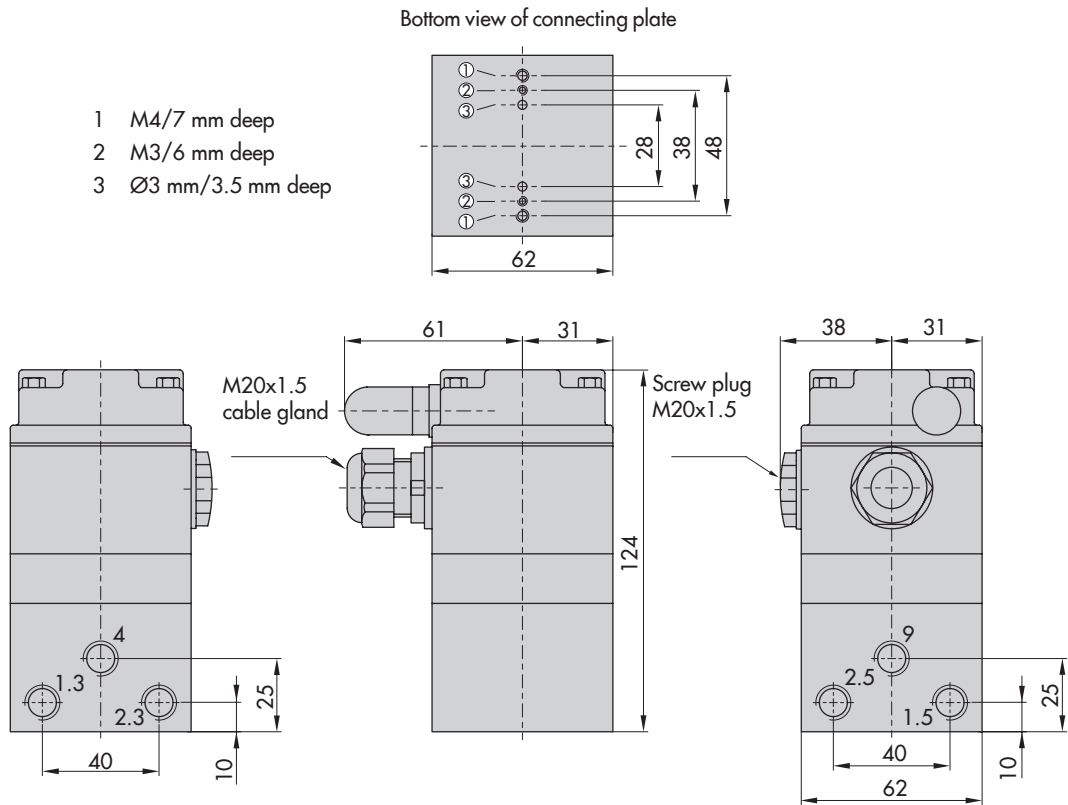

Fig. 7: 5/2-way solenoid valve, actuated on one side, K_{VS} 0.16

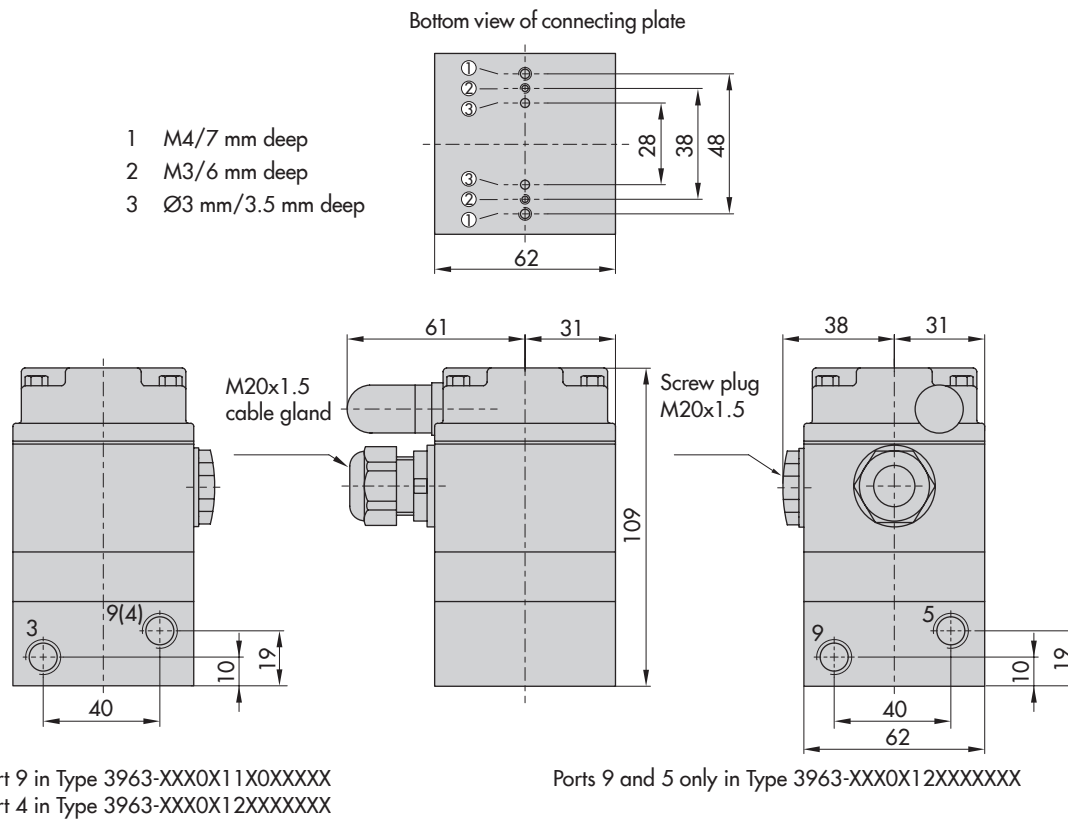
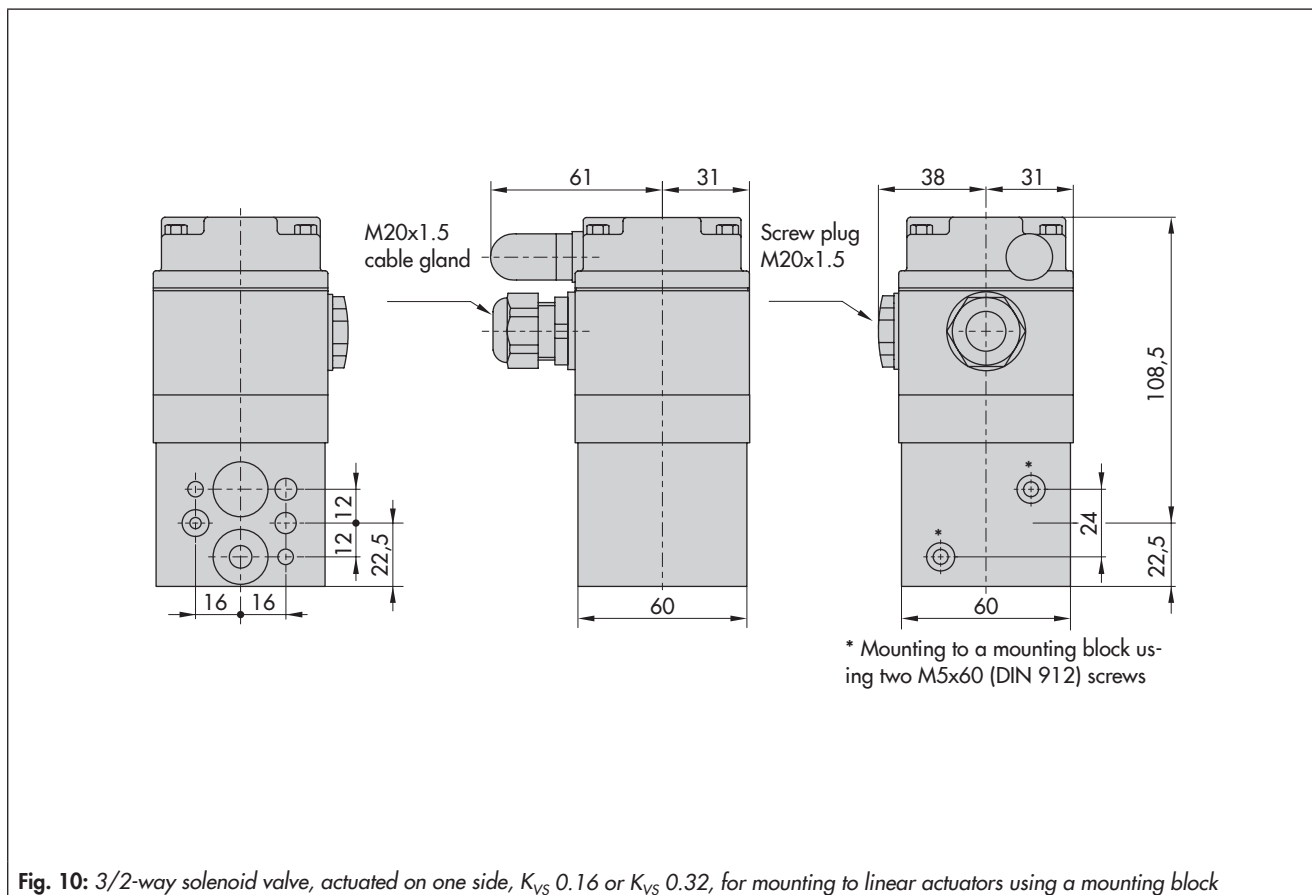
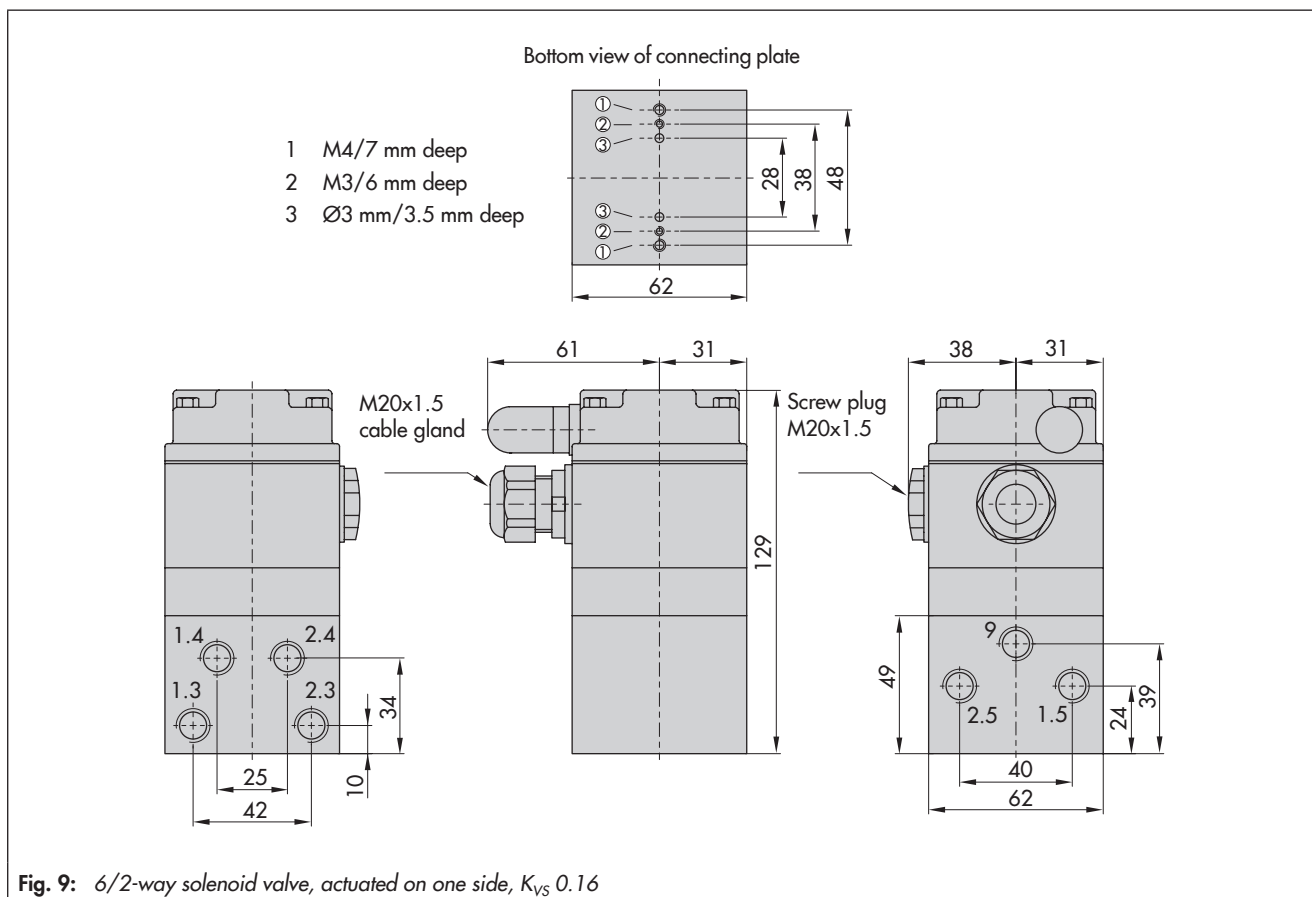

Fig. 8: 3/2-way solenoid valve, actuated on one side, K_{VS} 0.16 or K_{VS} 0.32



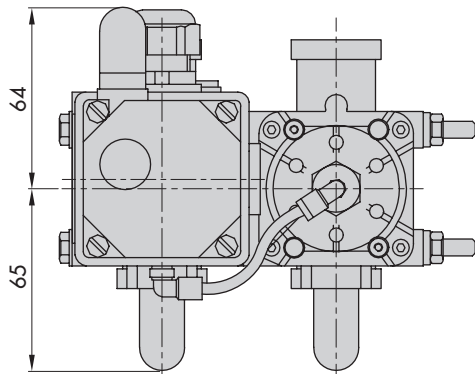
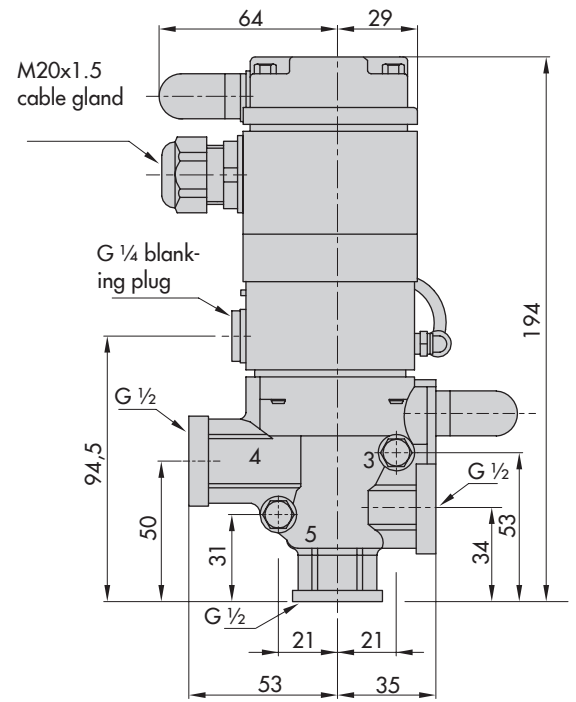
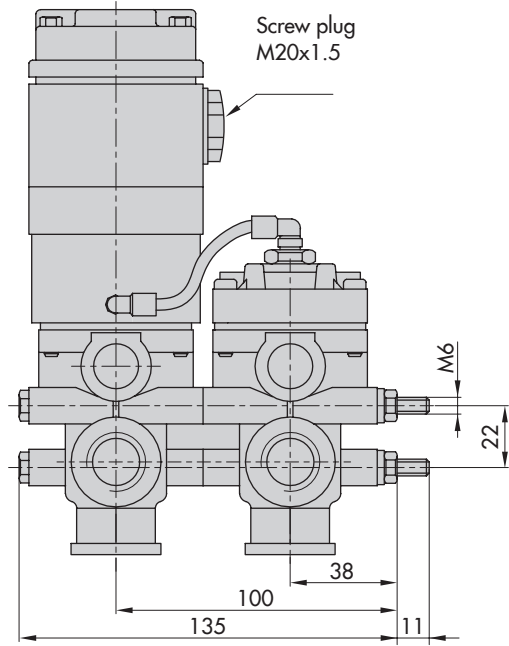
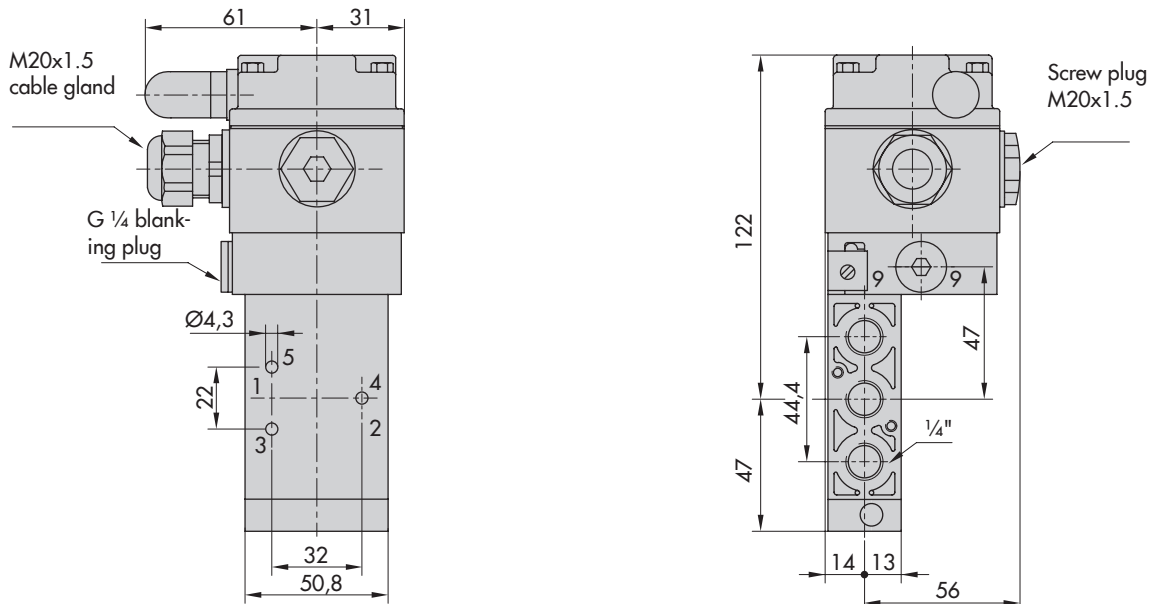

Fig. 13: 6/2-way solenoid valve, actuated on one side, K_{VS} 4.3



Port 5 is sealed when the 3/2-way function is used

Fig. 14: 3/2 or 5/2-way solenoid valve, actuated on one side, K_{VS} 1.4

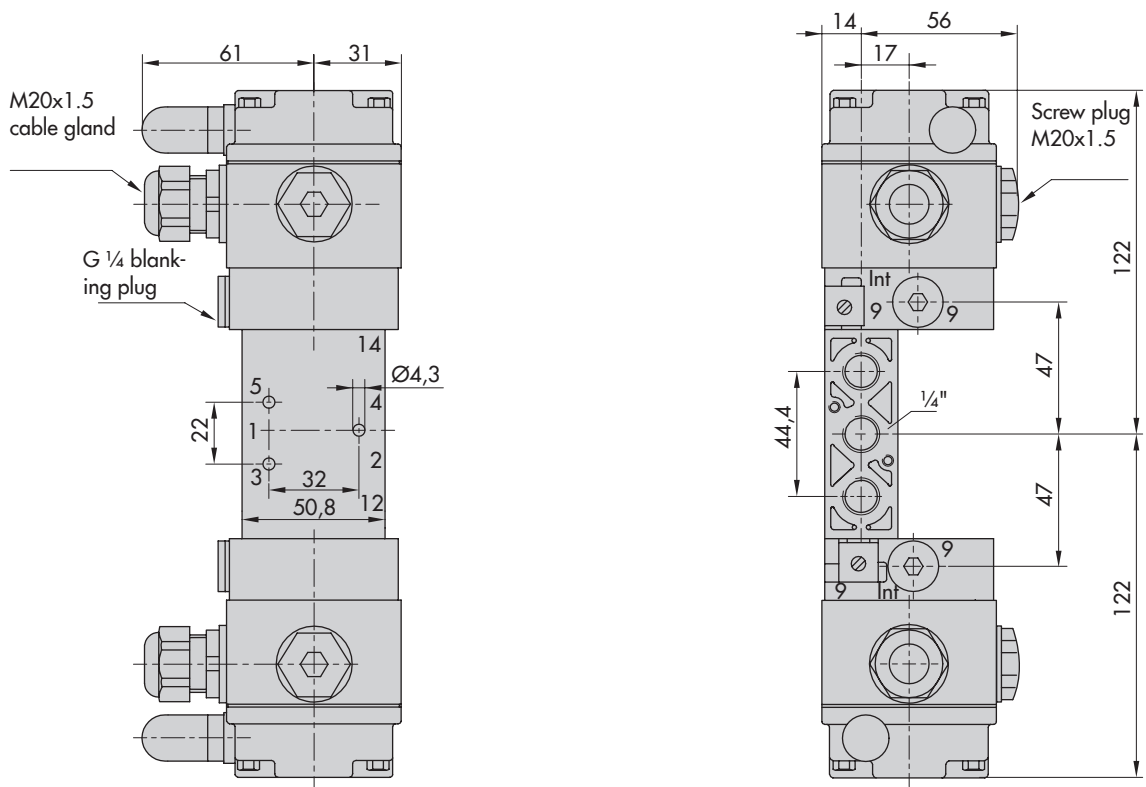
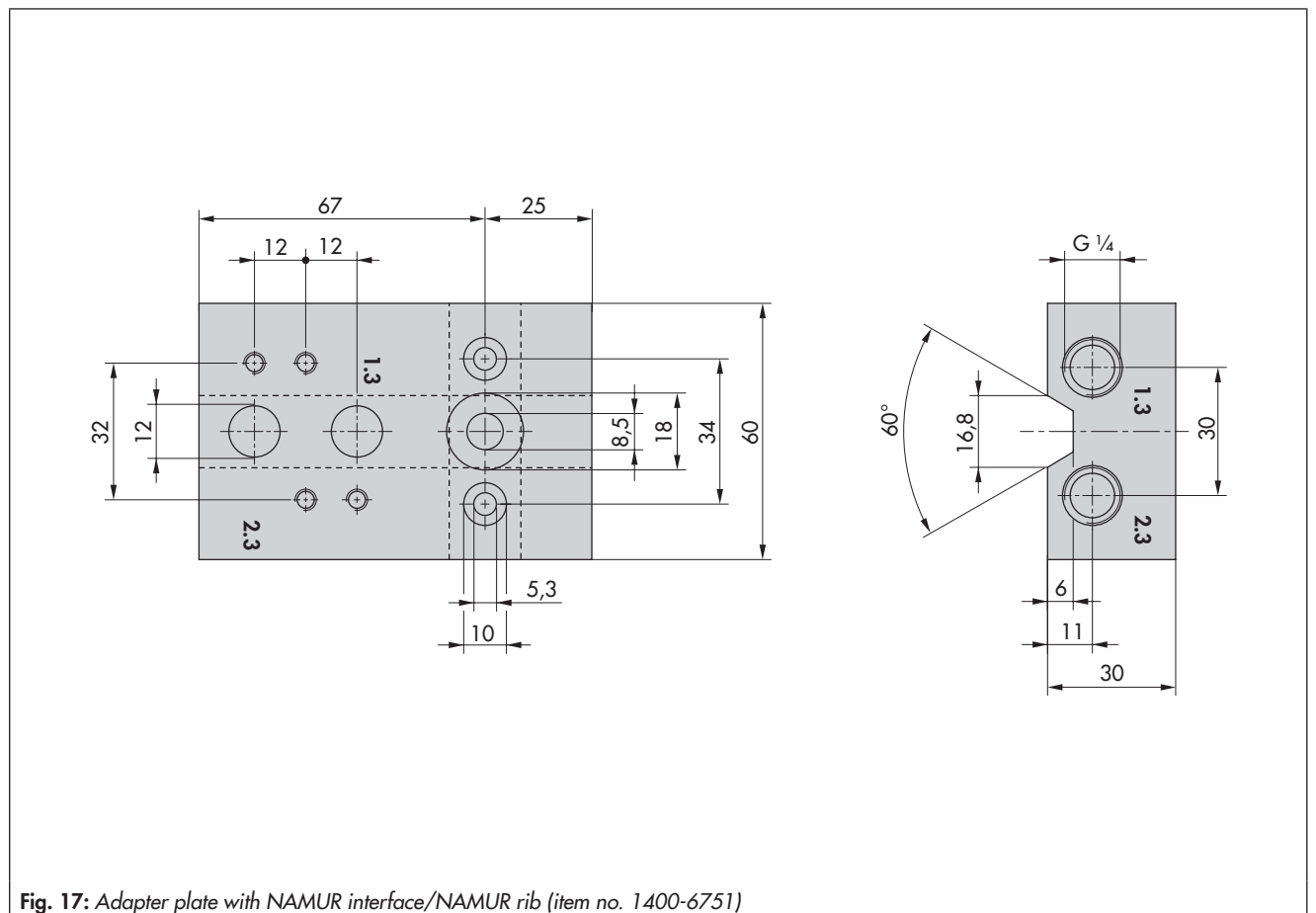
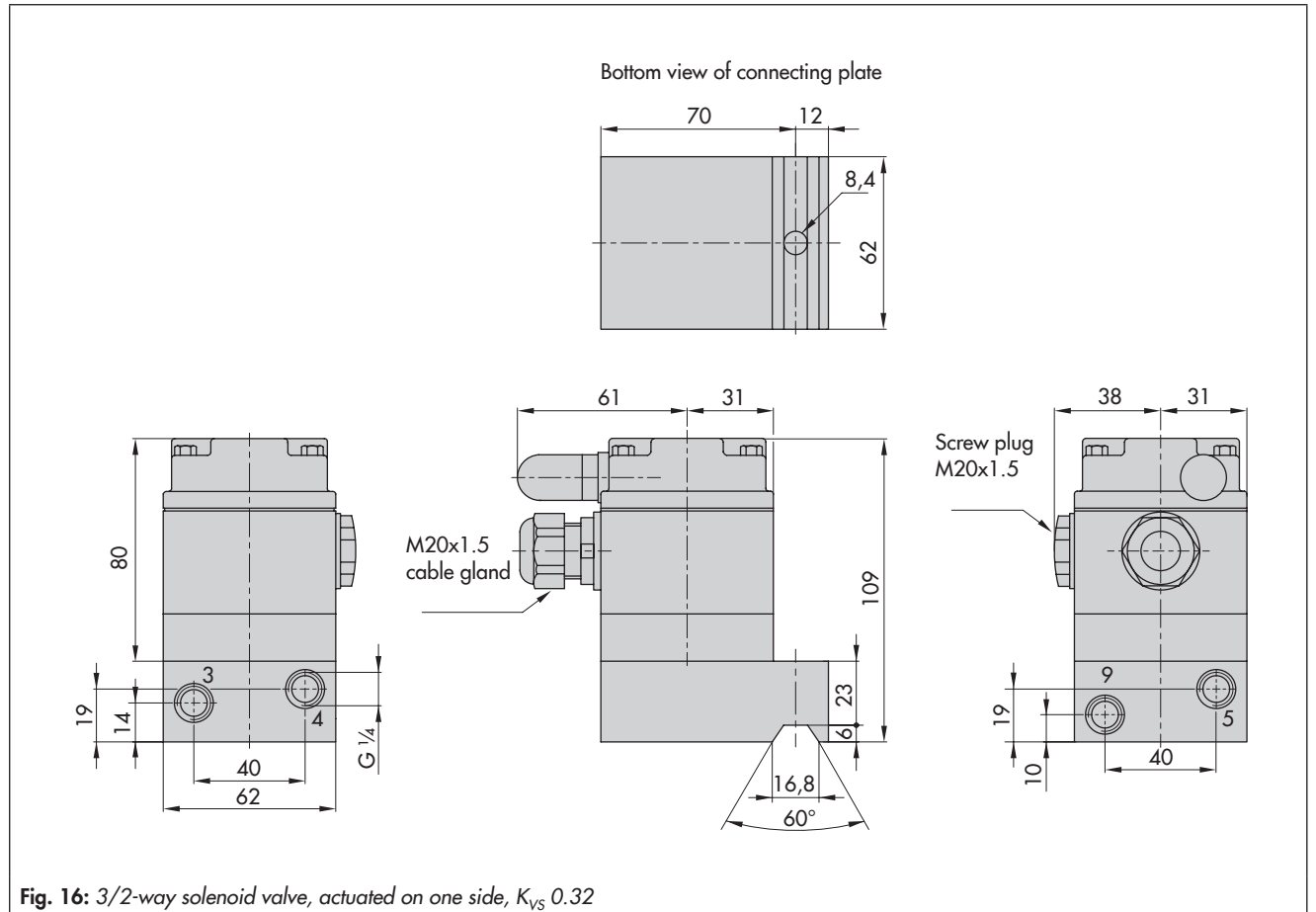

Fig. 15: 5/2 or 5/3-way solenoid valve, actuated on both sides, K_{VS} 1.4



Dimensions of devices with NAMUR interface for rotary actuators

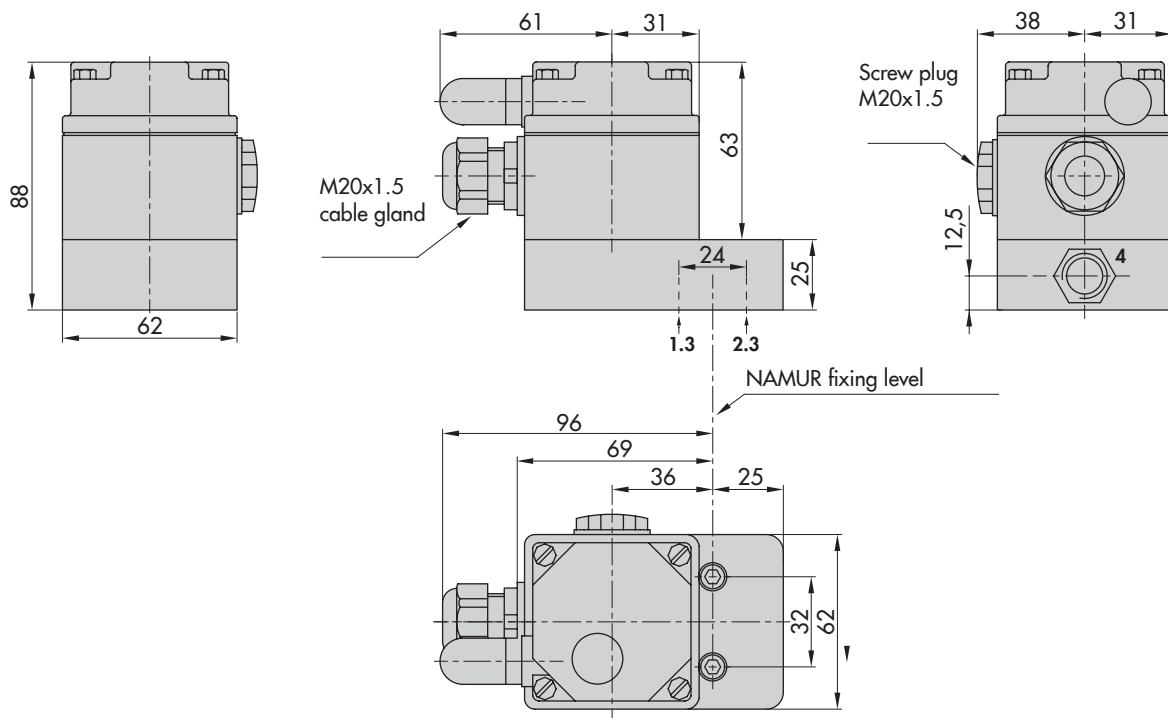

Fig. 18: 3/2 or 5/2-way solenoid valve, actuated on one side, K_{VS} 0.16

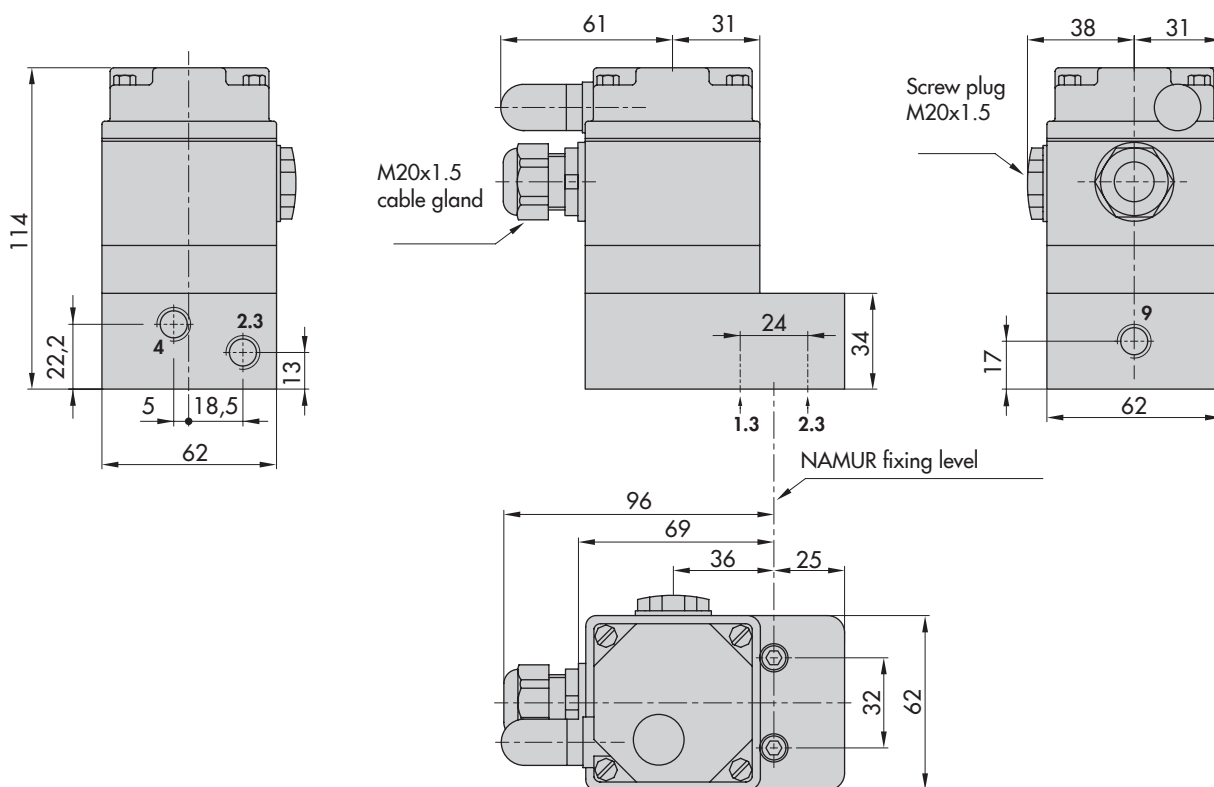

Fig. 19: 3/2-way solenoid valve, actuated on one side, K_{VS} 0.32

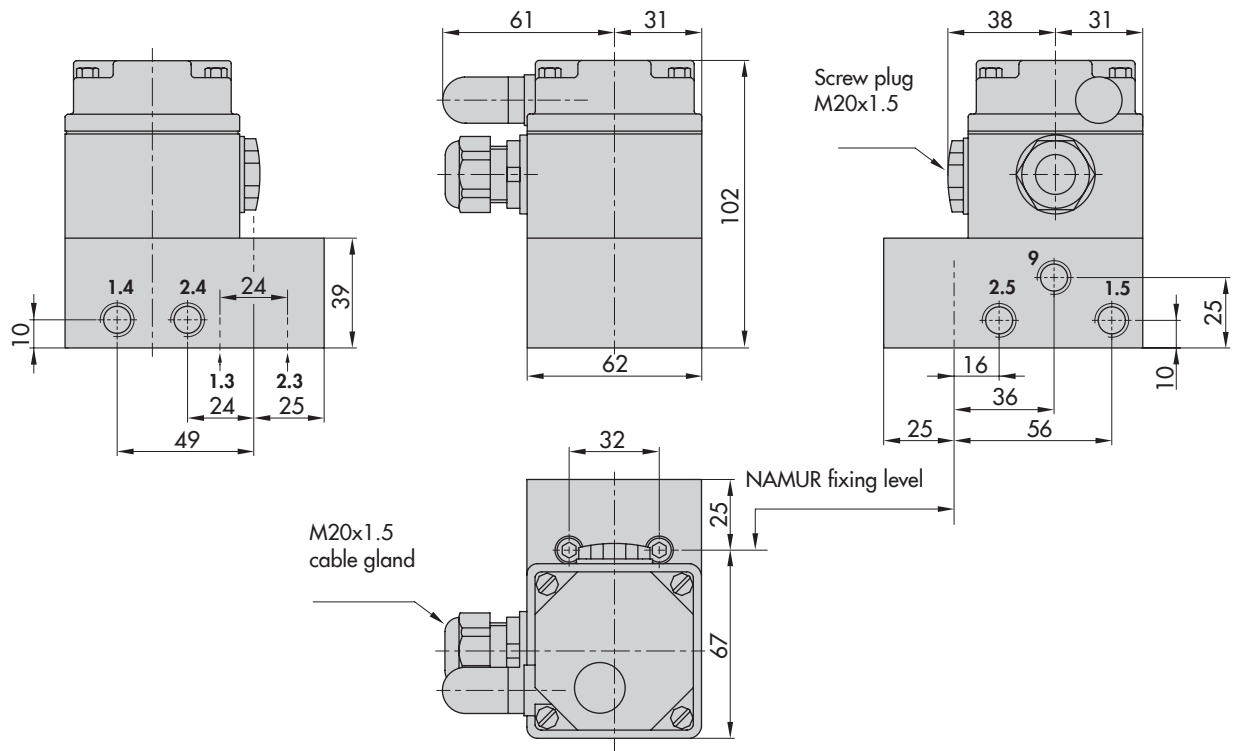

Fig. 20: 6/2-way solenoid valve, actuated on one side, $K_{VS} 0.16$

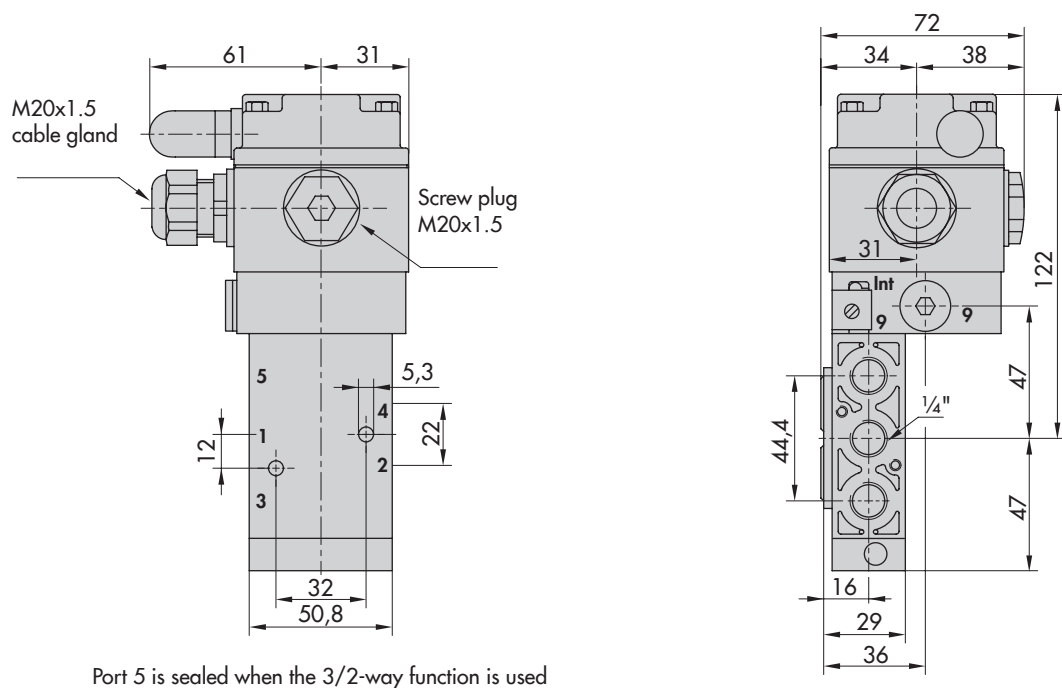

Fig. 21: 3/2 or 5/2-way solenoid valve, actuated on one side, $K_{VS} 1.4$

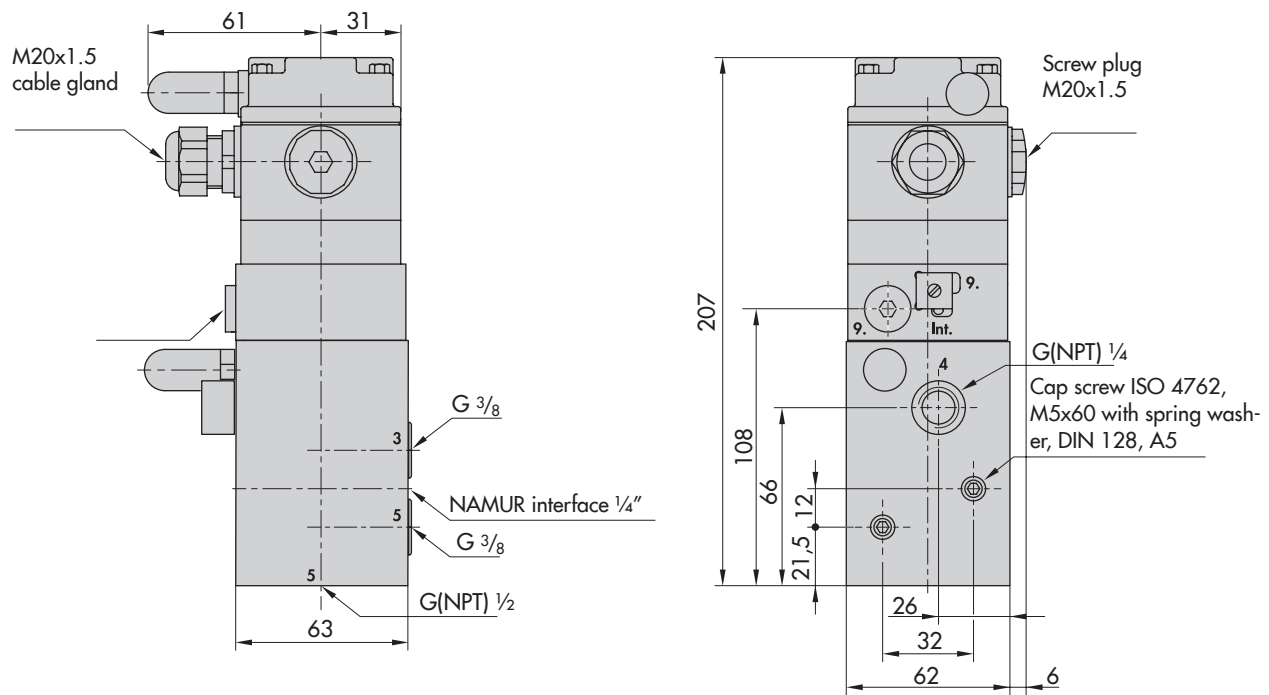

Fig. 22: 3/2-way solenoid valve, actuated on one side, $K_{VS} 2.0$

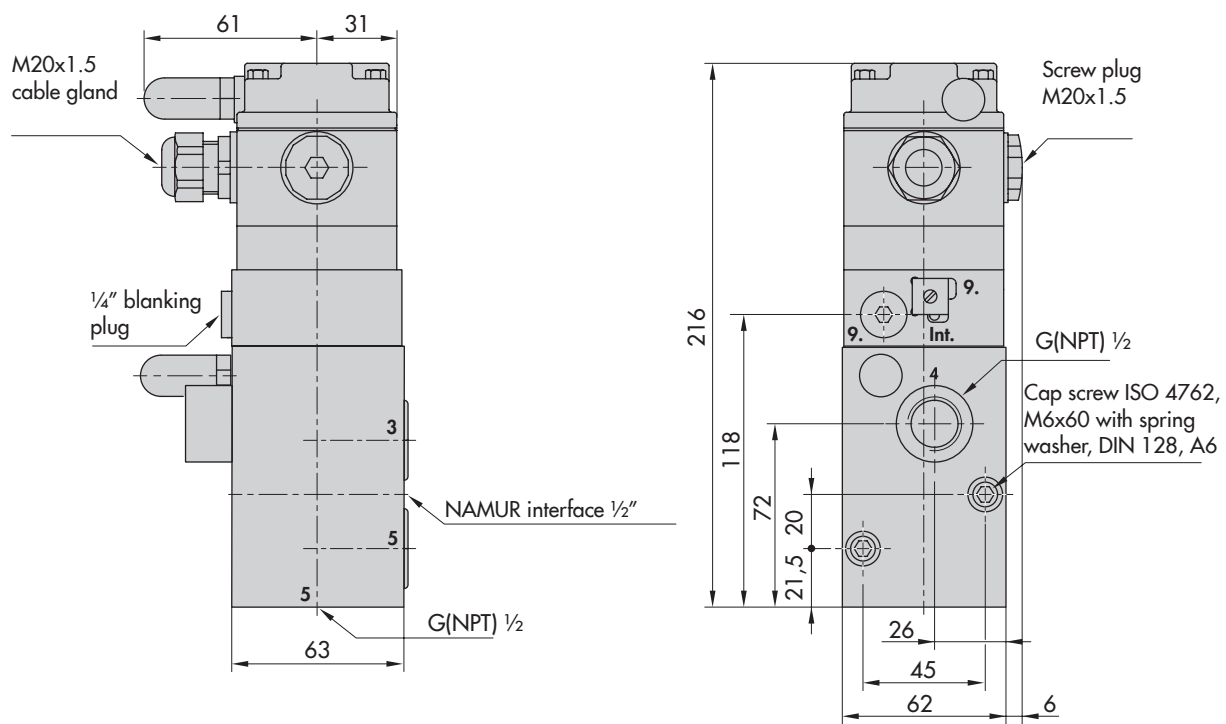

Fig. 23: 3/2-way solenoid valve, actuated on one side, $K_{VS} 4.3$

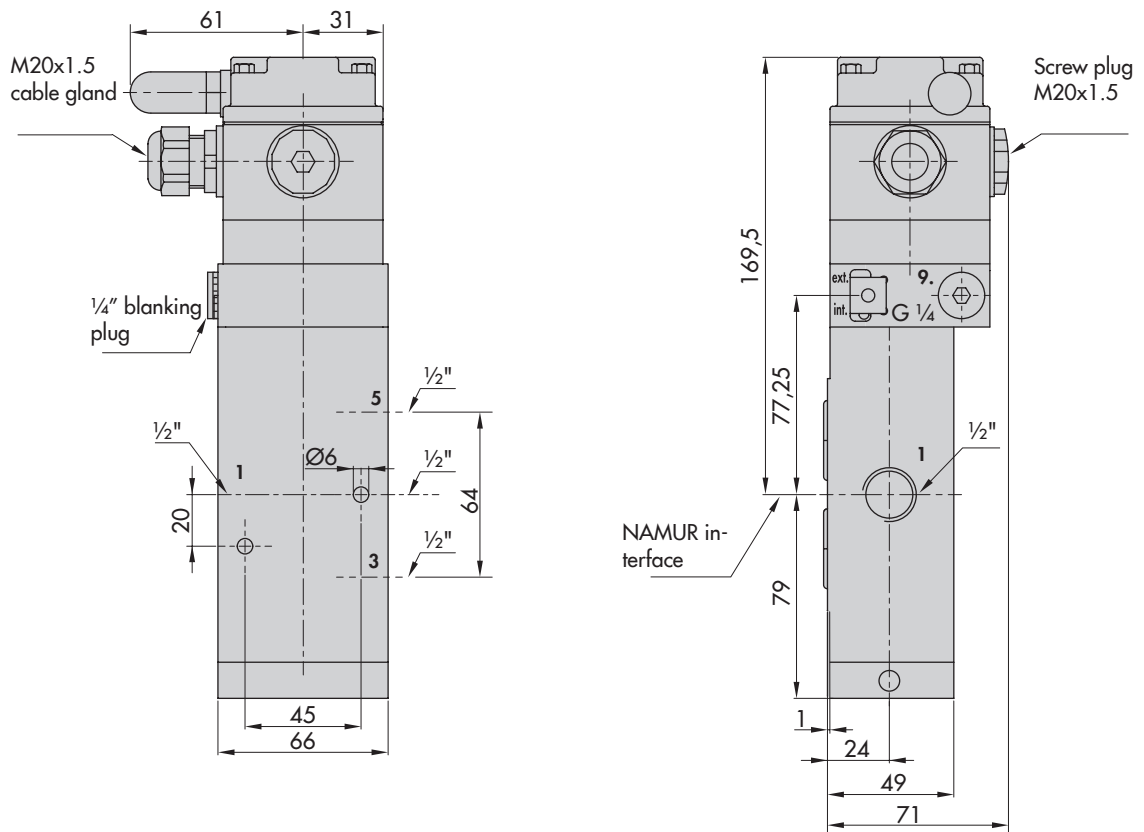

Fig. 24: 5/2-way solenoid valve, actuated on one side, K_{VS} 2.9

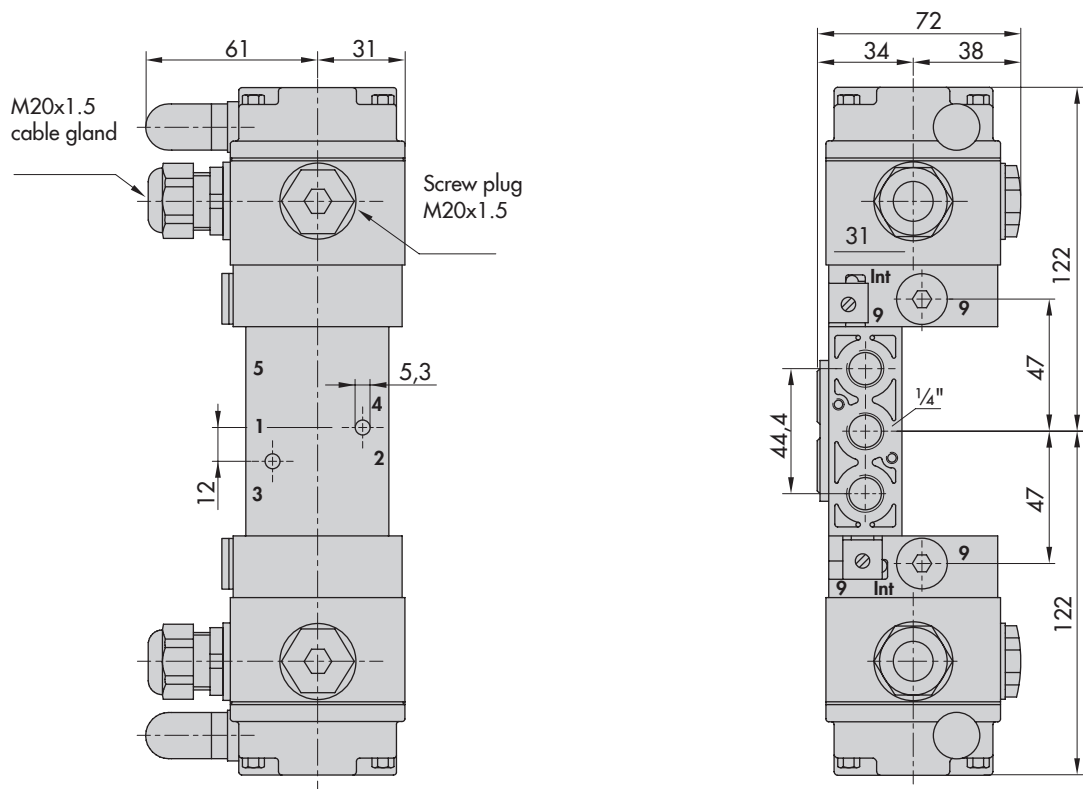

Fig. 25: 5/2 or 5/3-way solenoid valve, actuated on both sides, K_{VS} 1.4

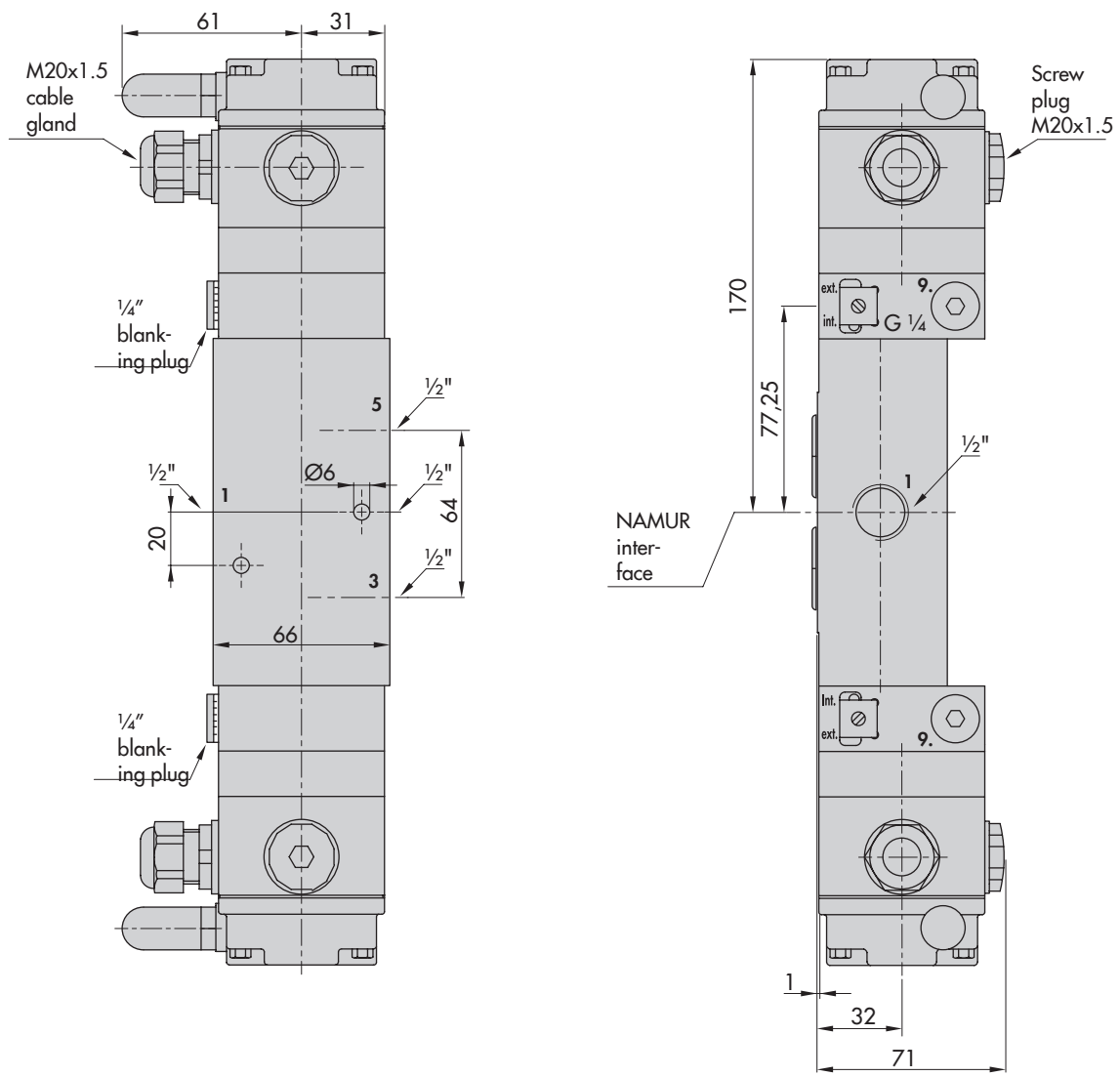

Fig. 26: 5/2-way solenoid valve, actuated on both sides, K_{VS} 2.9

Versions and ordering data

i Note

The "NAMUR interface according to VDI/VDE 3845" version in combination with K_{VS} 0.32 has an Ematal coating (Type 3963-xxxxx02xxxxxxxxxx).

Type 3963 Solenoid Valve	Type 3963-	x	x	x	x	x	x	x	x	x	x	x	x	x	x	x	x	x	x	x
Type of protection																				
No explosion protection	0																			
ATEX ¹⁾ II 2G Ex ia IIC T6...T4 Gb	1																			
CSA Ex ia IIC T6: Class I, Zone 0; Class I, II, Div. 1, Groups A, B, C, D, E, F, G; Class I, II, Div. 2, Groups A, B, C, D, E, F, G	3																			
FM Class I, Zone 0 AEx ia IIC Class I, II, III, Div. 1, Groups A, B, C, D, E, F, G Class I, Div. 2, Groups A, B, C, D; Class II, Div. 2 Groups F, G; Class III; Type 4X	1																			
ATEX ²⁾ II 3G Ex nA II T6 Gc, II 3G Ex ic IIC T6 Gc	8																			
Nominal signal																				
6 V DC, 5.47 mW power consumption	1																			
12 V DC, 13.05 mW power consumption	2																			
24 V DC, 26.71 mW power consumption	3																			
230 V AC, 0.46 VA power consumption (without explosion protection)	5																			
115 V AC, 0.17 VA power consumption (without explosion protection)	6																			
Manual override																				
Without manual override SIL/TÜV	0																			
Pushbutton underneath the enclosure cover SIL/TÜV	1																			
External pushbutton (accessible using a pin)	2																			
External switch (accessible using a screwdriver)	3																			
Switching function																				
3/2-way function with spring-return mechanism SIL/TÜV (all K_{VS} coefficients)	0																			
5/2-way function with spring-return mechanism (K_{VS} 0.16, 1.4, 2.9, 4.3; SIL with K_{VS} 0.16)	1																			
5/2-way function with two detent positions TÜV (K_{VS} 1.4/2.9)	2																			
5/3-way function with spring-centered mid-position (ports 2 and 4 closed, K_{VS} 1.4)	3																			
5/3-way function with spring-centered mid-position (ports 2 and 4 vented) TÜV (K_{VS} 1.4)	5																			
6/2-way function with spring-return mechanism (K_{VS} 0.16, 4.3; SIL with K_{VS} 0.16)	8																			
Restrictors																				
Without restrictors SIL/TÜV (all K_{VS} coefficients)	0																			
One exhaust air restrictor (3/2-way function/NAMUR interface or mounting block/ K_{VS} 0.16)	1																			
Two exhaust air restrictors (5/2-way function/NAMUR interface/ K_{VS} 0.16)	2																			
One supply air/exhaust air restrictor (3/2-way function/NAMUR interface/ K_{VS} 0.16)	3																			
Mounting																				
NAMUR interface according to VDI/VDE 3845 SIL/TÜV (all K_{VS} coefficients) ⁹⁾	0																			
Threaded connection for rail, wall or pipe mounting SIL/TÜV (K_{VS} 0.16, 0.32, 1.4, 4.3)	1																			
NAMUR rib according to IEC 60534-6-1 SIL/TÜV (K_{VS} 0.32)	2																			
Mounting block for Type 3277 Linear Actuator SIL/TÜV (K_{VS} 0.16, 0.32)	3																			
Type 3963 (flange), only as spare part (K_{VS} 0.01/0.16)	4																			
K_{VS} ³⁾																				
0.16 SIL/TÜV	1																			
0.32 SIL/TÜV ⁹⁾	2																			
1.4 TÜV	3																			
4.3 SIL/TÜV	4																			
0.01 (as spare part)	5																			
2.9 (NAMUR interface)	6																			
2.0 SIL/TÜV (NAMUR interface)	7																			

Type 3963 Solenoid Valve	Type 3963- x x x x x x x x x x x x x x x x									
Pneumatic connection										
G ¼ (K _{V5} 0.16, 0.32, 1.4, 2.0)	0									
¼ NPT (K _{V5} 0.16, 0.32, 1.4, 2.0)	1									
G ½ (K _{V5} 2.9, 4.3)	2									
½ NPT (K _{V5} 2.9, 4.3)	3									
Without (pilot valve as spare part/mounting block for Type 3277 Linear Actuator)	4									
Air supply										
Internal pilot supply for actuators for on/off service	0									
External pilot supply for actuators for throttling service	1									
Electrical connection										
Blanking plug M20x1.5	0	0								
M20x1.5 cable gland, black polyamide	0	1								
M20x1.5 cable gland, blue polyamide	1	1								
Adapter M20x1.5 to ½ NPT (aluminum)	1	2								
M20x1.5 cable gland (CEAG), black polyamide	1	3								
M20x1.5 cable gland, nickel-plated brass	1	4								
M20x1.5 cable gland, nickel-plated brass, blue	1	5								
M20x1.5 cable gland (CEAG), blue polyamide	1	6								
M20x1.5 cable gland (Jacob), blue polyamide	1	7								
Device connector according to DIN EN 175301-803, black polyamide ¹⁾	2	3								
Device connector with LED according to DIN EN 175301-803, black polyamide ¹⁾	2	5								
Adapter M20x1.5 to ½ NPT (stainless steel)	2	6								
Degree of protection										
IP 54 with polyethylene filter							0			
IP 65 with filter check valve made of polyamide							1			
IP 65 with filter check valve made of stainless steel							2			
NEMA 4 with filter check valve made of polyamide							4			
NEMA 4 with filter check valve made of stainless steel							5			
IP65 with labyrinth-type vent plug							6			
Ambient temperature ⁵⁾										
-20 to +80 °C							0			
-45 to +80 °C							2			
Safety-instrumented function										
Without							0			
SIL ⁶⁾							1			
TÜV ⁷⁾							2			
Special version ⁸⁾										
Without								0	0	0
Material										
Connecting plate/booster valve enclosure made of 1.4404 on request								0	0	1
Explosion protection										
CCC Ex Ex ia IIC T4 ~ T6								0	0	9
EAC (GOST) 1Ex ia IIC T6...T4 Gb X								0	1	1
KCS Ex ia IIC T6/T5/T4								0	1	3
TR CMU 1055 II 2G Ex ia IIC T6 Gb								0	1	7
TR CMU 1055 II 3G Ex ic IIC T6 Gc; II 3G Ex nA II T6 Gc								0	1	8
Function										
Compatible with adapter plate (open-circuit principle) 1402-0894 (K _{V5} 1.4)								0	1	9

¹⁾ EC type examination certificate PTB 01 ATEX 2085

²⁾ Statement of conformity PTB 01 ATEX 2086 X

³⁾ The air flow rate when p₁ = 2.4 bar and p₂ = 1.0 bar is calculated using the following formula: Q = K_{V5} × 36.22 in m³/h.

⁴⁾ The cable socket is not included in the scope of delivery (see 'Spare parts and accessories').

⁵⁾ The permissible ambient temperature of the solenoid valve depends on the permissible ambient temperature of the components, type of protection and temperature class.

⁶⁾ SIL according to IEC 61508

⁷⁾ Emergency release or locking of compressed air supply

⁸⁾ Further special versions on request

⁹⁾ "NAMUR interface according to VDI/VDE 3845" version in combination with K_{V5} 0.32: with Ematal coating

Summary of explosion protection approvals

Type 3963	Certification		Type of protection
-1	ATEX	Number PTB 01 ATEX 2085 Date 2019-11-18	II 2G Ex ia IIC T6...T4 Gb
	CCC Ex	Number 021322307003631 Date 2021-01-08 Valid until 2026-01-07	Ex ia IIC T4 ~ T6
	EAC (GOST)	Number RU C-DE.HA65.B.00806/20 Date 2020-11-10 Valid until 2025-05-11	I Ex ia IIC T6...T4 Gb X
	KCS	Number 13-KB4BO-0039 Date 2013-01-31 Valid until 2025-01-31	Ex ia IIC T6/T5/T4
	TR CMU 1055	Number ZETC/37/2021 Date 2021-07-26 Valid until 2024-07-25	II 2G Ex ia IIC T6 Gb
Number ZETC/111/2021 Date 2021-08-25 Valid until 2024-08-24			
-3	CSA	Number 1607857 Date 2021-11-30	Ex ia IIC T6: Class I, Zone 0; Class I, II, Div. 1, Groups A, B, C, D, E, F, G; Class I, II, Div. 2, Groups A, B, C, D, E, F, G
	FM	Number 3020228 Date 2015-10-12	Class I, Zone 0 AEx ia IIC Class I, II, III, Div. 1, Groups A, B, C, D, E, F, G Class I, Div. 2, Groups A, B, C, D; Class II, Div. 2 Groups F, G; Class III; Type 4X
-8	ATEX	Number PTB 01 ATEX 2086 X Date 2014-04-17	II 3G Ex nA II T6 Gc II 3G Ex ic IIC T6 Gc
	TR CMU 1055	Number ZETC/37/2021 Date 2021-07-26 Valid until 2024-07-25	II 3G Ex ic IIC T6 Gc II 3G Ex nA II T6 Gc
		Number ZETC/111/2021 Date 2021-08-25 Valid until 2024-08-24	

Spare parts and accessories

Spare parts for Type 3963 Solenoid Valve	
Designation	Order no.
Gasket made of silicone rubber (VMQ), -45 to +80 °C (for connecting plate)	0430-2287
Molded seal (for supply air in booster valves with K _{VS} 1.4)	8502-1091
Diaphragm made of chloroprene rubber (CR), -20 to +80 °C (for booster valve with K _{VS} 2.0 or K _{VS} 4.3)	0520-0620
Diaphragm made of silicone rubber (VMQ), -45 to +80 °C (for booster valve with K _{VS} 2.0 or K _{VS} 4.3)	0520-1128
Switching element, -20 to +80 °C (for booster valve with K _{VS} 2.0 or 4.3)	1180-8311
Switching element, -45 to +80 °C (for booster valve with K _{VS} 2.0 or 4.3)	1180-8553
O-ring 13x3.5, -45 to +80 °C (for NAMUR interface ¼", K _{VS} 1.4)	8421-9002
O-ring 16x2, -20 to +80 °C (for NAMUR interface ¼", K _{VS} 2.0)	8421-0364
O-ring 16x2, -45 to +80 °C (for NAMUR interface ¼", K _{VS} 2.0)	8421-0368
O-ring 24x2, -20 to +80 °C (for NAMUR interface ½", K _{VS} 4.3)	8421-1077
O-ring 24x2, -45 to +80 °C (for NAMUR interface ½", K _{VS} 4.3)	8421-0425
O-ring 28x2, -45 to +80 °C (for NAMUR interface ½", K _{VS} 2.9)	8421-0419
O-ring 26x2, -20 to +80 °C (for booster valve with K _{VS} 2.0 or K _{VS} 4.3)	8421-0085
O-ring 26x2, -45 to +80 °C (for booster valve with K _{VS} 2.0 or K _{VS} 4.3)	8421-0418
O-ring 30x2, -45 to +80 °C (for booster valve with K _{VS} 2.9)	8421-0439
O-ring 36x2, -20 to +80 °C (for booster valve with K _{VS} 2.0, K _{VS} 2.9 or K _{VS} 4.3)	8421-0102
O-ring 36x2, -45 to +80 °C (for booster valve with K _{VS} 2.0 or K _{VS} 4.3)	8421-0101
O-ring 48x1, -20 to +80 °C (for booster valve with K _{VS} 4.3)	8421-0112
O-ring 48x1, -45 to +80 °C (for booster valve with K _{VS} 4.3)	8421-0474
O-ring 48x1.5, -45 to +80 °C (for booster valve with K _{VS} 2.0 or K _{VS} 4.3)	8421-1027
O-ring 48x1.5, -20 to +80 °C (for booster valve with K _{VS} 2.0 or K _{VS} 4.3)	8421-1061
Enclosure cover without filter (for pilot valve)	
Without manual override	1099-0673
With external switch (accessible using a screwdriver)	1099-0674
With external pushbutton (accessible using a pin)	1099-0675
With switch lever (accessible from the outside)	1099-1194
Enclosure cover for start-up	1402-1298
Blanking plug G ¼, 1.4571 (for port 9 at the pilot valve)	0070-0858
Blanking plug ¼ NPT, 1.4571 (for port 9 at the pilot valve)	0070-0862
NBR O-ring 14x1.5 (for blanking plug)	8421-0070

Accessories for Type 3963 Solenoid Valves	
Designation	Order no.
Cable socket according to EN 175301-803, form A, made of polyamide, black, degree of protection IP 65	0790-6658
Cable socket with LED according to EN 175301-803, form A, made of polyamide, black, degree of protection IP 65	1170-4069
Cable socket (Harting), 7-pole, made of aluminum, silver, degree of protection IP 65	1400-8298
Sensor connecting lead, two-wire, 3 m, blue, with angle connector M12x1, 4-pole, degree of protection IP 68	8801-2810
Cable socket (Binder), 7-pole, made of PBT GV, black, degree of protection IP 67	8831-0716
Cable socket M12x1, 4-pole, angled design, made of polyamide, black, degree of protection IP 67	8831-0865
Cable breakage protection with activation delay, enclosure for 35 mm rail mounting, IP 20 (for Type 3963-X1 with 6-V DC nominal signal)	3994-0160
Filter made of polyethylene, G 1/G ½ connection, degree of protection IP 54 (required for actuator size >1400 cm²)	1400-5268
Filter made of polyethylene, G ¼ connection, degree of protection IP 54	8504-0066
Filter made of polyethylene, G ½ connection, degree of protection IP 54	8504-0068
Filter check valve in housing with G ¼ thread made of polyamide, degree of protection IP 65	1790-7408
Filter check valve in housing with G ¼ thread made of 1.4301, degree of protection IP 65	1790-7253
Filter check valve in housing with G ¼ thread made of polyamide, degree of protection NEMA 4	1790-9645
Filter check valve in housing with G ¼ thread made of 1.4301, degree of protection NEMA 4	1790-9646
Mounting base for G-profile rail 32 according to EN 50035 (2 pcs. required)	1400-5930
Mounting base for 35 mm top-hat rail according to EN 50022 (2 pcs. required)	1400-5931
Mounting plate for wall mounting	1400-6726
Vent plug G ¼, polyamide, degree of protection IP 65	1991-0451

Mounting kits for Type 3963 Solenoid Valves with threaded connections	
Designation	Order no.
Mounting kit for linear actuators (175/240 cm² actuator area, G ¼ connection) with pipe fitting, G ¼/G ¼ connection, made of CrNiMo steel	1400-6759
Mounting kit for linear actuators (350/355/700/750 cm² actuator area, G ⅜ connection) with pipe fitting, G ½/G ⅜ connection, made of CrNiMo steel	1400-6735
with pipe fitting, G ¼/G ⅜ connection, made of CrNiMo steel	1400-6761
Mounting kit for linear actuators (1000/1400-60 cm² actuator area, G ¾ connection) with pipe fitting, G ½/G ¾ connection, made of CrNiMo steel	1400-6736
Mounting kit for linear actuators (1400-120/1400-250/2800/2 x 2800 cm² actuator area, G 1 connection) with pipe fitting, G ½/G 1 connection, made of CrNiMo steel	1400-6737
Mounting kit for linear actuators (175/240 cm² actuator area, G ¼ connection) with mounting bracket made of CrNiMo steel and screw fittings for 8x1 pipe, G ¼/G ¼ connection, made of zinc-plated steel	1400-6749
and screw fittings for 8x1 pipe, G ¼/G ¼ connection, made of CrNiMo steel	1400-6750
Mounting kit for linear actuators (350/355/700/750 cm² actuator area, G ⅜ connection) with mounting bracket made of CrNiMo steel and screw fittings for 8x1 pipe, G ¼/G ⅜ connection, made of zinc-plated steel	1400-6738
and screw fittings for 8x1 pipe, G ¼/G ⅜ connection, made of CrNiMo steel	1400-6739
and screw fittings for 12x1 pipe, G ¼/G ⅜ connection, made of CrNiMo steel	1400-6743
and screw fittings for 10x1 pipe, G ¼/G ⅜ connection, made of polyamide	1400-6744
and screw fittings for 10x1 pipe, G ¼/G ⅜ connection, made of polyamide	1400-6745
Mounting kit for linear actuators (700/750 cm² actuator area, G ⅜ connection) with mounting bracket made of CrNiMo steel and screw fittings for 12x1 pipe, G ½/G ⅜ connection, made of zinc-plated steel	1400-6740
and screw fittings for 12x1 pipe, G ¼/G ⅜ connection, made of zinc-plated steel	1400-6741
and screw fittings for 12x1 pipe, G ½/G ⅜ connection, made of CrNiMo steel	1400-6742

Mounting kits for Type 3963 Solenoid Valves with NAMUR interface	
Designation	Order no.
Mounting kit for linear actuators (350/355/700/750 cm ² actuator area, G 3/8 connection) with NAMUR rib using adapter plate for NAMUR rib/interface (order no. 1400-6751)	
and screw fittings for 12x1 pipe, G 1/4/G 3/8 connection, made of zinc-plated steel	1400-6746
and screw fittings for 12x1 pipe, G 1/4/G 3/8 connection, made of CrNiMo steel	1400-6747
and screw fittings for 10x1 pipe, G 1/4/G 3/8 connection, made of polyamide	1400-6748
Mounting kit for linear actuators (175/240 cm ² actuator area, G 1/4 connection) with NAMUR rib using adapter plate for NAMUR rib/interface (order no. 1400-6751)	
and screw fittings for 6x1 pipe, G 1/4/G 1/4 connection, made of zinc-plated steel	1400-6752
and screw fittings for 6x1 pipe, G 1/4/G 1/4 connection, made of CrNiMo steel	1400-6753
and screw fittings for 10x1 hose, G 1/4/G 1/4 connection, made of polyamide	1400-6756
Mounting kit for linear actuators (350/355/700/750 cm ² actuator area, G 3/8 connection) with NAMUR rib using adapter plate for NAMUR rib/interface (order no. 1400-6751)	
and screw fittings for 8x1 pipe, G 1/4/G 3/8 connection, made of zinc-plated steel	1400-6754
and screw fittings for 8x1 pipe, G 1/4/G 3/8 connection, made of CrNiMo steel	1400-6755
and screw fittings for 10x1 pipe, G 1/4/G 3/8 connection, made of polyamide	1400-6757
Mounting kit for linear actuators (175/240 cm ² actuator area, G 1/4 connection) with pipe fitting, G 1/4/G 1/4 connection, made of CrNiMo steel	1400-6759
Mounting kit for Type 3353 Angle Seat Valve With adapter plate for NAMUR interface, 1.4301	1400-3001

Accessories for mounting kits	
Designation	Order no.
Support for NAMUR rib (required when a positioner or limit switch is additionally mounted to the linear actuator for valves up to DN 50)	0320-1416
M8x60 hex screw, A4, DIN 931	8320-0131
Adapter plate with NAMUR rib/NAMUR interface (G 1/4)	1400-6751
Adapter plate with NAMUR rib/NAMUR interface, Ematal coating (1/4 NPT)	1400-9924

Mounting blocks and accessories for mounting solenoid valves to Type 3277 Linear Actuators	
Designation	Order no.
Mounting block for Type 3277 Linear Actuator with mounted Types 3793, 3766, 3767 and 3730 Positioners	
G 1/4 connection	1400-8813
1/4 NPT connection	1400-8814
Pressure gauge mounting block, 1x Output and 1x Supply, made of stainless steel/brass (for mounting block)	1400-6950
Piping for actuator with "stem retracts" fail-safe action	
240 cm ² actuator area, zinc-plated steel	1400-6444
240 cm ² actuator area, CrNiMo steel	1400-6445
350 cm ² actuator area, zinc-plated steel	1400-6446
350 cm ² actuator area, CrNiMo steel	1400-6447
700 cm ² actuator area, zinc-plated steel	1400-6448
700 cm ² actuator area, CrNiMo steel	1400-6449