

Backlash-free Metal Bellows Couplings

GERWAH® AKN

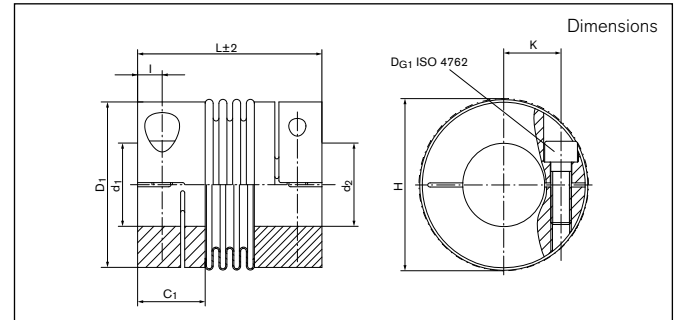

Dimensions

d₁, d_{2min} = Min. bore diameter

d₁, d_{2max} = Max. bore diameter

d_{1k}, d_{2kmin} = Min. bore diameter with keyway acc. to DIN 6885-1

d_{1k}, d_{2kmax} = Max. Min. bore diameter with keyway acc. to DIN 6885-1

C₁ = Guided length in hub boring

D₁ = Outer diameter hub

H = Clearance diameter

I = Distance between center screw hole and hub end

K = Distance shaft axis - clamping screw axis

L = Total length

Size	d ₁ , d ₂ min-max		C ₁	D ₁	H	I	K	L
	Without keyway	With keyway						
	mm	mm	mm	mm	mm	mm	mm	mm
18	8 - 26	8 - 26	20	45	48	6	18	63
30	10 - 30	10 - 30	25	55	56	8	20	65
60	12 - 35	12 - 35	29	64	67	10	24	78
80	14 - 42	14 - 42	33	80	84	12	28	90
150	14 - 42	14 - 42	33	80	84	12	28	90
200	22 - 46	22 - 46	38	90	93	13	31	99
300	24 - 60	24 - 60	38	110	110	13	39	104
500	35 - 64	35 - 64	41	119	122	15	43	111

Transmission of the couplings transmissible torque T can not longer be guaranteed for certain with borings < d_{min}. Types with borings < d_{min}, however, can be supplied.

Moment of inertia and weight (mass) are calculated with reference to the largest bore size.

To continue see next page

Backlash-free Metal Bellows Couplings
GERWAH® AKN
Technical Data

T = Transmissible torque at given T_A
 n_{max} = Max. rotation speed
 C_{Tdyn} = Dynamic torsional stiffness
 C_r = Radial spring stiffness

C_a = Axial spring stiffness
 ΔKa = Max. permissible axial misalignment
 ΔKw = Max. permissible angularly misalignment
 ΔKr = Max. permissible radial misalignment

J = Total moment of inertia
Gw = Weight
 D_{G1} = Thread diameter
 T_{A1} = Tightened torque of clamping screw (G1)

Size	T	n_{max}	C_{Tdyn}	C_r	C_a	ΔKa	ΔKw	ΔKr	J	Gw	D_{G1}	T_{A1}
	Nm	1/min	10^3 Nm/rad	N/mm		mm	Degree	mm	10^{-3} Kgm ²	kg	mm	Nm
18	22	12700	8	200	50	0,5	1,5	0,2	0,05	0,133	1 x M5	6
30	36	10200	35	720	50	0,4	1	0,1	0,11	0,245	1 x M6	12
60	75	8600	75	1100	90	0,4	1	0,1	0,29	0,406	1 x M8	30
80	95	6800	130	1200	80	0,4	1	0,2	0,87	0,742	1 x M10	60
150	180	6800	150	2000	150	0,4	1	0,2	0,87	0,742	1 x M10	85
200	240	6300	170	2500	150	0,4	1	0,2	1,44	1,054	1 x M12	100
300	360	5900	500	6300	280	0,4	1	0,2	3	1,434	1 x M12	120
500	600	4900	680	8800	100	0,5	1	0,2	4,7	1,949	1 x M14	190

Transmissible torque T [Nm]

Size	Ø8	Ø9	Ø10	Ø11	Ø12	Ø13	Ø15	Ø16	Ø18	Ø20	Ø22	Ø25	Ø28	Ø30	Ø35	Ø40	Ø45	Ø50	Ø55	Ø60	Ø64	
18	18	20	22	22	22	22	22	22	22	22	22	22	---	---	---	---	---	---	---	---	---	---
30	---	---	36	36	36	36	36	36	36	36	36	36	36	36	---	---	---	---	---	---	---	---
60	---	---	---	---	75	75	75	75	75	75	75	75	75	75	75	---	---	---	---	---	---	---
80	---	---	---	---	---	---	95	95	95	95	95	95	95	95	95	95	---	---	---	---	---	---
150	---	---	---	---	---	---	180	180	180	180	180	180	180	180	180	180	---	---	---	---	---	---
200	---	---	---	---	---	---	---	---	---	---	240	240	240	240	240	240	240	---	---	---	---	---
300	---	---	---	---	---	---	---	---	---	---	---	360	360	360	360	360	360	360	360	360	360	---
500	---	---	---	---	---	---	---	---	---	---	---	---	---	---	600	600	600	600	600	600	600	600

Ordering example: AKN

Series/Size	Bore diameter d_1	Bore diameter d_2	Further details
AKN 150	30	35	*

* Keyway or stainless steel