

Oilgear

PVM Open Loop Pumps



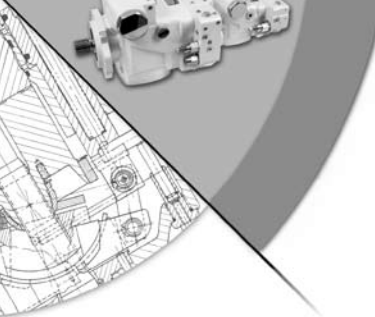

Table of Contents

Performance Assurance	page 3
Features and Benefits	4-5
Specifications	6
Dimensions and Weights	7
Pressure Pick-ups	7
Controls	
Pressure Compensator	8
Standard Load Sense w/Pressure Compensator Override	8
Proportional Electrohydraulic Pressure Compensator	8
Inverse Proportional Electrohydraulic Pressure Compensator	8
Adjustable Load Sense w/Pressure Compensator Override	9
Adjustable Load Sense w/Pressure Bleed-off & Pressure Compensator Override	9
Soft Start Pressure Compensator	9
Remote Pressure Compensator	10
Performance Curves	
Efficiency, Delivery, Horsepower, Etc.	11-13
Sound	14-16
Inlet Suction/Supercharge	17-22
Multiple Pumps	
Pump Combinations	22
Ordering Information	23

PERFORMANCE ASSURANCE – STANDARD WITH EVERY OILGEAR COMPONENT



Oilgear
PERFORMANCE
ASSURANCE

Every Oilgear product is shipped to you with our Performance Assurance — a corporate commitment to stay with your installation until our equipment performs as specified.

Hydraulic equipment and systems have been Oilgear's primary business since 1921. For decades, we have developed hydraulic techniques to meet the unique needs and unusual fluid power problems of machinery builders and users worldwide, matching fluid power systems to a tremendous range of applications and industries. Our exclusive Performance Assurance program is built upon that strong foundation.

As a customer, you also benefit from access to Oilgear's impressive technical support network. You'll find factory trained and field-experienced application engineers on staff at every Oilgear facility. They are backed by headquarters staff who can access the records and knowledge learned from decades of solving the most difficult hydraulic challenges.

When your design or purchase is complete, our service is just beginning. If you ever need us, our Oilgear engineers will be there, ready to help you with the education, field service, parts and repairs to assure that your installation runs smoothly—and keeps right on running.

Oilgear Performance Assurance

PVM Open Loop Pumps

Multiple controls available

- A fast shift valve assists pump in coming back on stroke
- All units are shipped with "meter-out" pressure compensated, load sensing control
- Delivers high performance in a compact package

Cylinder mounted in polymerous hydrodynamic journal bearings

- Allows operation with low viscosity or other special fluids
- Provides infinite bearing life
- Enables compact design

Rugged cylinder design

- Hardened nodular iron construction for improved performance and contamination resistance

Hardened cylinder surfaces

- Greater resistance to contamination
- Provides longer life
- Allows operation with low viscosity or other special fluids

Rotation Convertibility

- Right-hand driven pumps are easily converted to left-hand driven pumps or vice versa
- Constant port locations (suction, pressure) regardless of pump rotation

Valve plate selection

- Rear or top and bottom port connections available

SAE Splined or Keyed shaft

- For convenient coupling to your specific rotary power source, heavy-duty shafts allow high through torque capability

Quiet port plate design

- Minimizes noise at typical electric and drive motor speeds
- Low sound levels (see Sound Curves)
- Allows easy inspection and maintenance

One piece polymerous bearing

- Allows running on low viscosity or other special fluids
- Permits constant control reaction with low hysteresis
- Allows high performance in high cyclic applications
- Eliminates troublesome yoke bearings
- Provides long life

Patented pressure lubricated swashblock

- Delivers high performance for high pressure high cycle operation
- Provides long life

Hardened steel shoes with specially designed face for increased fluid retention, running on hardened swashblock surface

- Running surfaces hardened
- Provides a higher degree of contamination resistance
- Allows higher pressure operation
- Enables operation with low viscosity or other special fluids
- Provides long life

Through-shaft availability (after removal of rear cover)

- Full through-shaft torque capability for most units (see Multiple Pump Combinations, Page 22) allows multiple pump installation from single driveshaft
- Close-coupled dual design further provides a compact package
- Has provisions for mounting other SAE size pumps, equipment etc.
- Can be used to drive auxiliary devices (see Multiple Pump Combinations, Page 22)

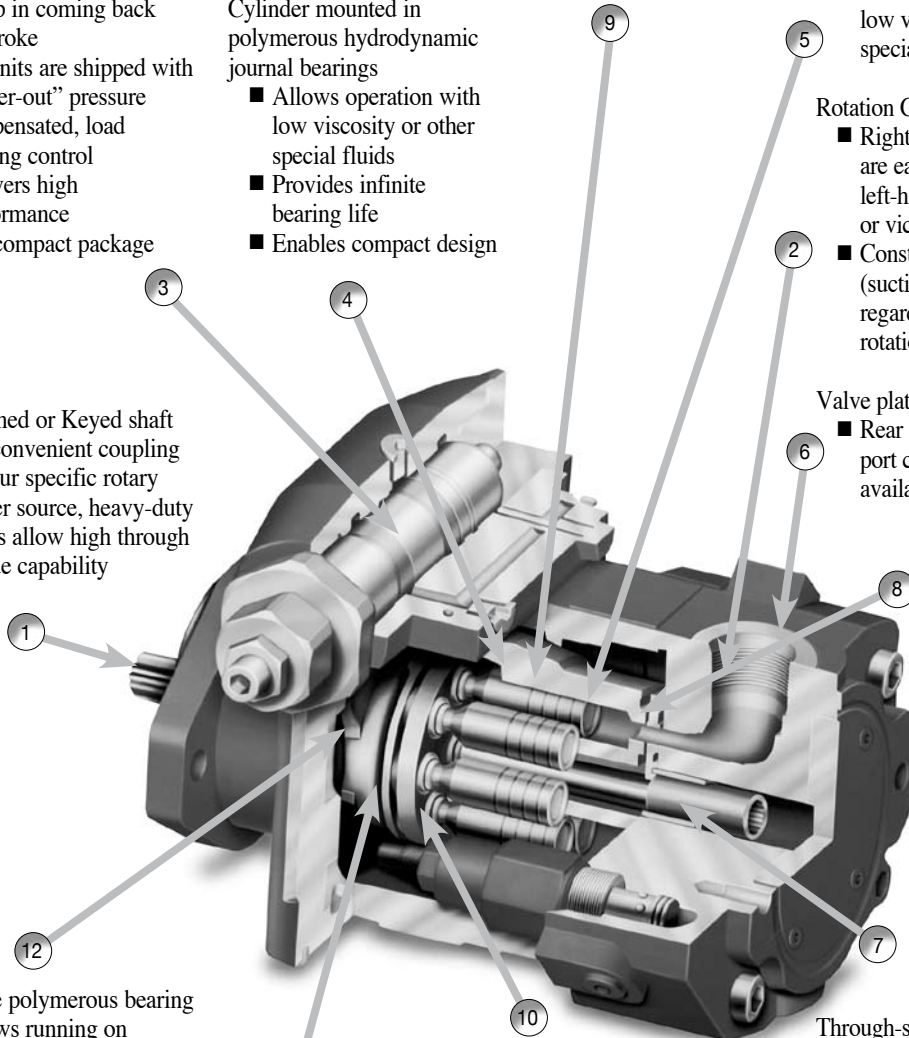

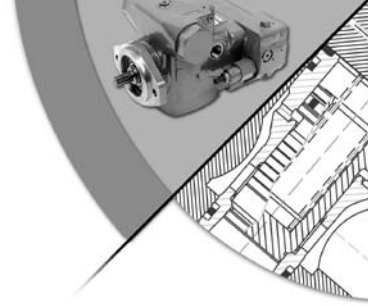

Plus the following not shown in the cross section photo

- (13) Isolated front shaft bearing
 - Enables operation with low viscosity or other special fluids
 - Allows side loading
- (14) Multiple capacities in each compact frame size
 - Permits selection of volume capacity that most closely match your needs while providing maximum control range
 - Unitized one-piece nodular iron housing reduces number of potential leak paths
- (15) Totally enclosed
 - Impervious to high pressure washdown
 - Can be operated in hazardous environments with totally enclosed drive motors
- (16) Can be easily mounted in any position
 - Easy to install
 - Dual case drain available for mounting flexibility
- (17) Built in purge port
 - Aids in purging trapped air from pump during start-up
- (18) Designed without gaskets
 - All mating surfaces and passages designed with o'ring seals to prevent leakage

Oilgear Features and Benefits

SPECIFICATIONS

Nominal Performance Data with 150-300SSU viscosity fluids

FRAME SIZE	UNIT SIZE	THEORETICAL MAXIMUM DISPLACEMENT		RATED CONTINUOUS PRESSURE		MAXIMUM PRESSURE		FLOW RATE at 1800 rpm, rated continuous pres. & 14,7 psia (1.0 bar) inlet condition		MINIMUM INLET PRESSURE psia (bar)			MAXIMUM SPEED rpm.	POWER INPUT at rated cont. pres. & 1800 rpm	
		in ³ /rev.	ml/rev.	psi	bar	psi	bar	gpm	l/min	1200rpm	1500rpm	1800rpm		hp	kw
A	011	0.66	10,8	3750	258,6	4250	293,1	4.3	16,3	5.0 (.34)	5.3 (.37)	5.6 (.39)	3600	12.8	9.5
	014	0.86	14,1	3750	258,6	4250	293,1	5.8	22,0	5.0 (.34)	5.0 (.34)	5.5 (.38)	3600	16.4	12.1
	022	1.35	22,1	3750	258,6	4250	293,1	9.5	36,0	6.6 (.46)	7.6 (.52)	8.6 (.60)	3600	26.1	19.5
B	025	1.55	25,4	3750	258,6	4250	293,1	10.1	38,2	5.0 (.34)	5.0 (.34)	6.5 (.45)	2700	28.8	21.5
	034	2.06	33,8	3750	258,6	4250	293,1	14.1	53,4	5.0 (.34)	5.0 (.34)	5.7 (.40)	2700	37.7	28.1
	046	2.83	46,4	3750	258,6	4250	293,1	19.7	74,6	5.0 (.34)	5.0 (.34)	5.7 (.40)	2400	51.9	38.7
	065	4.00	65,5	3750	258,6	4250	293,1	27.9	105,6	5.0 (.34)	5.0 (.34)	6.2 (.43)	2700	71.0	52.9
	075	4.61	75,5	3750	258,6	4250	293,1	31.3	118,5	5.0 (.34)	5.0 (.34)	6.5 (.45)	2700	83.8	62.5
C	064	3.88	63,6	3750	258,6	4250	293,1	26.6	100,7	6.1 (.42)	6.2 (.43)	7.3 (.50)	2450	70.2	52.4
	076	4.67	76,5	3750	258,6	4250	293,1	32.4	122,6	6.2 (.43)	6.3 (.43)	8.2 (.57)	2450	85.7	63.9
	098	6.00	98,3	3750	258,6	4250	293,1	41.2	156,0	6.7 (.46)	7.1 (.49)	8.3 (.57)	2450	109.2	81.4
	130	7.94	130,2	3750	258,6	4250	293,1	57.8	218,8	6.7 (.46)	7.1 (.49)	8.7 (.60)	2450	150.8	112.5

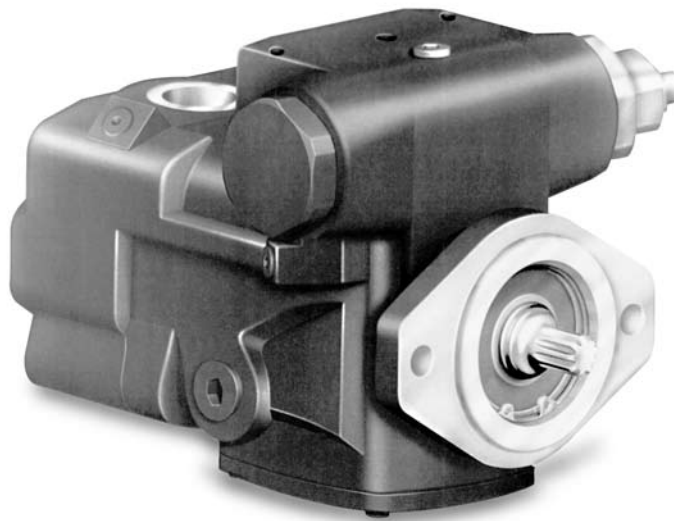

SINGLE PUMP



Nominal Dimensions

FRAME SIZE	UNIT SIZE	LENGTH		WIDTH		HEIGHT		WEIGHT		FACE MOUNT
		in.	mm.	in.	mm.	in.	mm.	lbs.	kg	
A	011, 014 & 022	7.95	201,9	7.28	184,9	6.63	168,4	37.5	17,0	SAE "A" 2 Bolt
B	025, 034 & 046 065 & 075	9.51	241,5	9.00	228,6	8.88	225,6	73.0	33,1	SAE "B" 2/4 Bolt
		10.00	254,0	9.03	229,4	8.88	225,6	75.0	34,0	
C	064, 076, 098 & 130	11.91	302,5	10.73	272,5	10.45	265,4	136.0	61,7	SAE "C" 2/4 Bolt

DUAL PUMP



Nominal Dimensions

FRAME SIZE	LENGTH		WIDTH		HEIGHT		WEIGHT	
	in.	mm.	in.	mm.	in.	mm.	lbs.	kg
A/A	16.20	410,5	7.28	184,9	6.63	168,4	77.0	35,0
B/A	18.31	465,1	9.03	229,4	8.88	225,6	115.5	52,5
B/B	20.36	517,1					153.0	69,5
C/A	20.33	516,4	10.73	272,5	10.45	265,4	183.5	83,4
C/B	22.38	568,5					221.0	100,5
C/C	24.29	617,0					282.0	128,2

PRESSURE PICK-UP POINTS FOR INSTRUMENTATION

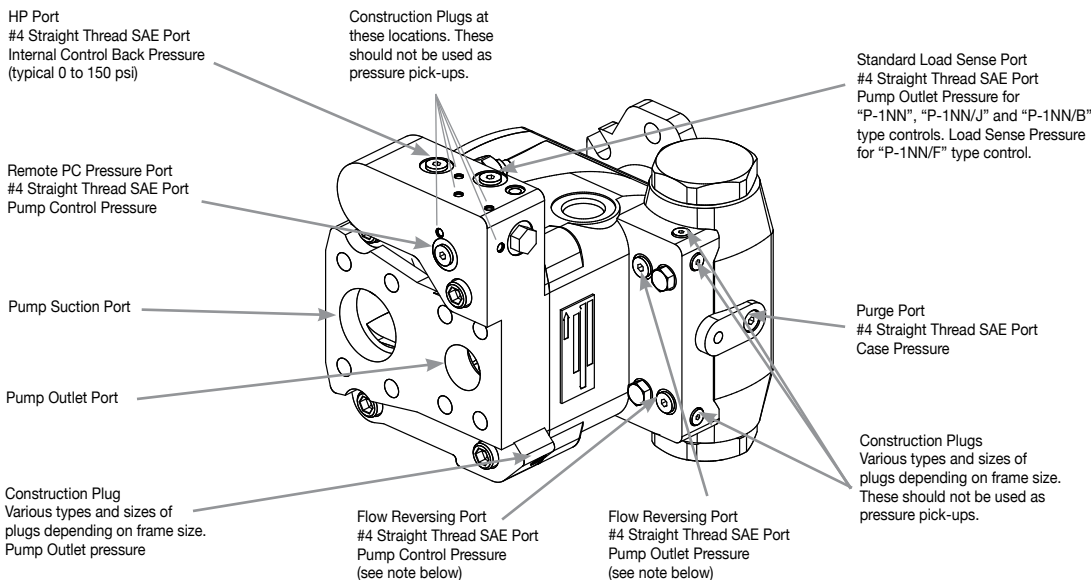

Note: Right-hand Pump shown.
Pressure pick-ups at Flow Reversing Ports are reversed for Left-hand units.

Pump Outlet Pressure = Pressure at Outlet of Pump

Pump Control Pressure = Pump Outlet Pressure when pump is at full stroke, will be 150 to 200 psi less than Pump Outlet Pressure when pump control(s) are reducing outlet flow.

Pump Controls*

PRESSURE*

Pressure Compensator "P-1NN"

Ensures maximum pump flow until unit reaches preset control pressure setting and then regulates output flow to match the requirements of the system while maintaining preset output pressure. Pressure can be adjusted from 350 psi (24,1 bar) working pressure up to the rated pressure of the pump.

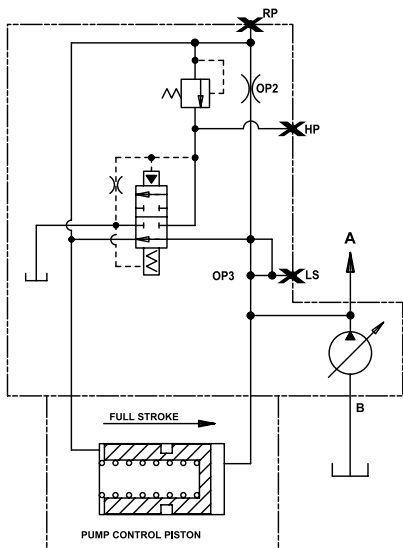

PUMP CONTROLS* Any, single or multiple, combination of remote or load sense controls can be combined with the built-in pressure compensator control if desired.

Standard Load Sense w/Pressure Compensator "P-1NN/F"

A constant output flow is maintained for a given (customer supplied) flow control valve setting regardless of changes in drive speed and/or working pressure. The load sense differential is 180 psi (12,4 bar) and is not adjustable.

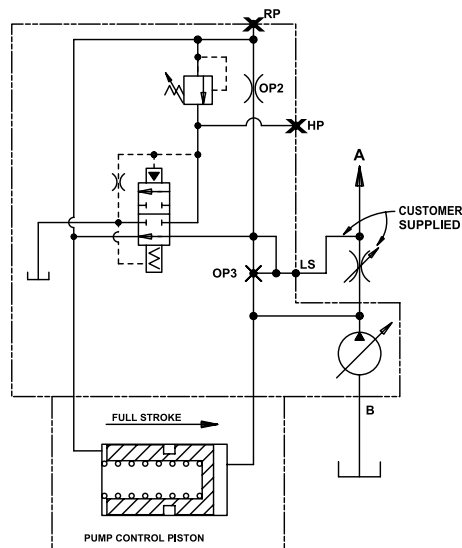

Proportional Electronic Pressure Compensator "P-AXX"

Pressure compensator setting increases proportionally with an electrical input signal. Pressure can be adjusted from 350 to 3750 psi (24,1 to 259 bar). A manually adjustable override valve is used to set the maximum pressure settings.

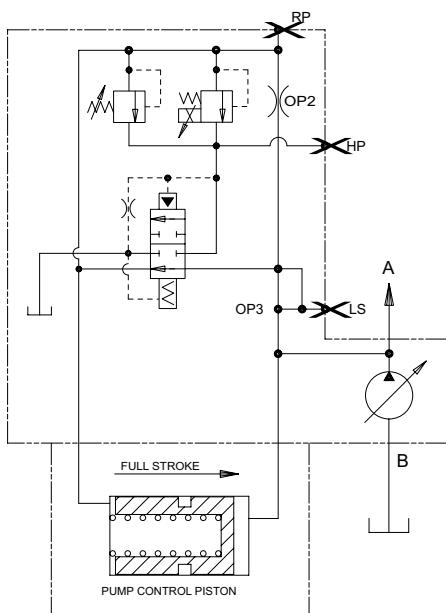

Inverse Proportional Electronic Pressure Compensator "P-BXX"

Pressure compensator setting decreases proportionally with an electrical input signal. Pressure can be adjusted from 350 to 3750 psi (24,1 to 259 bar). A manually adjustable override valve is used to set the maximum pressure setting. Generally used for fan drive circuits.

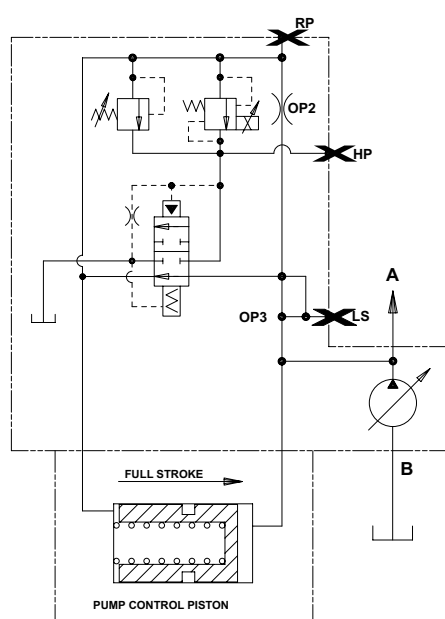

* Be sure system and pumps are protected, with a high-pressure relief valve, against overloads. For detailed circuits of a particular size pump and control combination, contact your Oilgear Representative.

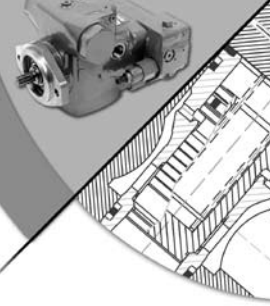

Oilgear Pump Controls*

Adjustable Load Sense w/Pressure Compensator Override "P-1NN/J"

Adjustable load sense w/pressure compensator "P-1NN/J." A constant output flow is maintained for a given (customer supplied) flow control valve setting regardless of changes in drive speed and/or working pressure. The load sense differential is adjustable from 180 to 700 psi (12,4 to 48,3 bar).

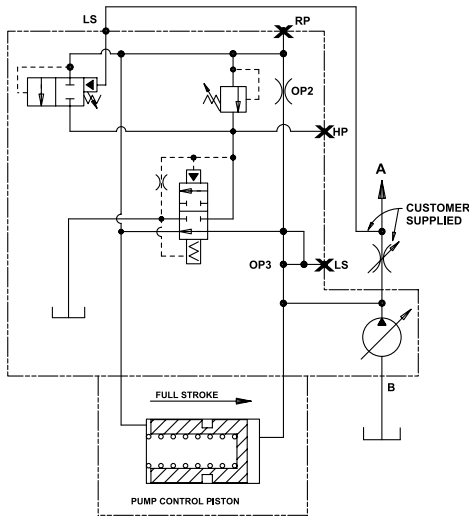

Adjustable Load Sense w/Pressure Bleed-off & Pressure Compensator Override "P-1NN/B"

Same as "P-1NN/J" except with an internal orifice to vent load sense pressure to drain when the load sense is not active or during shutdown. The load sense differential is adjustable from 180 to 700 psi (12,4 to 48,3 bar).

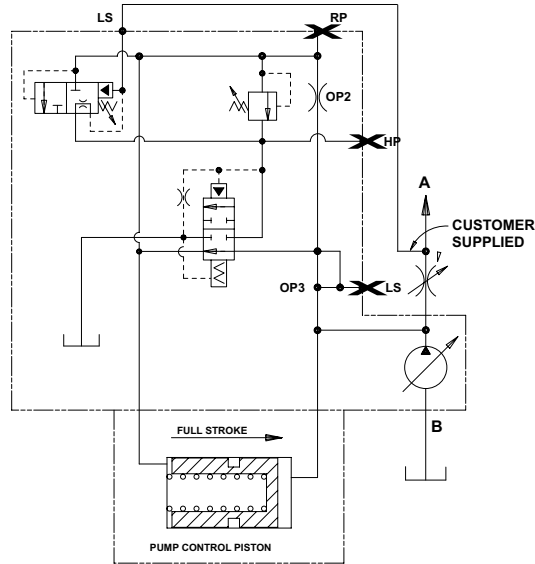

Soft Start Pressure Compensator "P-CNN"

Pump starts "softly" by going quickly at low pressure to a reduced flow setting, thereby reducing start-up torque requirement. The "P-CNN" control uses a normally open cartridge that will unload the pump at the minimum pressure setting with no power to the solenoid.

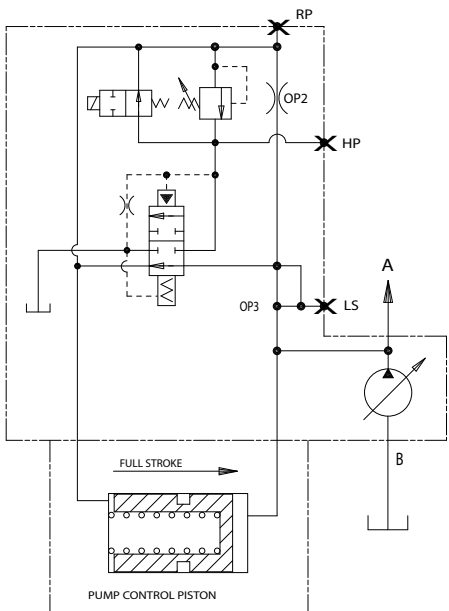

Soft Start Pressure Compensator "P-KNN"

Pump starts "softly" by going quickly at low pressure to a reduced flow setting, thereby reducing start-up torque requirements. The "P-KNN" control uses a normally closed cartridge that will unload the pump at the minimum pressure setting with the solenoid energized.

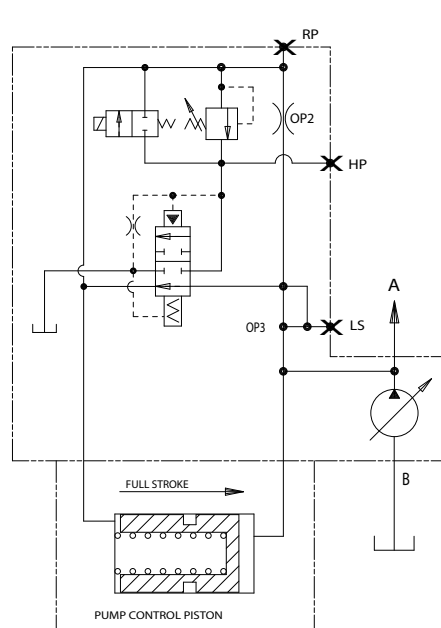

* Be sure system and pumps are protected, with a high-pressure relief valve, against overloads. For detailed circuits of a particular size pump and control combination, contact your Oilgear Representative.

Remote Controls for Pressure Compensator Functions

A customer-supplied remote control valve can be easily added to any of the "PVM" pumps allowing pressure adjustment control to be convenient to the operator while the pump may be located convenient to the operated device.

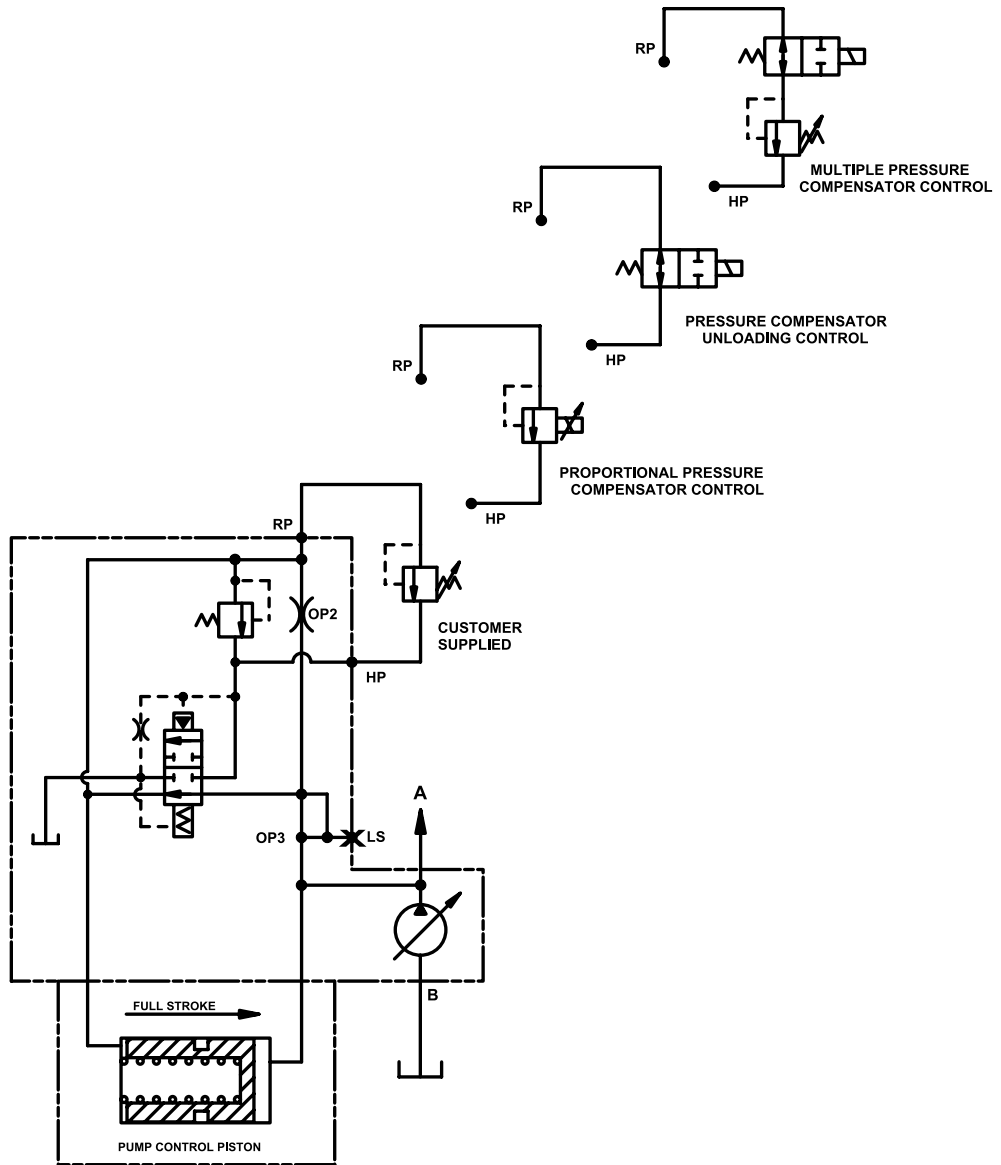

Note: RP (Remote Pressure) lines of multiple pumps cannot be tied together for unloading or controlling with a common remote pressure control valve. A dedicated valve is required for each pump.

For remote pressure control of multiple pumps, see data sheet 47974.

PERFORMANCE

Performance curves are based on a viscosity of 160 SSU.

■ PVM-011

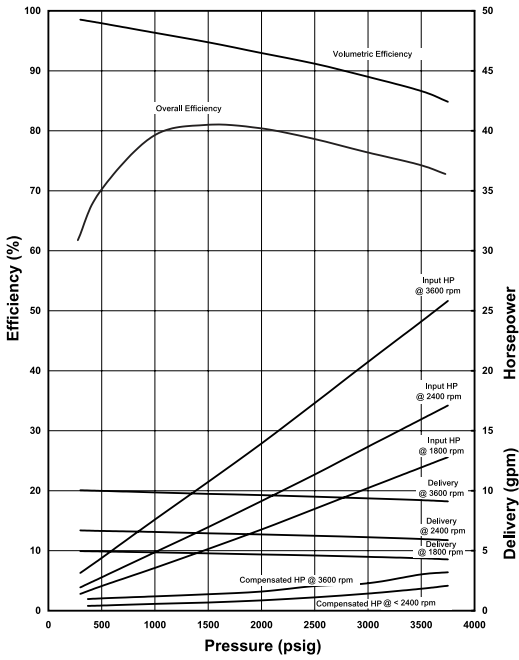

■ PVM-014

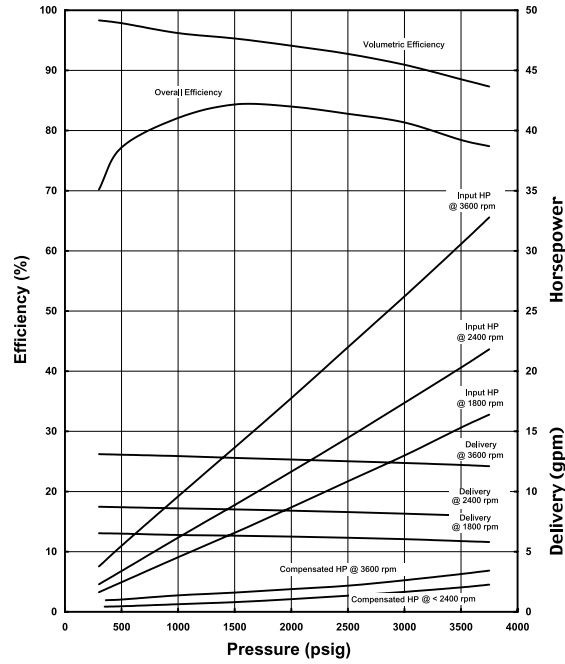

■ PVM-022

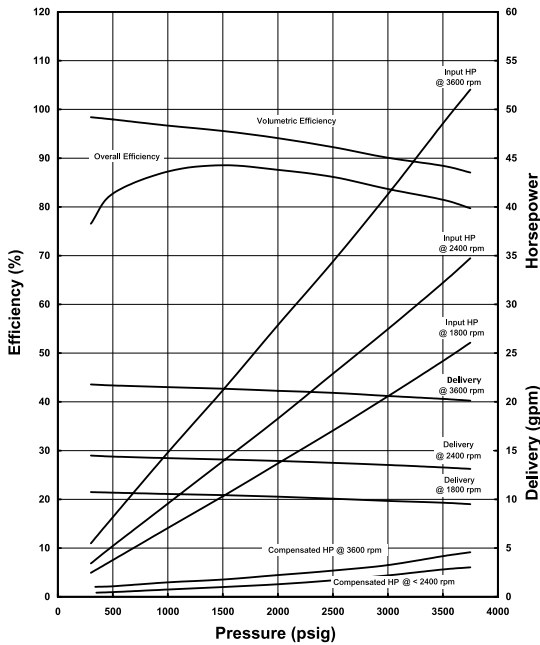

■ PVM-025

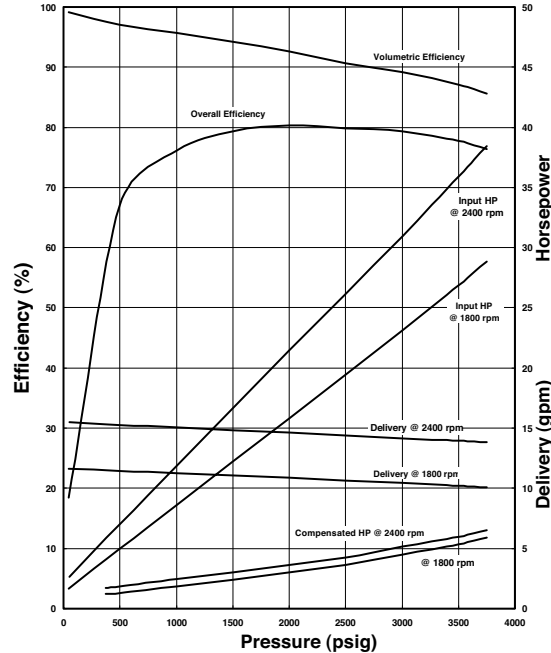

Oilgear Performance Curves

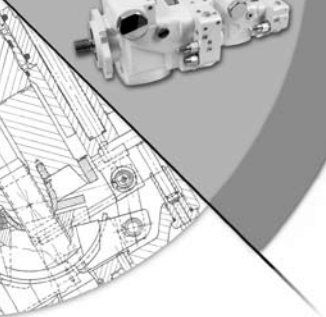

Performance curves are based on a viscosity of 160 SSU.

■ PVM-034

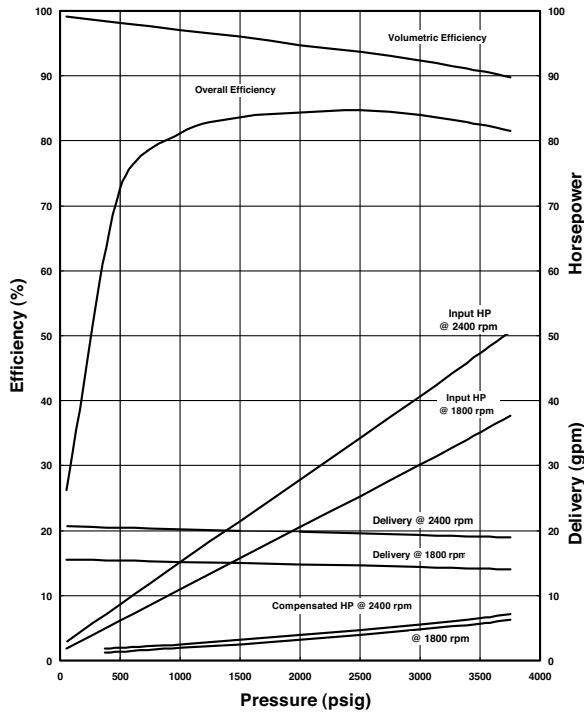

■ PVM-046

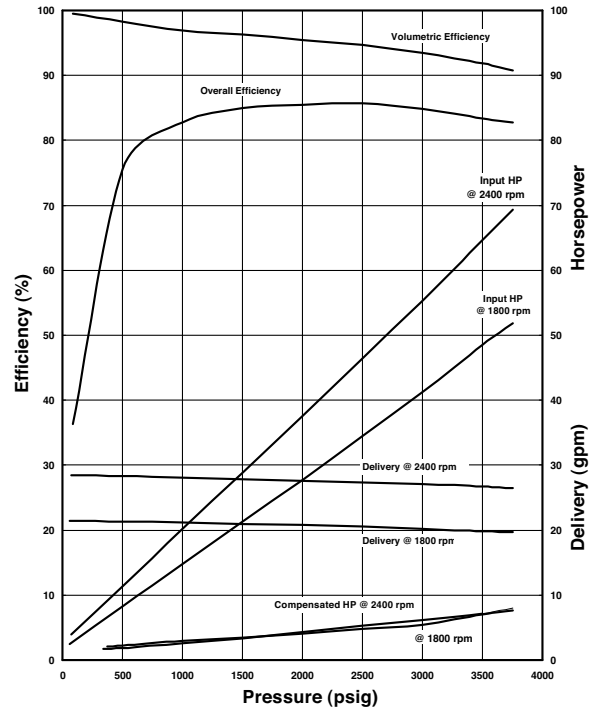

■ PVM-064

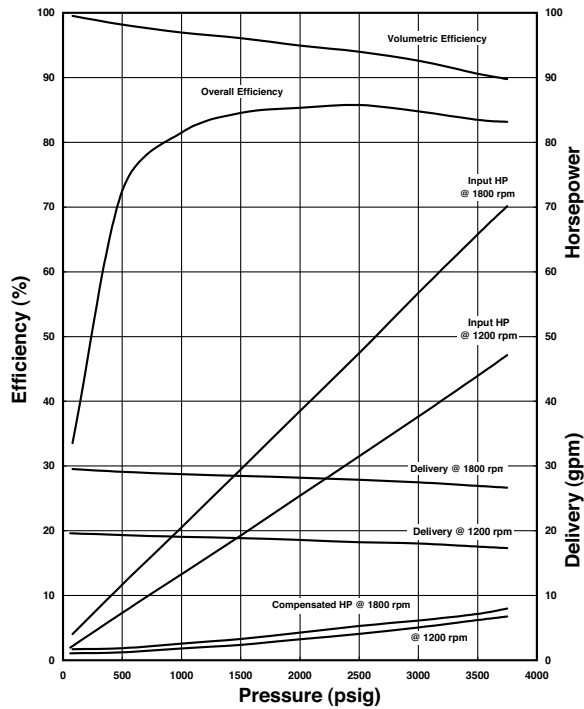

■ PVM-065

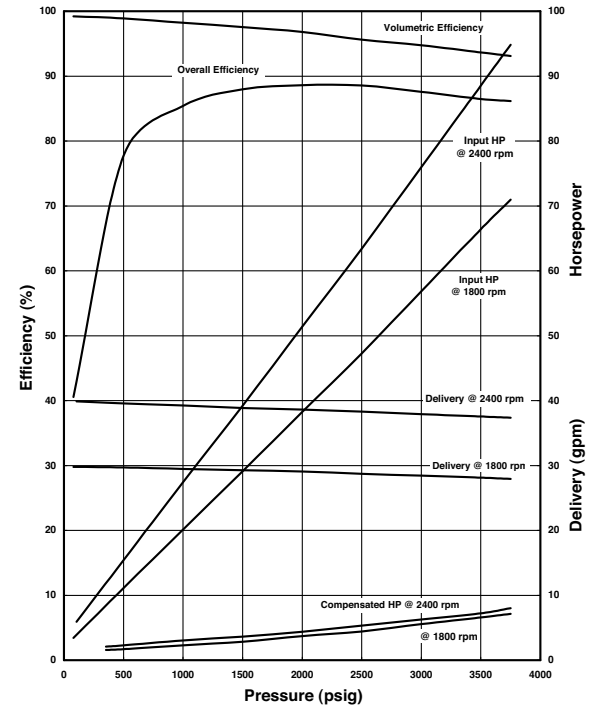

Oilgear Performance Curves

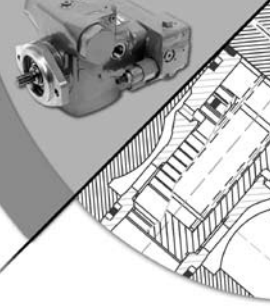

Performance curves are based on a viscosity of 160 SSU.

■ PVM-075

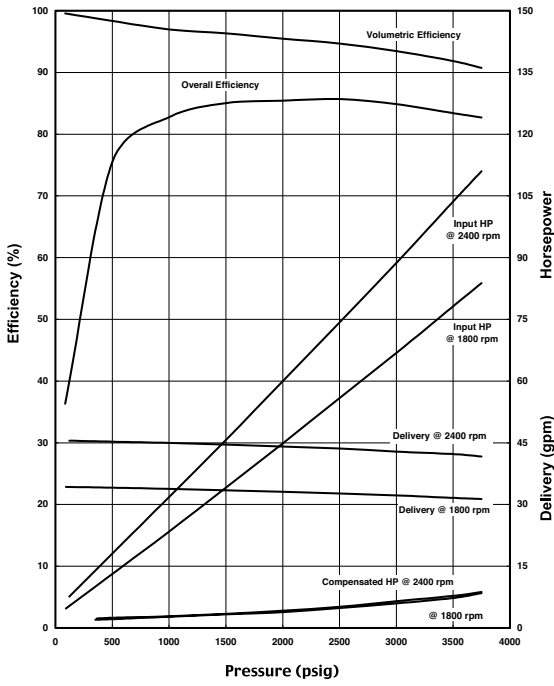

■ PVM-076

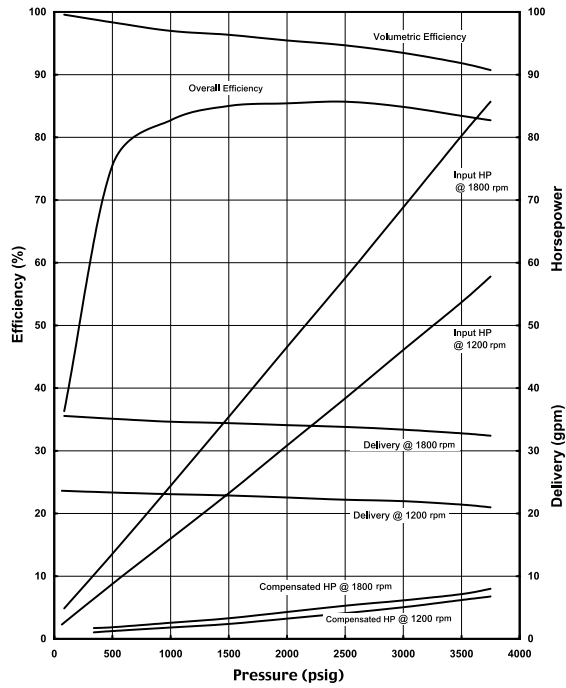

■ PVM-098

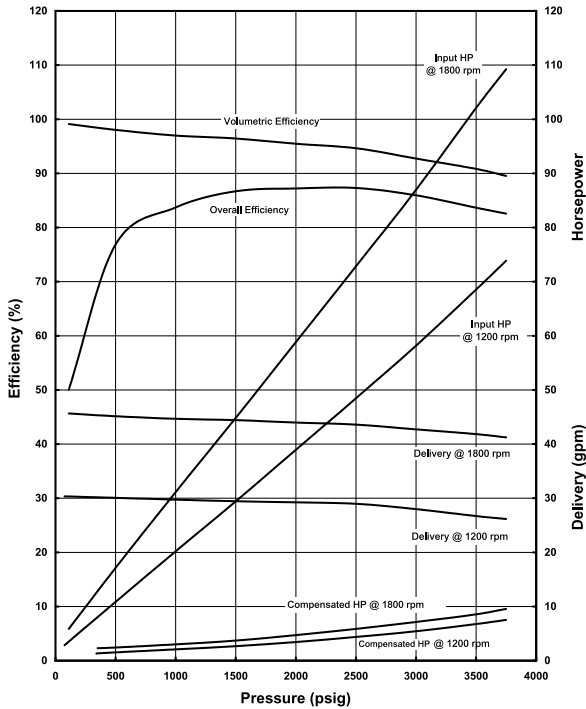

■ PVM-130

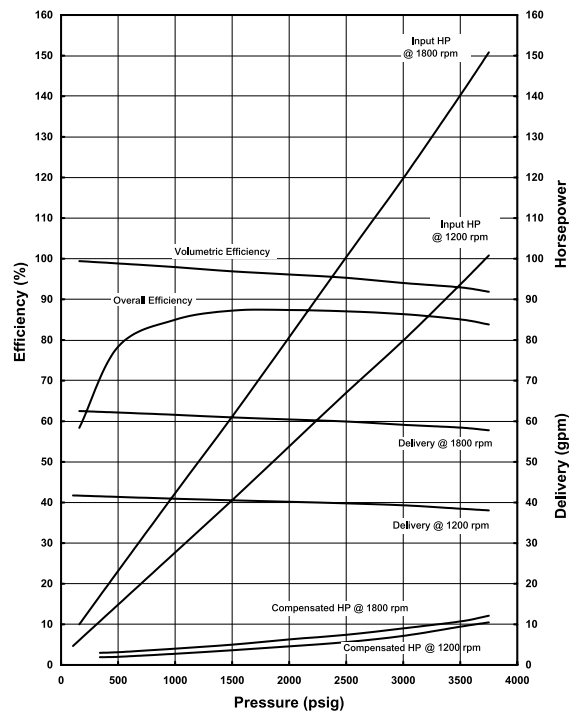

Oilgear Performance Curves

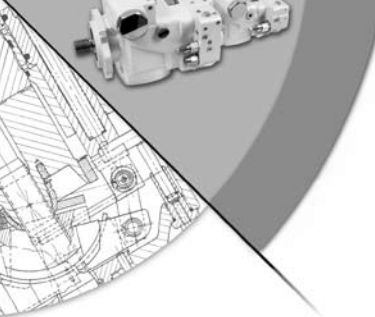

SOUND

Sound curves are based on a viscosity of 500 SSU.

■ PVM-011

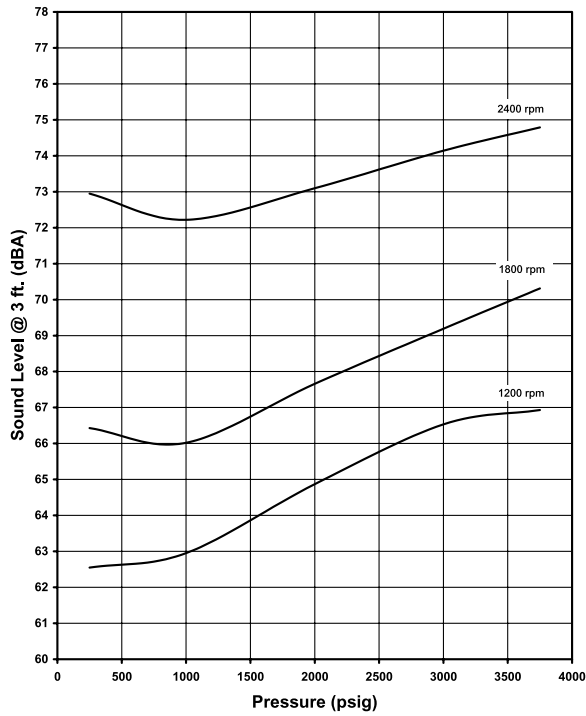

■ PVM-014

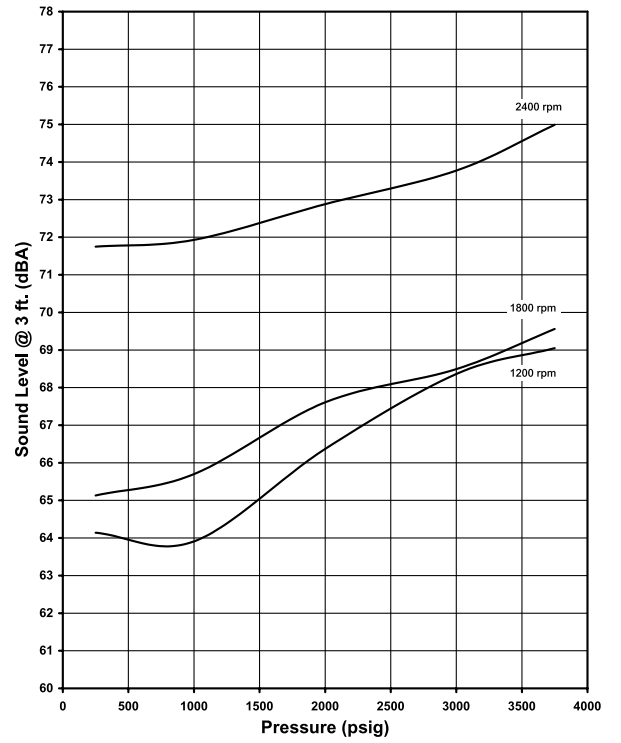

■ PVM-022

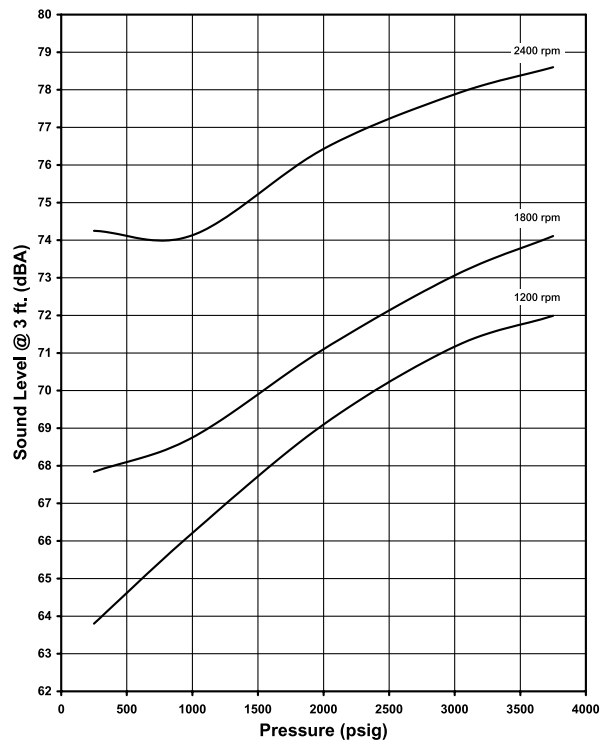

■ PVM-025

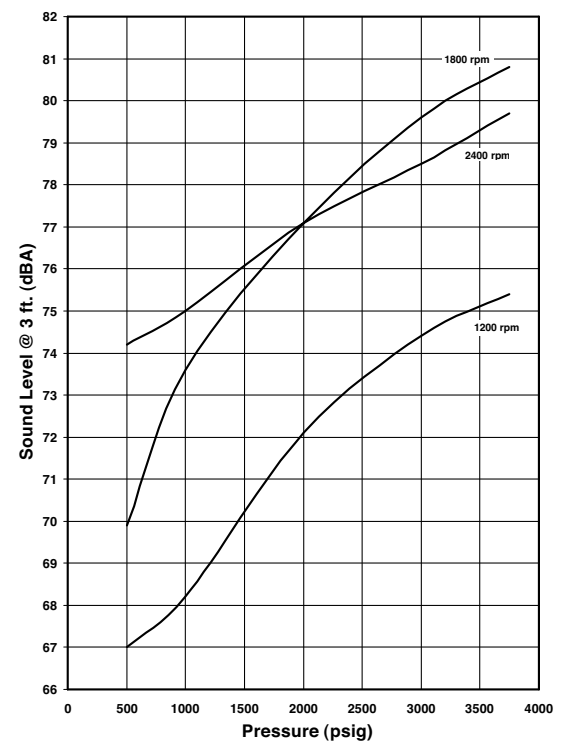

* Be sure system and pumps are protected against overloads with a high-pressure relief valve.

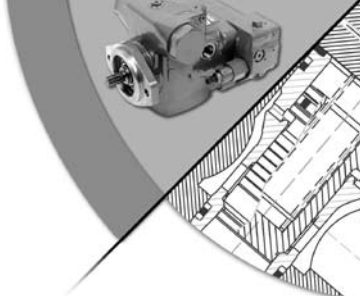

Sound curves are based on a viscosity of 500 SSU.

PVM-034

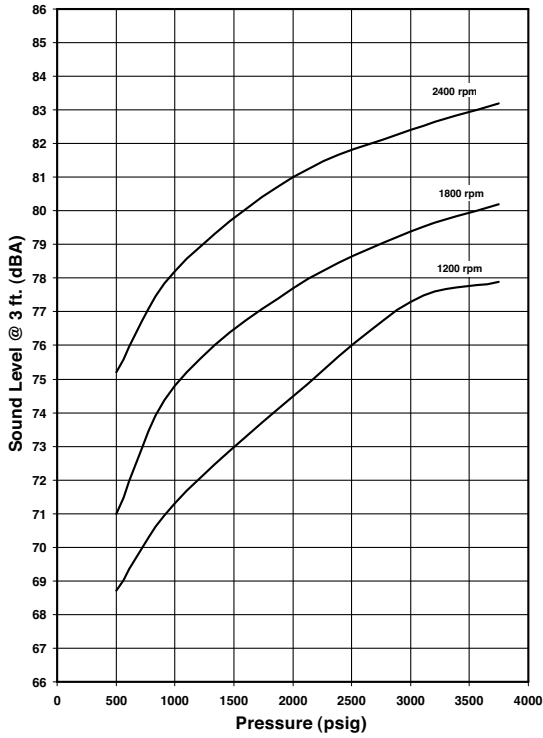

PVM-046

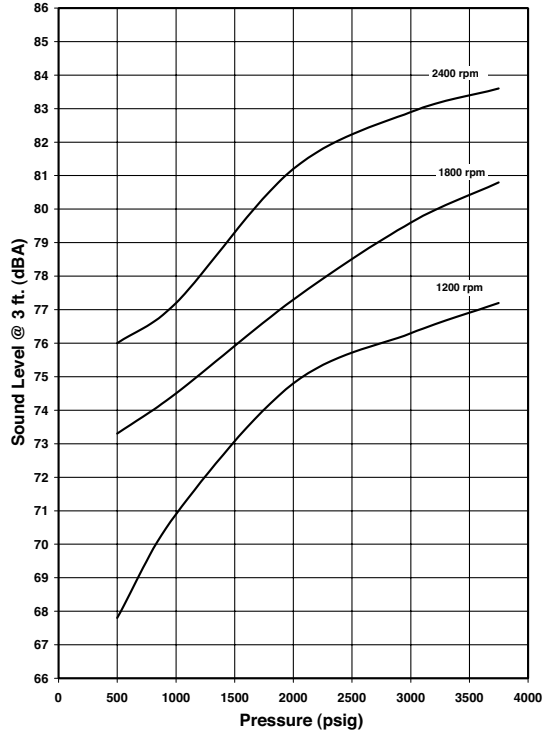

PVM-064

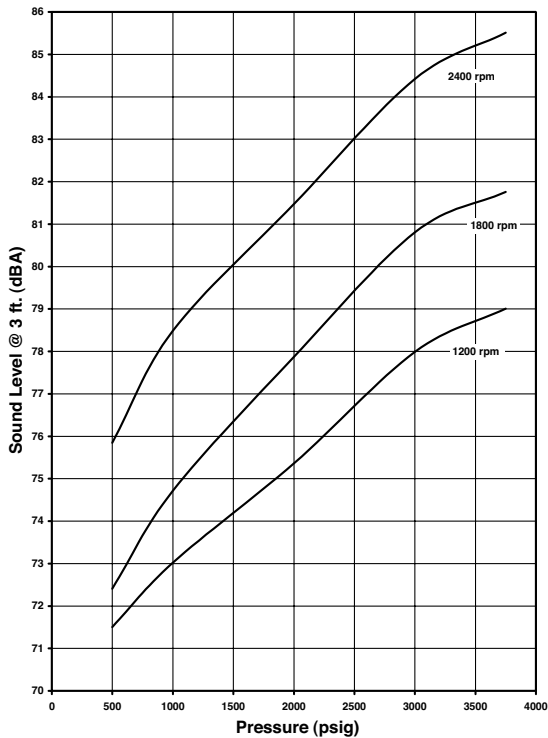

PVM-065

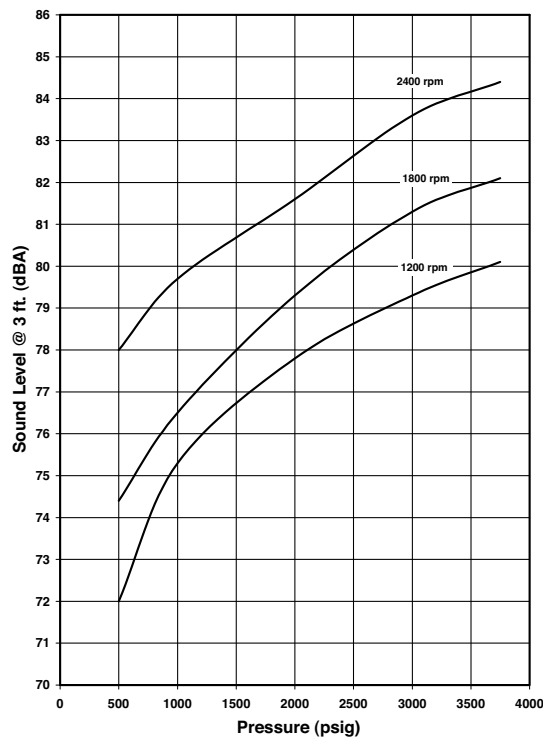

Oilgear Sound Curves

* Be sure system and pumps are protected against overloads with a high-pressure relief valve.

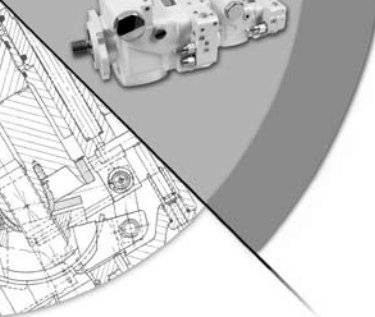

Sound curves are based on a viscosity of 500 SSU.

PVM-075

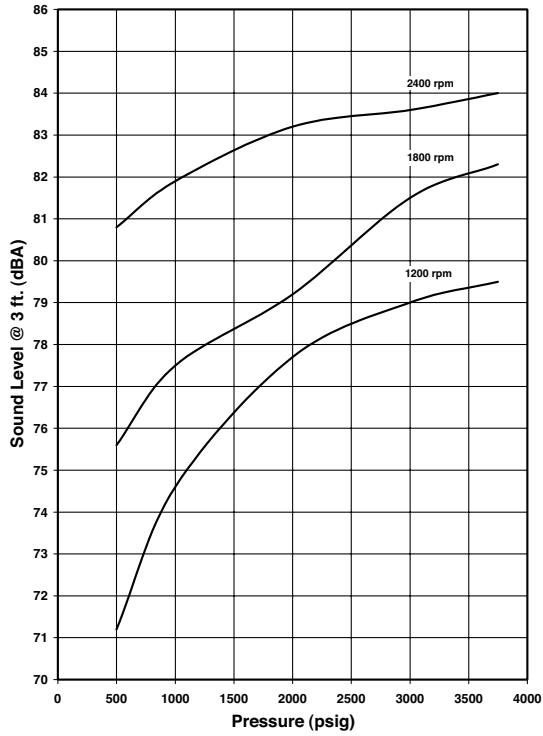

PVM-076

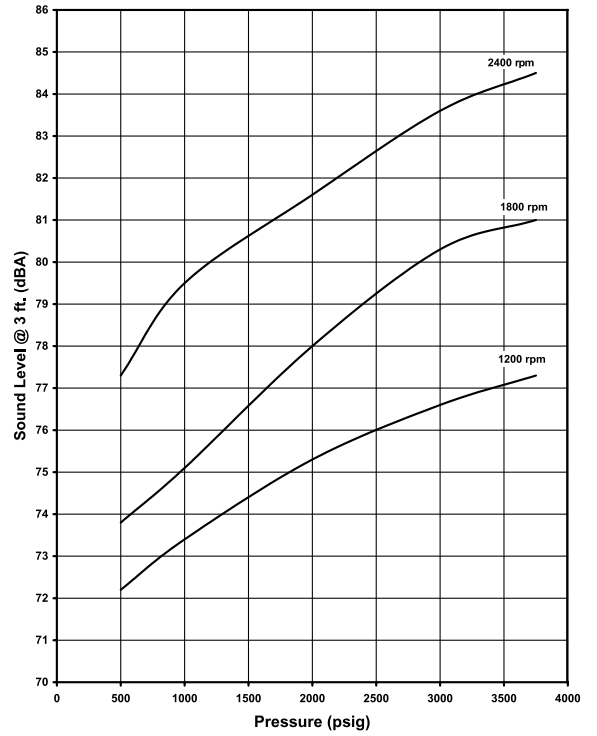

PVM-098

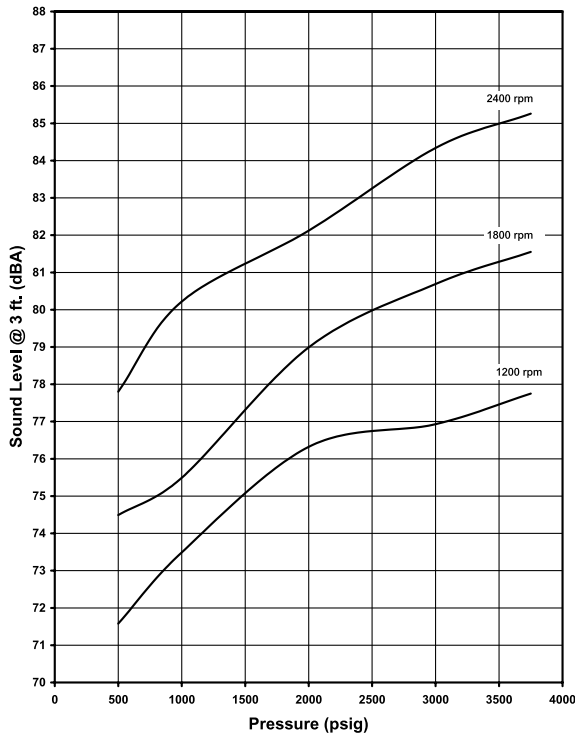

PVM-130

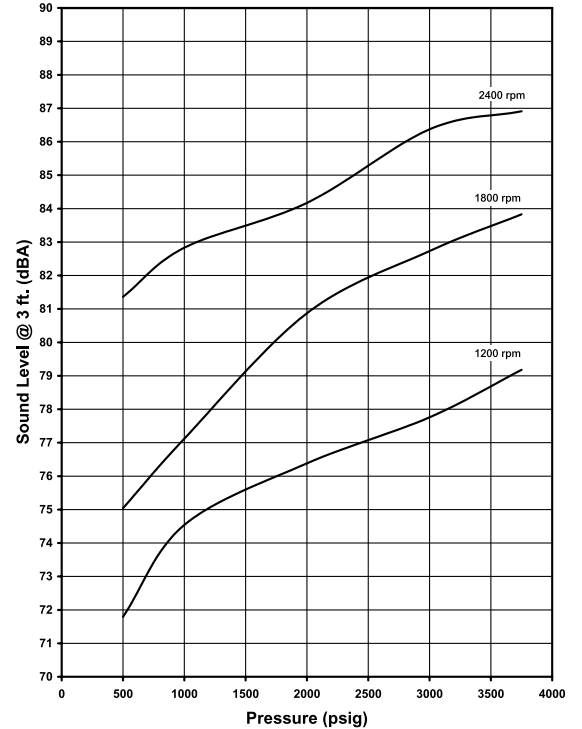

* Be sure system and pumps are protected against overloads with a high-pressure relief valve.

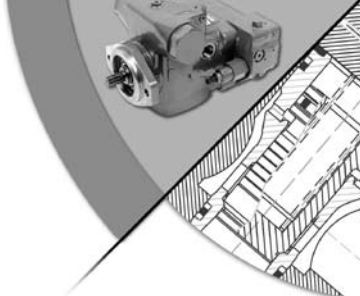

INLET SUCTION/SUPERCHARGE

Inlet/supercharge curves are based on a viscosity of 160 SSU.

■ PVM-011

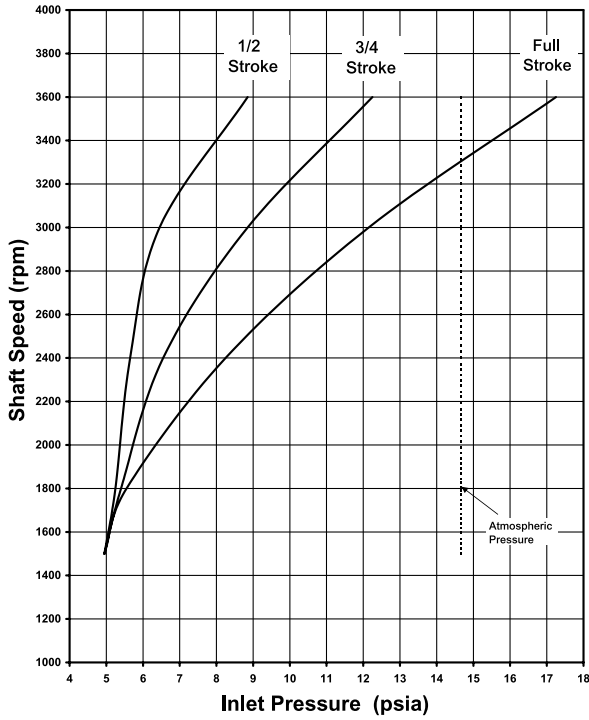

■ PVM-011

Max % Stroke @ Flooded Inlet

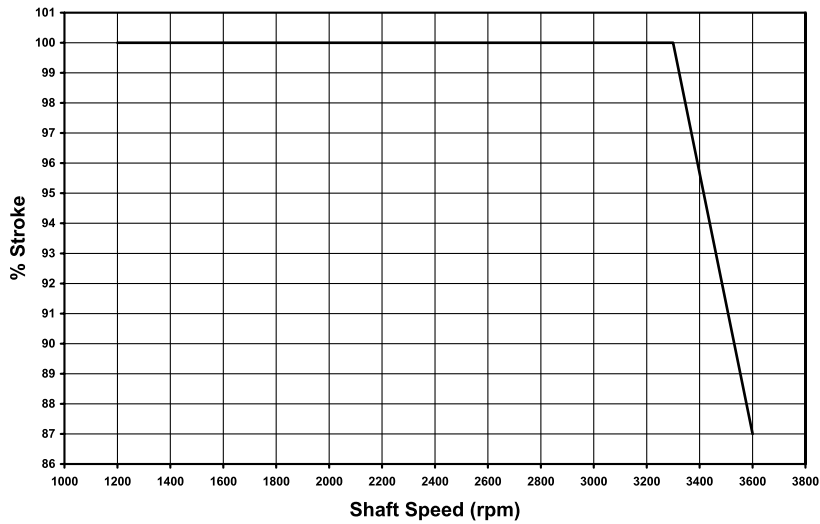

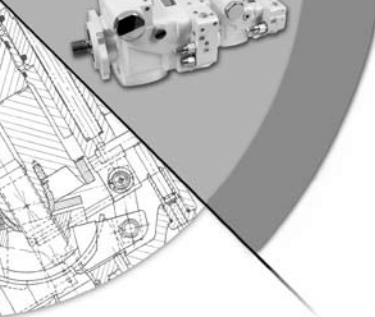

PVM-014

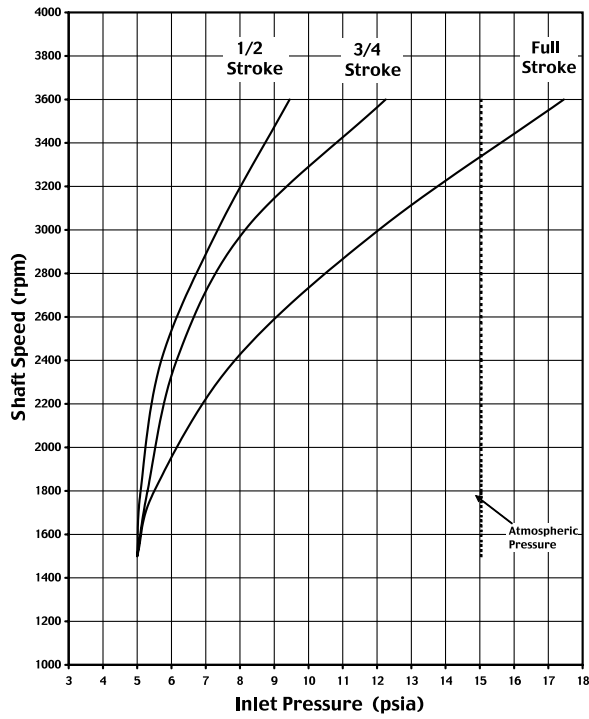

PVM-014

Max % Stroke @ Flooded Inlet

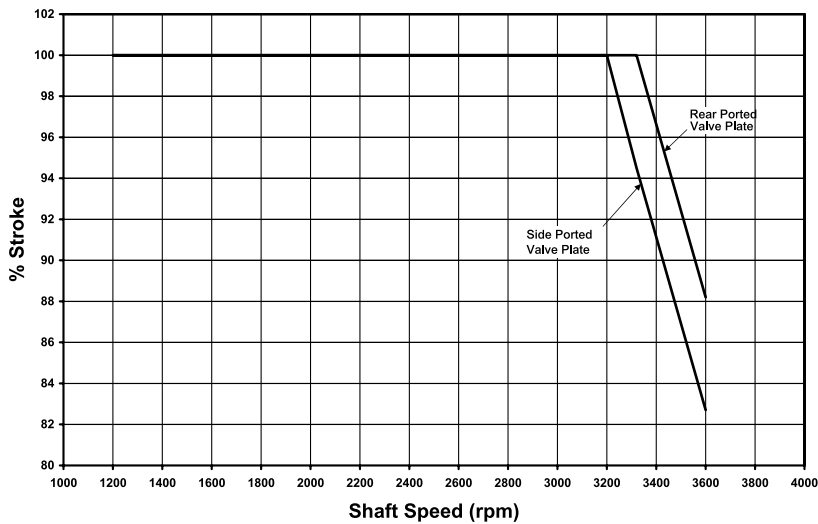

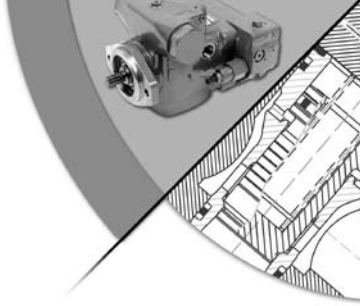

PVM-022

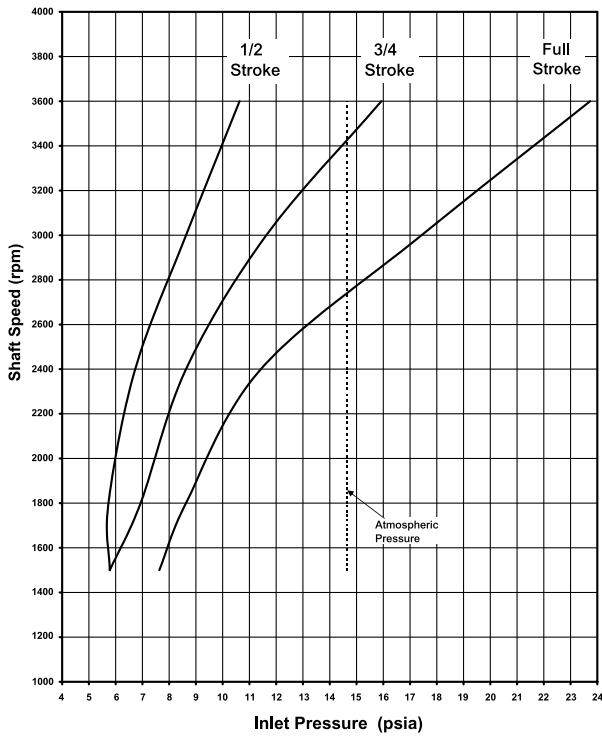

PVM-022

Max % Stroke @ Flooded Inlet

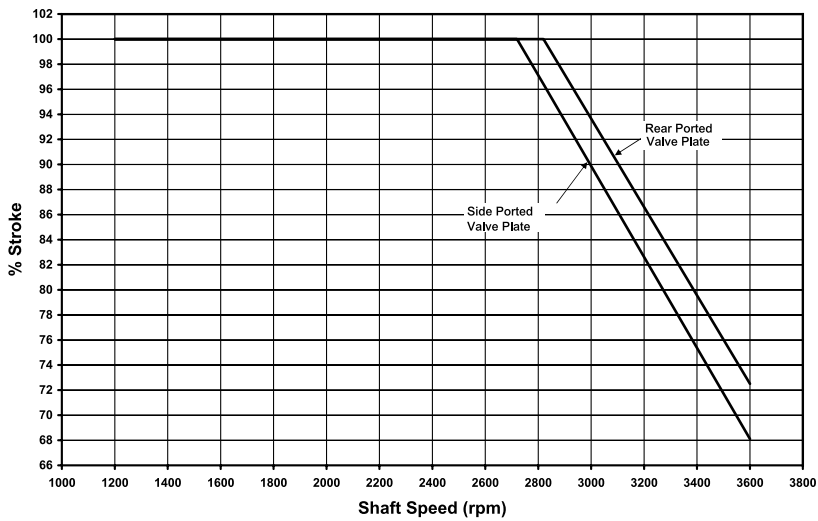

Oilgear Inlet/Suction Curves

Oilgear Inlet/Suction Curves

■ PVM-025

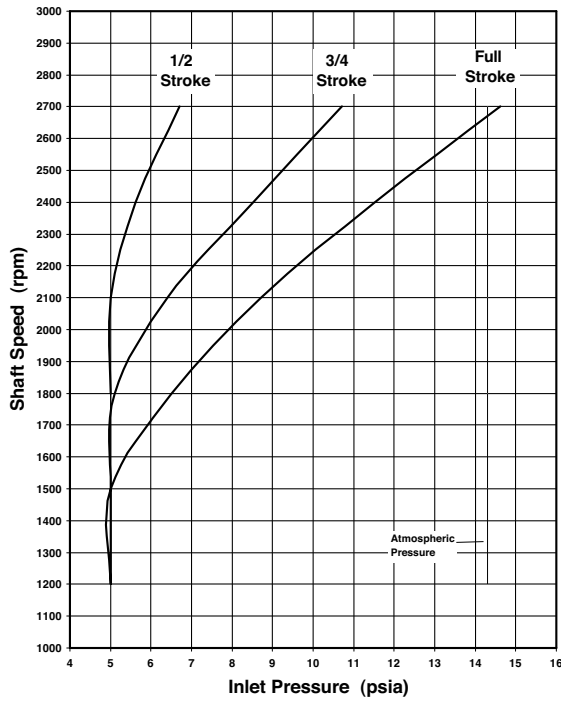

■ PVM-034

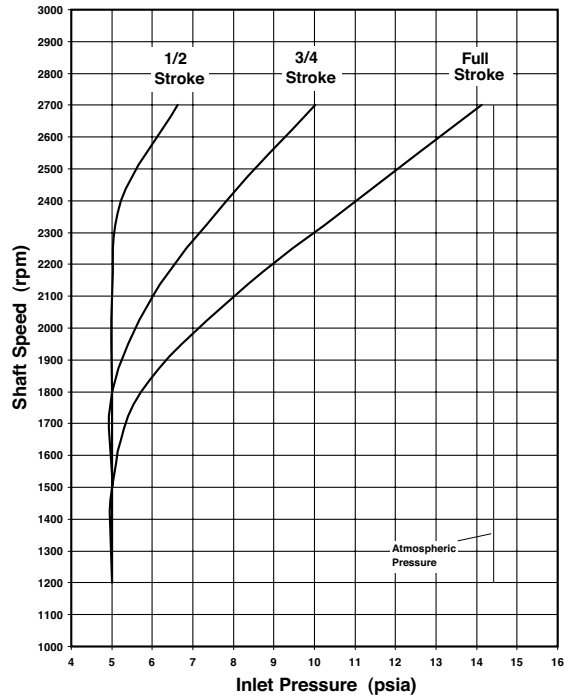

■ PVM-046

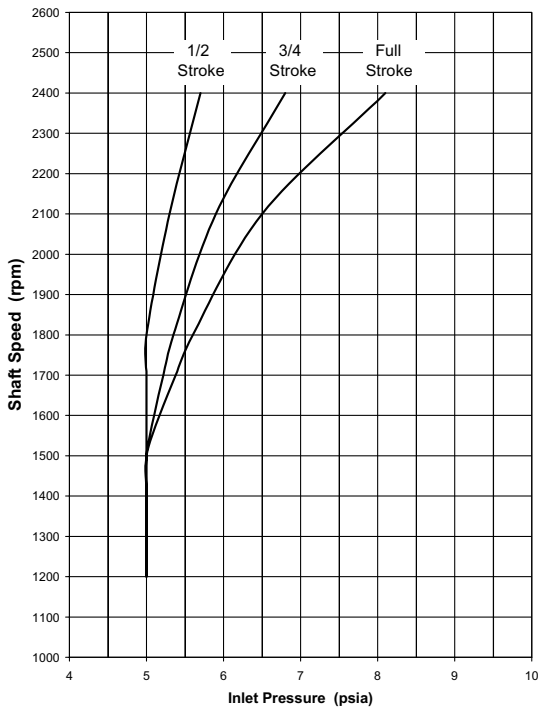

■ PVM-064

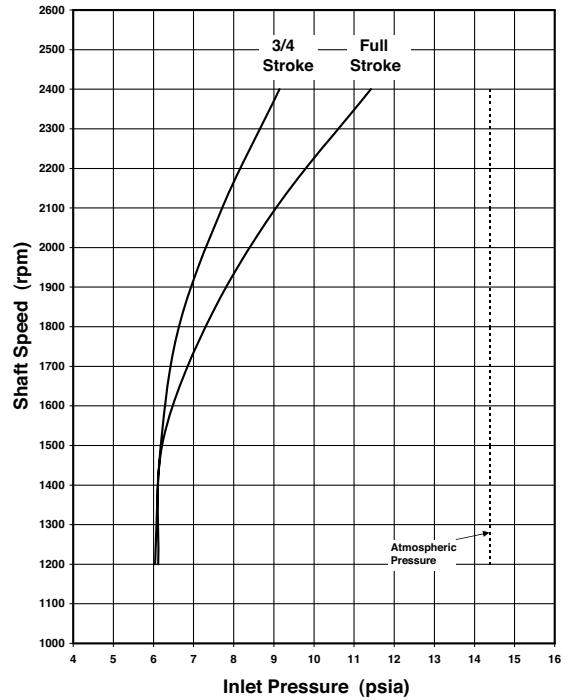

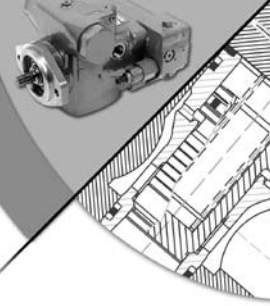

Oilgear Inlet/Suction Curves

PVM-065

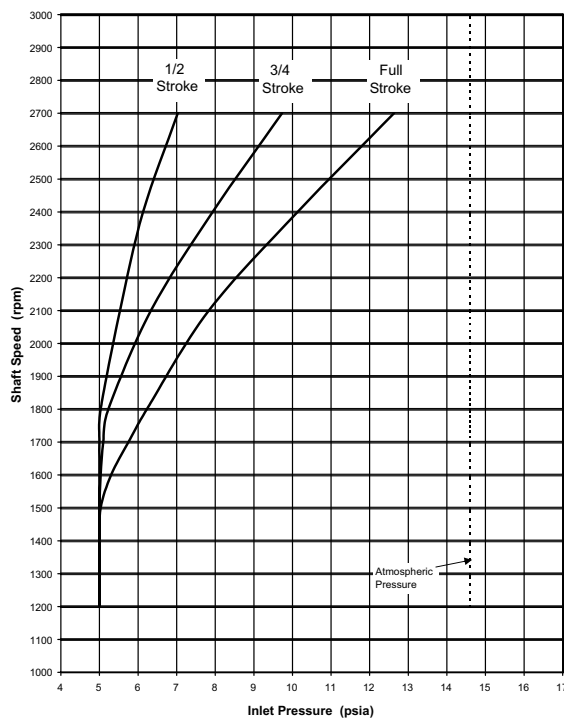

PVM-075

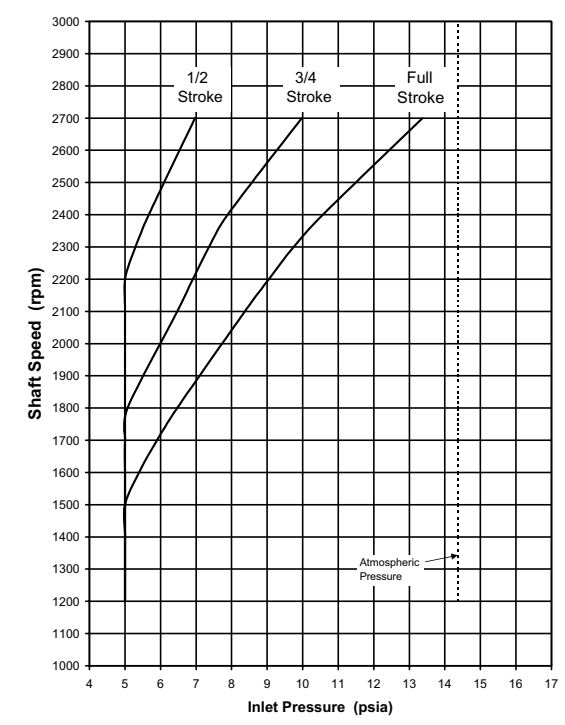

PVM-076

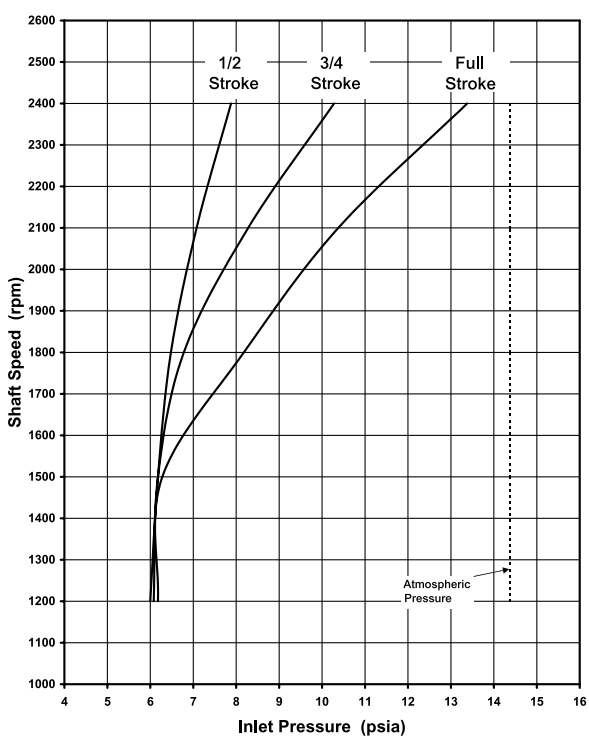

PVM-098

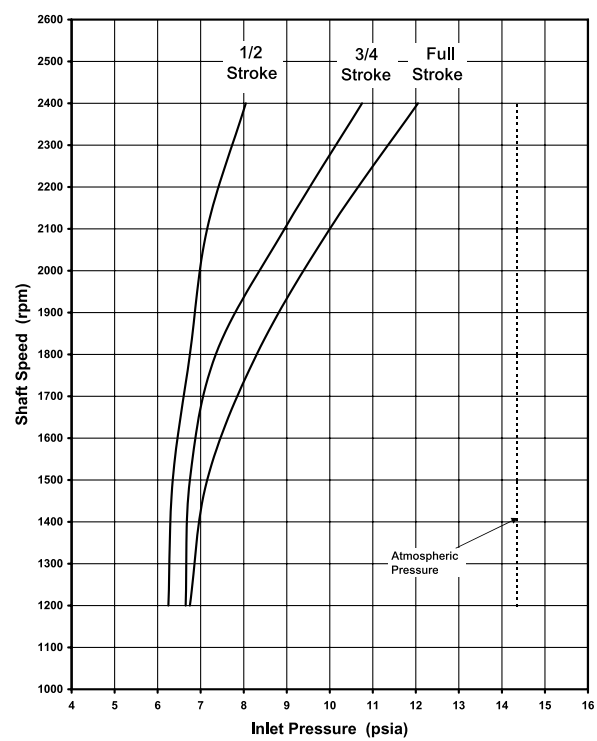

PVM-130

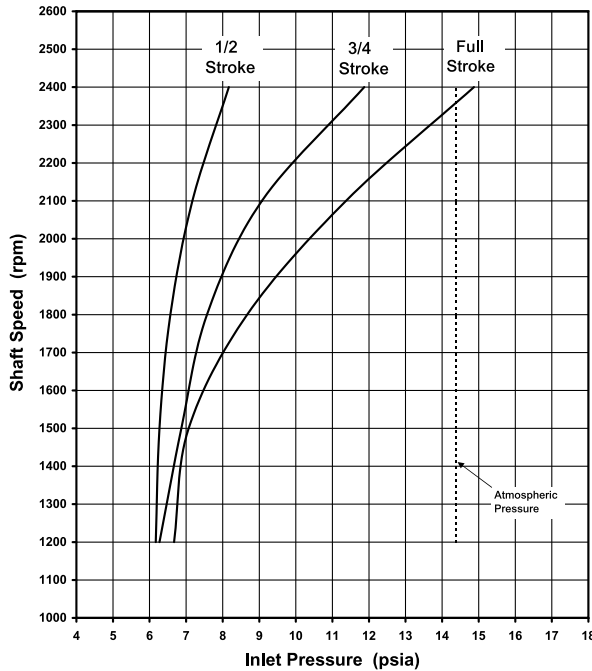

MULTIPLE PUMP COMBINATIONS

Two or more Oilgear “PVM” axial piston variable delivery pumps can be integrally coupled together and driven from a single shaft. In most cases (see Specifications) both pumps can be used at full rated output. Pump deliveries can be combined for large volume circuits or deliveries can be used individually. See the following table and calculations for Allowable Thru-shaft Torque.

How to calculate torque for each pump

$$T \text{ (in. lbs.)} = \frac{\text{Pressure (psi)} \times \text{Displacement (cu. in./rev.)}^*}{5.625}$$

Add the respective torques for each unit:

T1 = front pump torque required

T2 = second pump torque required

Tn = Additional pump or torque for any other driven device

T1 + T2 + Tn Sum must be less than T max. shown in table



Unit Size	Input Shaft Code	Max Input Shaft Torque (in-lbs)	Max Torque on Rear Pump Drive Shaft
011, 014 & 022	All	1290	915
025, 034 & 046	All	2250	1820
065 & 075	Y or S	3500	3060
	B	6400	
	C	7000	
064, 076, 098 & 130	B or Y	6400	5250
	S	7000	
	C	10500	

* Assumes 90% mechanical efficiency.

HOW TO ORDER

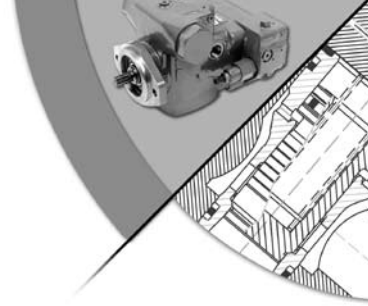

BLOCK NUMBER EXPLANATION	1	2	3	-	4	-	5	6	7	-	8	9	10
VARIABLE PUMP EXAMPLE	P	V	M	-	011	-	B1	U	B	-	L	D	A

Continued from above

BLOCK NUMBER EXPLANATION	11	-	12	-	13a	13b	13c	13d	14	-	15	-	16	-	17
VARIABLE PUMP EXAMPLE	B	-	P	-	1	N	N	/J	SN	-	AN	-	05	-	XXX

- 1 = UNIT
P = Pump
- 2 = TYPE
V = Variable
- 3 = DESIGN TYPE
M = Pump Series
- 4 = UNIT SIZE

011 = 10.8 cc/rev (0.66 cipr)	A Frame
014 = 14.1 cc/rev (0.86 cipr)	
022 = 22.1 cc/rev (1.35 cipr)	
025 = 25.4 cc/rev (1.55 cipr)	B Frame
034 = 33.8 cc/rev (2.06 cipr)	
046 = 46.4 cc/rev (2.83 cipr)	
065 = 65.5 cc/rev (4.00 cipr)	
075 = 75.5 cc/rev (4.61 cipr)	C Frame
064 = 63.6 cc/rev (3.88 cipr)	
076 = 76.5 cc/rev (4.67 cipr)	
098 = 98.3 cc/rev (6.00 cipr)	
130 = 130.2 cc/rev (7.94 cipr)	
- 5 = DESIGN SERIES
B1 = A Frame
A1 = B Frame
A2 = C Frame
- 6 = SAE DESIGN SERIES MODIFIER
U = SAE Connector & Mounting
- 7 = SEALS
B = Nitrile (standard)
V = Viton
P = EPDM w/PTFE shaft seal
- 8 = ROTATION
L = Left-hand (CCW)
R = Right-hand (CW)
- 9 = VALVE PLATE TYPE
S = Rear Ported
G = Side Ported
D = Thru-Shaft w/ Side-Ports
- 10 = CONNECTION TYPE
A = SAE Straight Port
F = SAE Flange (B or C frame)

- 11 = SHAFT TYPE
See Shaft Table Below.
- 12 = PRESSURE CONTROL
P = Pressure Compensator
- 13a = PRESSURE COMPENSATOR OPTIONS
1 = Single Pressure Compensator Setting
A = Proportional EH Control
B = Inverse Proportional EH Control
C = Pressure Compensator w/Normally Open Soft Start
K = Pressure Compensator w/Normally Closed Soft Start
- 13b = SOLENOID VOLTAGE
N for Pressure Compensator
For EH Controls:
2 = 12 VDC
3 = 24 VDC
For Soft Start Controls:
0 = 115 VAC
2 = 12 VDC
3 = 24 VDC
- 13c = CONNECTOR
N for Pressure Compensator
For EH & Soft Start Controls:
N = No Connector
R = DIN (1/2" NPT w/o Lite)
S = DIN (PG-11 w/o Lite)
*6 = DIN Connector Amplifier
* Available for EH Control Only

- 13d = CONTROL MODIFIER
Blank for Pressure Compensator & EH Control
/F = Standard Load Sense
/J = Adjustable Load Sense **
/B = Adjustable Load Sense w/ Bleed-off **
** Consult factory for use with EH Control, not available with Soft Start Control
- 14 = STROKE LIMITER OPTION
NN = None
SN = Adjustable Max. Volume Stop
- 15 = AUXILIARY ADAPTERS (for thru-shaft)
Blank = None (for all rear and side port, non thru-shaft units)
CP = Cover Plate
AA = SAE A-A Adapter & Coupling (A frame only)
AN = SAE A Adapter & Coupling
BN = SAE B Adapter & Coupling (B or C frame only)
CN = SAE C Adapter & Coupling (C frame only)
NN = No Adapter or Coupling
- 16 = GEAR PUMPS
Blank = None
05 = 0.488 cipr
07 = 0.672 cipr
10 = 0.976 cipr
14 = 1.403 cipr
20 = 2.015 cipr
- 17 = SPECIAL PUMP MODIFIER
(Assigned by factory when necessary)

Shaft Table

Shaft Code	PVM-011/ -014/-022	PVM-025/ -034/-046	PVM-065/ -075	PVM-064/-076/ -098/-130
Y	.75" Keyed	.875" Keyed	1.00" Keyed	1.25" Keyed
B	.875" Keyed	1.00" Keyed	1.25" Keyed	1.50" Keyed
S	SAE A Spline	SAE B Spline	SAE B Spline	SAE C Spline
C	SAE B Spline	SAE B-B Spline	SAE B-B Spline	SAE C-C Spline
D	None	None	SAE B-B Spline Cl 5	SAE C-C Spline Cl 5
L	None	None	SAE B Spline Cl 5	None

Shaft Note:

Spline Shafts S and C should be used for rigid internal drives such as gear boxes and internally splined electric motors. Spline Shafts D and L should be used for clamped and slip fit flexible couplings. Mating internal splines for all shafts is per ANSI B92.1 tolerance class 5.

Oilgear How to Order

Oilgear

