

Two-electrode conductivity sensor for the continuous measurement in water/steam cycle applications.

Swansensor UP-Con1000

Conductivity sensor with stainless steel body, titanium electrode and built-in temperature probe for automatic temperature compensation.

Specifications

Recommended measuring range:
0.055 $\mu\text{S}/\text{cm}$ to 30 mS/cm
Accuracy (at 25°C): $\pm 1\%$
Measuring range and accuracy with
AMI Powercon

Cell constant: $\sim 0.04 \text{ cm}^{-1}$
Indicated on sensor with 5 decimal places.

Temperature sensor type:
Pt1000, DIN class A

Operating conditions:
- Continuous temperature: 100 °C at 6.5 bar
- Max. temperature: 120 °C at 6.5 bar
- Pressure: max. 30 bar at 25 °C

Materials in contact with sample:
- Shaft: Stainless steel SS 316L
- Electrode: Titanium
- Isolation: PEEK

Process connection & sensor mounting:
- SWAN slot-lock (patent pending) for quick sensor release in suitable flow cells
- or NPT 3/4"

Electrical connection:
- M16 plug (protection degree IP67)
- or directly attached cable with end sleeves

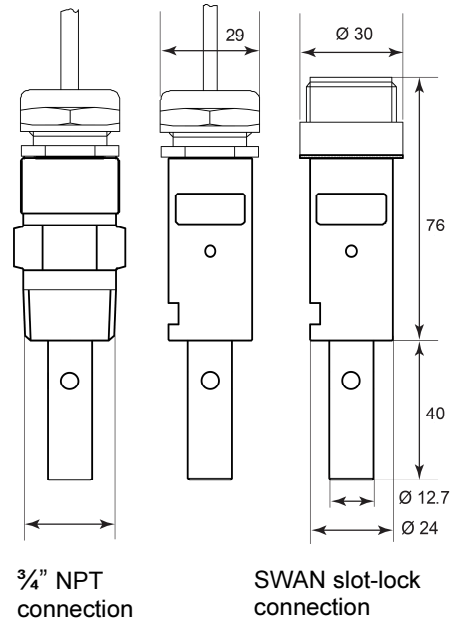

Limits for temperature and pressure (values in the hatched area are allowed for short time periods):

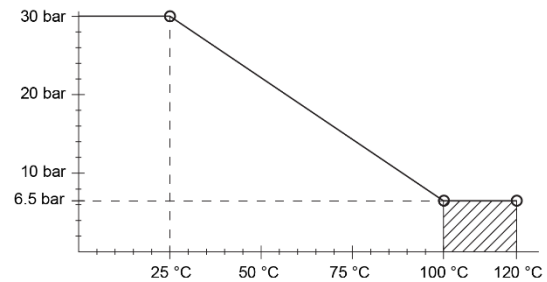

Order scheme	Swansensor UP-Con1000	A – 87 . 334 .		
Process connection	NPT 3/4"	1		
	SWAN slot-lock	2		
Electrical connection	M16 plug		0	0
	1 m cable with end sleeves		1	0
	5 m cable with end sleeves		5	0
	15 m cable with end sleeves		7	0

Cables for sensors with M16 plug (A-87.334.100 and A-87.334.200):
A-88.155.X20 Cable with M16 connector and end sleeves, available in lengths of 1 m, 5 m, 15 m or 25 m