

Flow divider with independent phase correction and anticavitation valves for each element

Codice:

9RV NN M CC

9RV	Flow Divider Typology
NN	Number of elements
M	Code of setting range of the valves
CC	Displacement Code

TABELLA "M"	
A	10÷ 105 bar
B	70÷ 210 bar
C	140÷ 350 bar

Example: Flow divider with two elements (same displacement): :
RV-2V / 11 x 2 with valve 10 ÷ 105 bar

9RV 02 A 47

Example: Flow Divider with 4 elements with different displacement (max 7):
RV-2V / 9+14+14+22 with valve 70 ÷ 210 bar

9RV 04 B 45 49 49 55

NOTE: to define codes for flow dividers with more than 7 different displacement, please contact our sales department.

Table: 1

Displacem. Cm ³ /rev	CC Code	Max Pressure bar	One element flow rate l/min		
			MIN	RECOMMENDED	MAX
4	41	210	4,8	7,6	10
6	43	210	7,2	10,8	15
9	45	210	10,8	15,1	22,5
11	47	210	13,2	19,4	27,5
14	49	200	16,8	25,9	35
17	51	200	20,4	30,2	42,5
19	53	190	22,8	34,6	47,5
22	55	180	26,4	41	55
26	57	160	31,2	45,4	65
30	59	160	36	54	75
34	61	140	40,8	61,6	85
40	63	130	48	71,3	100

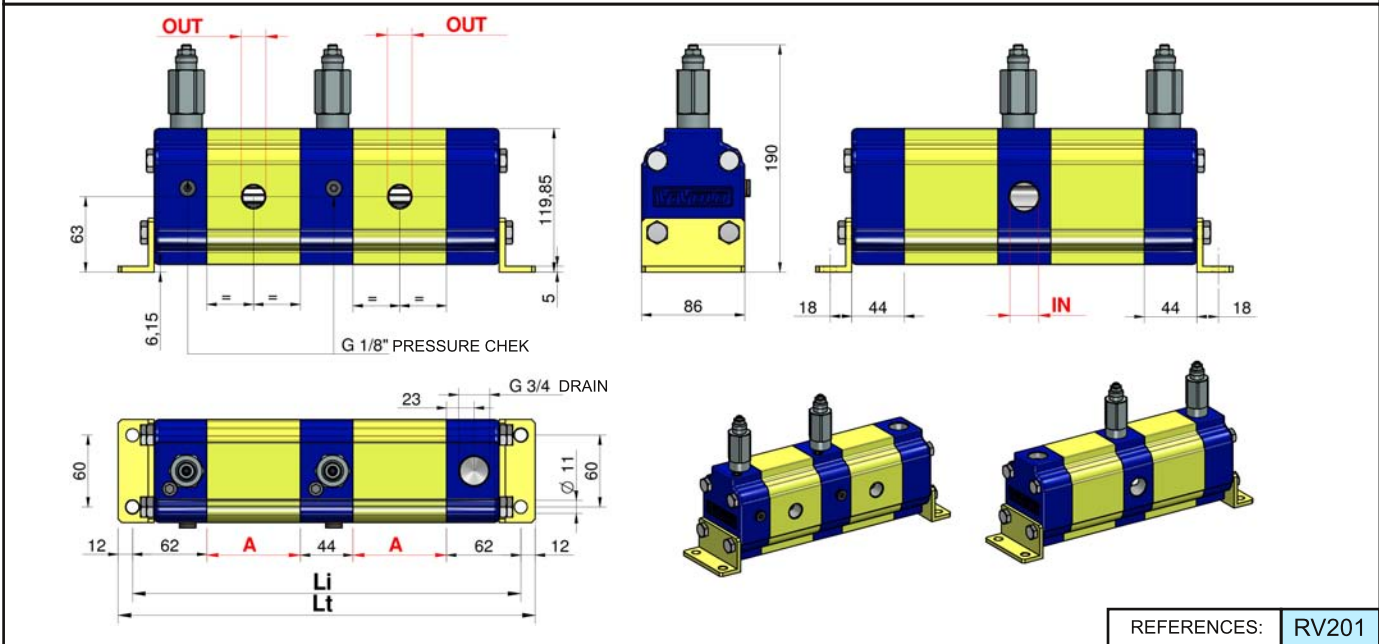

Table: 2

Li = Distance between fixing hole centres (single displacement flow divider)

Cm ³ /rev	A	IN	OUT	Number of elements														
				2	3	4	5	6	7	8	9	10	11	12	13	14	15	16
4	47	3/4 BSP	1/2 BSP	262	353	444	535	626	717	808	899	990	1081	1172	1263	1354	1445	1536
6	50	3/4 BSP	1/2 BSP	268	362	456	550	644	738	832	926	1020	1114	1208	1302	1396	1490	1584
9	54	3/4 BSP	1/2 BSP	276	374	472	570	668	766	864	962	1060	1158	1256	1354	1452	1550	1648
11	58	3/4 BSP	1/2 BSP	284	386	488	590	692	794	896	998	1100	1202	1304	1406	1508	1610	1712
14	64	3/4 BSP	1/2 BSP	296	404	512	620	728	836	944	1052	1160	1268	1376	1484	1592	1700	1808
17	68	3/4 BSP	1/2 BSP	304	416	528	640	752	864	976	1088	1200	1312	1424	1536	1648	1760	1872
19	72	3/4 BSP	1/2 BSP	312	428	544	660	776	892	1008	1124	1240	1356	1472	1588	1704	1820	1936
22	78	3/4 BSP	1/2 BSP	324	446	568	690	812	934	1056	1178	1300	1422	1544	1666	1788	1910	2032
26	82	1 BSP	3/4 BSP	332	458	584	710	836	962	1088	1214	1340	1466	1592	1718	1844	1970	2096
30	90	1 BSP	3/4 BSP	348	482	616	750	884	1018	1152	1286	1420	1554	1688	1822	1956	2090	2224
34	97	1 BSP	3/4 BSP	362	503	644	785	926	1067	1208	1349	1490	1631	1772	1913	2054	2195	2336
40	106	1 BSP	3/4 BSP	380	530	680	830	980	1130	1280	1430	1580	1730	1880	2030	2180	2330	2480

Table: 3 in this table the number of inlets in function of the number of elements are indicated.

Number of elements	2	3	4	5	6	7	8	9	10	11	12	13	14	15	16
"IN" Number of inlets	1	1	2	2	3	3	4	4	5	5	6	6	7	7	8

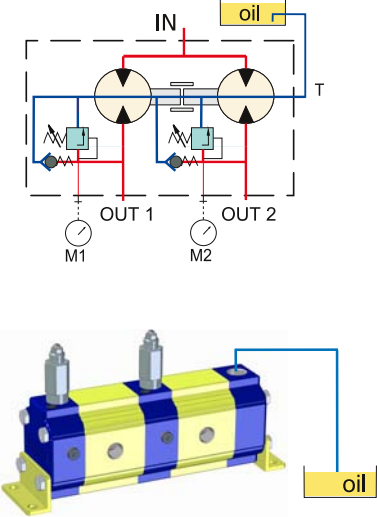
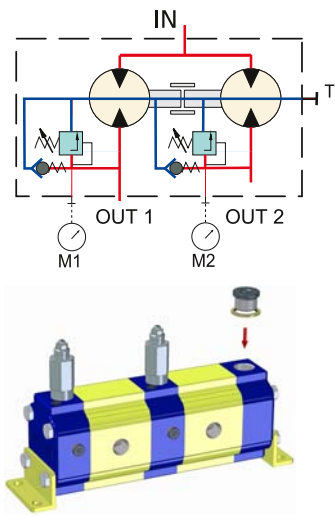
EXTERNAL DRAIN <i>STANDARD SETUP</i>	INTERNAL DRAIN
<p>For the correct functioning of the flow divider, it has to be installed <i>under the oil level</i>. The drain tube has to pick up under the oil level and it has not to aspire air.</p>	<p>To predispose the divider to the internal drain, plug the 3/4" G drain port (T)</p> <p>Note: with this configuration the function of anticavitation valves is annulled</p>
	

In **table 1** the functioning range of single flow divider elements is indicated.

The higher is the feeding capacity (q), the higher is the precision of flow division, but in opposition there are losses of loading and higher noise. Therefore we suggest to feed the elements with capacities equal or a few superior to the ones indicated in the column "**RECOMMENDED**".

It's important remember to verify the capacities even in phase of flow reunion.

The pressures indicated are to be considered as maximum of functioning, the flow divider is able to bear peaks of pressure 20% superior.

How to calculate the "Li" and "Lt" measures of flow dividers:

From **table 2** it is possible to obtain the "Li" measure for flow dividers up to 16 elements with equal displacements; for flow dividers with different elements or with more than 16 elements the "Li" and "Lt" measure have to be calculated by the following formula:

$$Li = [(n-1) \times 44] + 124 + (A1 + A2 + A3 + \dots)$$

$$124 = 62 + 62$$

n = Number of elements of flow divider

A1... An = heights of elements of flow divider

$$Lt = Li + 24$$

$$24 = 12 + 12$$

EXAMPLE: To obtain the measures **Li** and **Lt** of a flow divider with three elements (n=3), **RV-2V 19 + 11 + 9**

Distance between fixing hole centres

$$Li = [(3-1) \times 44] + 124 + 72 + 58 + 54 = 396 \text{ mm}$$

Total Length

$$Lt = 396 + 24 = 420 \text{ mm}$$

In **table 3** the number of inlets in fuction of the number of elements are indicated.

For flow dividers with many inlets, as they are all communicating it is even possible to use only one of them, by plugging the other ones. We suggest to use at least one **3/4" BSP** inlet every **80 l/min** capacity and at least one **1" BSP** inlet every **120 l/min** capacity

To obtain errors of division inferior to 3% there must be no difference of pressure between the elements superior to 30 bar. To obtain high precisions the respect of the following parametres is also important:

- Environment temperature: -10°C ÷ +60°C Oil temperature: +30°C ÷ +60°C
- Hydraulic oil based on hlp, hv (din 51524) minerals Oil Viscosity 20 ÷ 40 cSt
- Oil filtering 10 ÷ 25 µ