



## SYSTEMS M4500

## INDUSTRIAL CONTROLLER

### S4520-RDC: MOTION CONTROL CO-CPU With RESOLVER FEEDBACK

- Intelligent I/O board with motion control I/O and built-in M4500 processor (same as M4500 PLC section)
- Resolver servo feedback interface: 12-bit (0-4095) resolver-to-digital converter
- Two +/-10V bipolar 12-bit analog outputs
- One +/-10V absolute value 10-bit analog input
- Two 10-30VDC digital interrupt inputs
- Servo amplifier I/O: enable output (TTL), HALL sensor emulation outputs (TTL), amplifier fault input (TTL)
- Programmed with SYSdev
- Interfaces to laptops via RS-232 for program download and on-line monitoring
- Removable field wiring connectors
- Can be installed in any M4510 I/O slot
- Compatible with M4510 and M4512 only
- Occupies one I/O slot

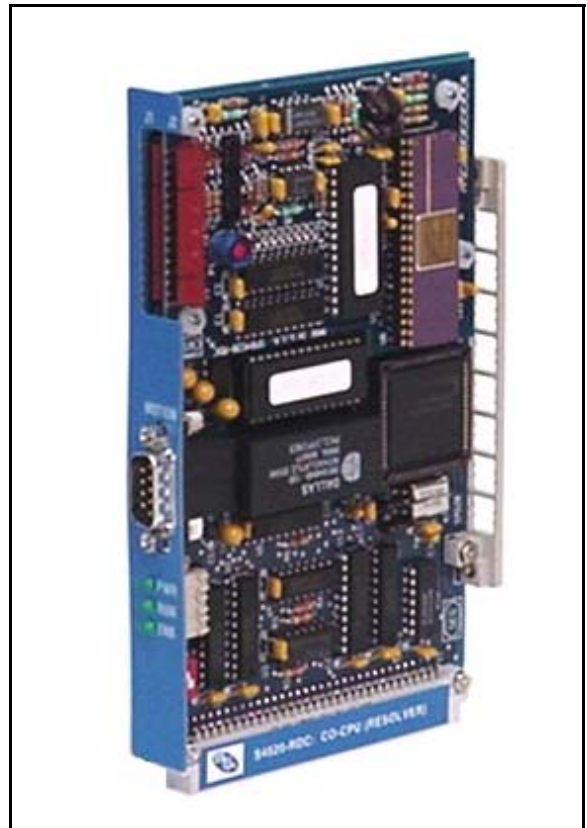

### General Description

The S4520-RDC is an intelligent I/O board (CO-CPU) primarily designed for use in motion control applications. Designed for servo motion control, the S4520-RDC is used to implement a servo axis in either single or multi-axis control applications (where multiple S4520 would be used - one for each axis). The board derives a main reference position to be followed directly from the back-plane of an M4510 or M4512 it is mounted in, interfaces with a brushless servo amplifier which drives the servo

motor, and monitors the actual servo position via resolver feedback from the servo motor. The user written application program can then execute a PID algorithm to “close” the loop, allowing the servo axis to accurately track the primary position reference. Note that the S4520-RDC is designed to interface with servo motors equipped with resolvers for position feedback, not encoders. For applications with servo motors equipped with encoders for feedback, see the S4520-ENC data sheet.

## General Description (cont'd)

The S4520-RDC contains its own independent processor and application specific I/O designed for motion control. The processor architecture of the S4520-RDC is identical to the M4500 processor utilizing the same MCS-96 microcontroller. This processor is programmed with SYSdev, which allows the user program to be written in any combination of Ladder, High-level (C), or MCS-96 Assembly. The processor section contains 32K bytes of battery-backed CMOS RAM user program memory and 8K bytes data memory.

The scan time of the processor section is 0.25msec per 1K bytes typical with through-puts as low as 80 microseconds. The S4520-RDC is equipped with a stan-

dard DB9 RS-232 connector which allows the user program and data to be directly downloaded from a laptop running SYSdev. The S4520-RDC communicates to the main M4510/M4512 processor (both read and write) via the least significant byte located at the starting address of the slot the S4520-RDC is located in. The processor section of the S4520-RDC implements the same set of special function registers that the M4500 does with the exception of the differences listed in the following sections.

The S4520-RDC is designed to interface with the Advanced Motion Control, Inc. (AMC) line of Brushless Servo Amplifiers, thus the built-in I/O reflects the specifics of interfacing with AMC amplifiers.

---

## Inputs

The S4520-RDC incorporates the following inputs: primary resolver reference from back-plane (0-4095 12-bit value), servo resolver feedback reference (0-4095 12-bit value), two 10-30VDC digital interrupt inputs, one +/-10V absolute value 10-bit analog input, and one amplifier fault input (TTL).

The primary resolver reference is derived from the resolver-to-digital converter section of the M4510 or M4512 that the S4520-RDC is mounted in. Thus the resolver that is connected to the standard M4510/M4512 resolver input is considered the primary resolver to be tracked. The RDC in the M4510/M4512 converts the resolver position to digital and then passes this information directly to the S4520-RDC via the back-plane of the M4510/M4512. Note that this information is not passed thru the M4510/M4512 processor but is instead the "raw" data updated immediately and continuously from the RDC of the M4510/M4512. This data is a 0-4095 (12-bit) value which represents the position of the primary resolver. The primary resolver reference is mapped to the special function register W196. This is updated once per timed interrupt scan.

The servo resolver feedback reference is derived from the on-board RDC section of the S4520-RDC. This is where the feedback resolver mounted in the servo motor being controlled would be wired to. The RDC section of the S4520-RDC converts the servo resolver position to a 0-4095 (12-bit) value and stores this in the special function register W194. This is updated once

per timed interrupt scan.

The two 10-30VDC digital interrupt inputs (IN0 and IN1) are identical to the two interrupt inputs built-into the M4500 modules. These are true differential inputs that can be wired as either sinking or sourcing and can be used either as interrupt inputs or standard inputs. When used as interrupt inputs, an "off" to "on" transition of IN0 initiates a call to ufunc00 while an "off" to "on" transition of IN1 calls ufunc01. When used as standard inputs, IN0 and IN1 are mapped just as they are in the M4500 modules (see the M4500 Program Development Manual).

The +/-10V absolute value analog input is a 0-1023 (10-bit) value that is mapped to special function register W162 which is updated once every timed interrupt scan. This input accepts a minus 10Volt to plus 10Volt input and converts it to the absolute value of this input with 0 equal to 0 volts and 1023 equal to -10 or +10volts. This input is generally mapped to the "torque" output of the servo amplifier so that the instantaneous magnitude of the servo motor torque can be monitored, either to detect an overload or to generate torque signatures.

The amplifier fault input is a TTL (0 to 5VDC) input that is mapped to the TTL fault output of the servo amplifier. This input is mapped to special function register F989 which is updated once per main scan. F989 is a "0" when the input is at 0volts (no fault) and a "1" when the input is at 5volts (fault).



## Outputs

The S4520-RDC incorporates the following outputs: two +/-10V bipolar 12-bit analog outputs, one amplifier enable output (TTL), and three HALL sensor emulation outputs (TTL).

The two +/-10V bipolar analog outputs are 12-bit (0-4095) outputs mapped from special function registers W166 (AOUT0) and W168 (AOUT1) which are update once per timed interrupt scan. Writing a value of "0" to W166 will output -10volts on AOUT0. Writing a value of 2047 will output 0volts while writing a value of 4095 will output +10volts. Generally AOUT0 is used as the "torque" command to the servo amplifier (a minus voltage produces a negative torque while a plus voltage produces a positive torque). AOUT1 functions identically as AOUT0 and is available as a generally purpose analog output for trouble-shooting etc.

The amplifier enable output is a TTL (0-5VDC) output mapped from special function register F990 which is updated once per main scan. Writing a "0" to F990 sets the output to 5volts, writing a "1" sets it to 0volts. This output is generally wired to the INHIBIT input of the servo amplifier. Writing a "1" to F990 enables the amplifier.

The three HALL sensor emulation outputs (TTL) are derived directly from the RDC section of the S4520-RDC and emulate the action of HALL sensors providing the correct commutation for the brushless servo motor. These are wired directly to the respective HALL sensor inputs of the servo amplifier. These are not under any software control of the S4520-RDC.

---

## Installation

Prior to installing the S4520-RDC, the I/O slot addressing dip switch on the board must be set for the slot the board will be addressed as.

**Note:** Geographical addressing is not used in the M4500. The slot the S4520-RDC is addressed as is solely defined by the dip switch settings on the S4520-RDC itself not by the slot in the M4500 chassis that the board is placed in. Two poles on the dip switch of the board set the binary slot address of the board as follows:

### S4520 SW1 Dip Switch Slot Addressing

<u>2</u>	<u>1</u>	<u>Slot Address</u>
off	off	0
off	on	1
on	off	2
on	on	3

The SW1 Slot address dip switch is located in the lower left hand corner of the component side of the S4520-RDC. The respective switch pole is "on"

when in either the "on" or "close" position and "off" when either in the "off" or "open" position depending on the type of dip switch used.

To install the S4520-RDC in the M4500 chassis, turn power to the M4500 "off" and remove the cover plate of the M4500 by loosening the captive screws that retain it. Install the S4520-RDC in the respective slot of the M4500, making sure the DIN connector on the S4520-RDC fully mates with the DIN connector in the M4500 motherboard and that the top of the S4520-RDC is seated correctly in the card guides at the top of the M4500. Install the M4500 cover back onto the M4500 making sure the LED's and Field connector protrude through the respective openings in the cover. The M4500 cover will retain the S4520-RDC both from the top and the front, holding the S4520-RDC in place during normal operation. Tighten the captive screws that retain the cover on the M4500. Install the female field wiring connector to the corresponding male connector on the S4520-RDC. The S4520-RDC is now installed and ready to run. To remove the S4520-RDC, simply perform the previous steps in reverse.



**S4520-RDC: MOTION CONTROL CO-CPU**  
**WITH RESOLVER FEEDBACK**

**Specifications**

**Board Size:**

Length:	6.50"
Height:	4.25"
Width:	0.80"

**Processor Section:**

**Memory:**

Program memory:	32K bytes battery backed CMOS RAM
Data memory:	8K bytes battery backed CMOS RAM

**Execution Times:**

Scan Time:	0.25msec per 1K bytes (typ)
Main program overhead:	0.10msec-0.20msec
Minimum Through-put:	0.08msec (using timed interrupt)

**Program Interface Port:**

Type:	RS-232
Comm Rate:	9600 BAUD

**RDC (Resolver-to-Digital Converter) Section:**

Resolution:	12 bits (0-4095)
Accuracy:	10 arc mins + 1LSB
Tracking Rate (R-to-D):	10,000 RPM
Tracking Rate (S4520-RDC):	6,000 RPM
Rotor Reference Output (RI-R2):	
Output Voltage Level:	3.7VRMS
Output Frequency:	2,500HZ
Stator Inputs (S1-S3, S2-S4)	
Input Voltage:	2.0VRMS (max)
Input Impedance:	100K ohms (typ)

**+/-10V Absolute Value Analog Input:**

Number of Inputs:	1
Input Range:	-10Volt to +10Volt
DC Input Resistance:	1M ohms or greater
Maximum Input Voltage:	+/-30 Volts
Accuracy:	0.5%
Repeatability:	0.1%
Analog-to-Digital Conversion Method:	Successive Approximation
Analog-to-Digital Conversion Time:	20 microseconds
Resolution:	10-bit (0-1023)



**S4520-RDC: MOTION CONTROL CO-CPU  
WITH RESOLVER FEEDBACK**

**Specifications (cont'd)**

**10-30VDC Digital Interrupt Inputs:**

Number of Inputs:	2
Vin (on-min):	10.0 volts
Vin (on-max):	30.0 volts
Vin (off-min):	5.0 volts
Input Current (max):	14 milliamps at Vin=30volts
Input Filter Delay (typ):	25 microseconds
Input Optical Isolation:	1500 Vrms

**Amplifier Fault Input:**

Number of Inputs:	1
Input Type:	TTL
Vin (off-max):	0.8 volts
Vin (on-min):	2.4 volts
Input Current (max):	1.2 milliamps at Vin=0volts
Input Filter Delay:	none

**+/-10V bipolar 12-bit analog outputs:**

Number of Outputs:	2
Output Range:	-10Volt to +10Volt
Load Resistance:	2K ohms or greater
Accuracy:	0.5%
Repeatability:	0.1%
Digital-to Analog Conversion Time:	15 microseconds
Resolution:	12-bit (0-4095)
Short Circuit Duration:	continuous

**Amplifier Enable Output and HALL Sensor Emulation Outputs:**

Number of Outputs:	4 (one amplifier enable, three HALL)
Output Type:	TTL
Vout (off-max):	0.8 volts
Vout (on-min):	2.4 volts
Output Current (max):	30 milliamps at Vout=0.2volts

**Power Requirements:**

Icc+5V (typ – M4500 bus):	0.5 amps
Icc+12V (typ – M4500 bus):	100 milliamps
Icc-12V (typ – M4500 bus):	50 milliamps

**Temperature Ranges:**

Storage:	0 to 85 degrees C
Operating:	0 to 60 degrees C

**Relative Humidity:**

5 to 95% non-condensing



# S4520-RDC: MOTION CONTROL CO-CPU WITH RESOLVER FEEDBACK

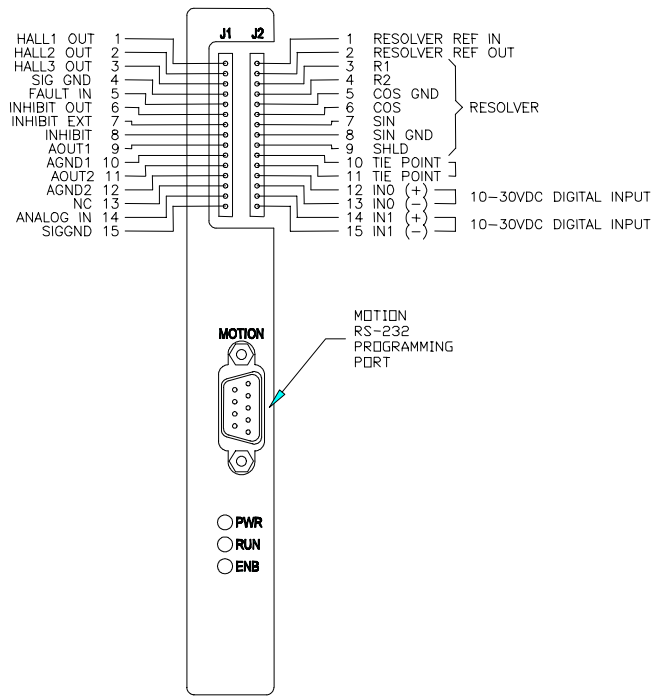

**Figure 1**  
S4520-RDC Faceplate

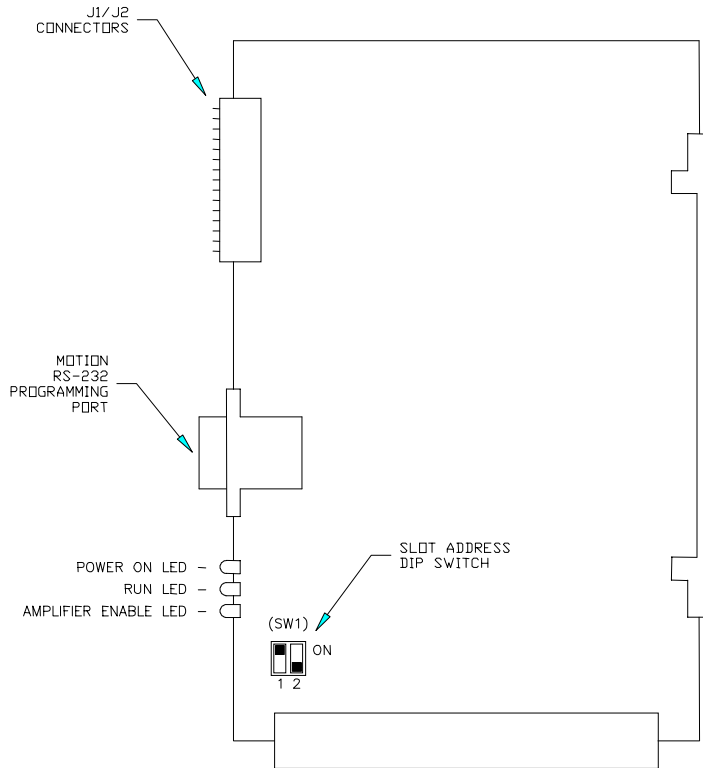

**Figure 2**  
S4520-RDC Board Outline



## S4520-RDC: MOTION CONTROL CO-CPU WITH RESOLVER FEEDBACK

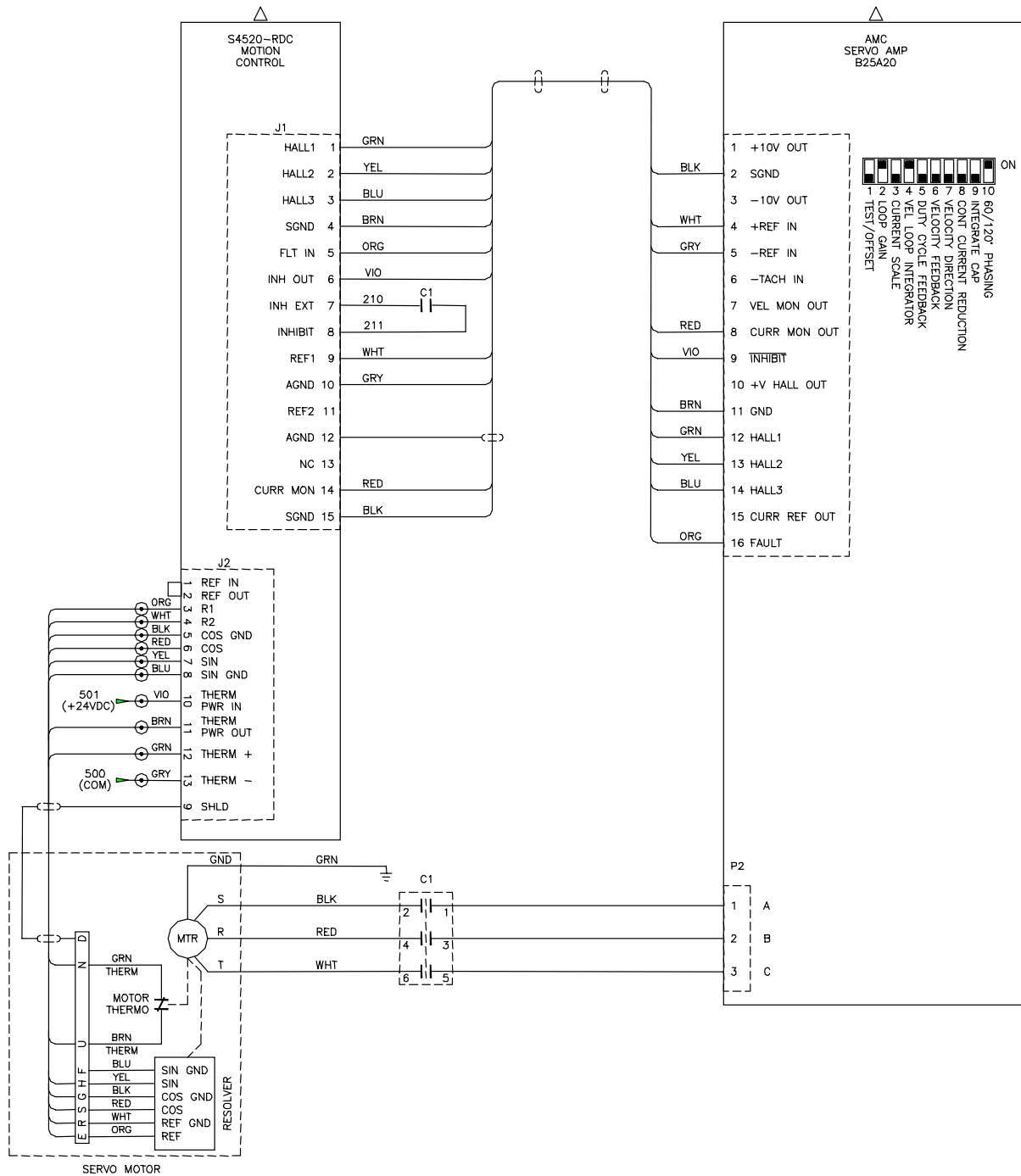

Figure 3  
Typical Interconnect Wiring with AMC Amplifier

