



**KT\***  
**SOLENOID OPERATED  
CARTRIDGE, POPPET TYPE  
SERIES 1**

**CARTRIDGE TYPE**

seat SAE 08, SAE 10 and SAE 12

**p** max **350** bar

**Q** max **150** l/min

**OPERATING PRINCIPLE**

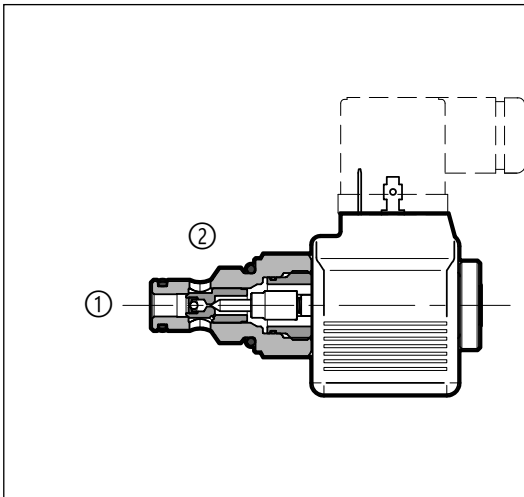

- The KT\* are 2-port pilot operated poppet valves, actuated by solenoid. They are available in three nominal sizes, in normally closed versions (NC) and in normally open versions (NO).
- Single flow, reverse flow and double seal designs are available, with maximum flow rate up to 150 l/min.
- KT\* valves ensure a low internal leakage, which decreases while the pressure increases.
- Coils for DC power supply with standard connection type EN 175301-803 (ex DIN 43650), AMP Junior or DEUTSCH are available.
- The manual override is available as option (see point 19).

**PERFORMANCES**

(working with mineral oil of viscosity of 36 cSt at 50°C)

		KT08	KT10	KT12
Maximum operating pressure	bar	350		
Nominal flow rate	l/min	40	80	150
Maximum internal leakage at 350 bar	cm <sup>3</sup> /min	0.25		
Pressure drops $\Delta p - Q$	view points 7, 9, 11, 13, 15			
Electrical characteristics	view point 16			
Electrical connections	EN 175301-803 (ex DIN 43650) / AMP Junior / DEUTSCH			
Ambient temperature range	°C	-20 / +50		
Fluid temperature range	°C	-20 / +80		
Fluid viscosity range	cSt	10 ÷ 400		
Fluid contamination degree	according to ISO 4406:1999 class 20/18/15			
Recommended viscosity	cSt	25		
Mass	kg	0.1 ÷ 0.5	0.2 ÷ 0.6	0.25
Surface treatment of the cartridge	zinc coating (salt spray resistance: 96 h)			

### 1 - IDENTIFICATION CODE

	<b>K</b>	<b>T</b>	<b>-</b>	<b>2</b>		<b>-</b>		<b>-</b>	<b>N</b>	<b>-</b>	<b>1</b>
--	----------	----------	----------	----------	--	----------	--	----------	----------	----------	----------

Cartridge solenoid valve

Poppet type valve

Nominal body dimension:  
**08** = 3/4-16 UNF-2A  
**10** = 7/8-14 UNF-2A  
**12** = 1 1/16-12 UN-2A

2-port

Seals (see hydraulic symbols and table for availability):  
**S** = standard seal (from 2 to 1)  
**R** = reverse seal (from 1 to 2)  
**D** = double seal

Initial position:  
**NC** = normally closed  
**NO** = normally open

**Availability**

	nominal dimension		
	08	10	12
2SNC	■	■	■
2RNC	■	■	-
2DNC	■	-	-
2SNO	■	■	-
2DNO	■	-	-

Series Number

Manual override (see point 19):  
**N** = no override, blind  
**K2** = push and twist

NBR seal for mineral oil

Coil electrical connection (see point 17):  
**K1** = plug for connector type EN 175301-803 (ex DIN 43650) (**standard**)

For **D12** and **D24** coils only:  
**K2** = plug for connector type AMP JUNIOR  
**K7** = plug DEUTSCH DT04-2P for male connector type DEUTSCH DT06-2S

DC power supply :  
**D00** = valve without coil (the coil locking ring and the related OR are supplied)  
**D12** = 12 V  
**D24** = 24 V  
**D110** = 110 V  
**D220** = 220 V

### 2 - HYDRAULIC SYMBOLS

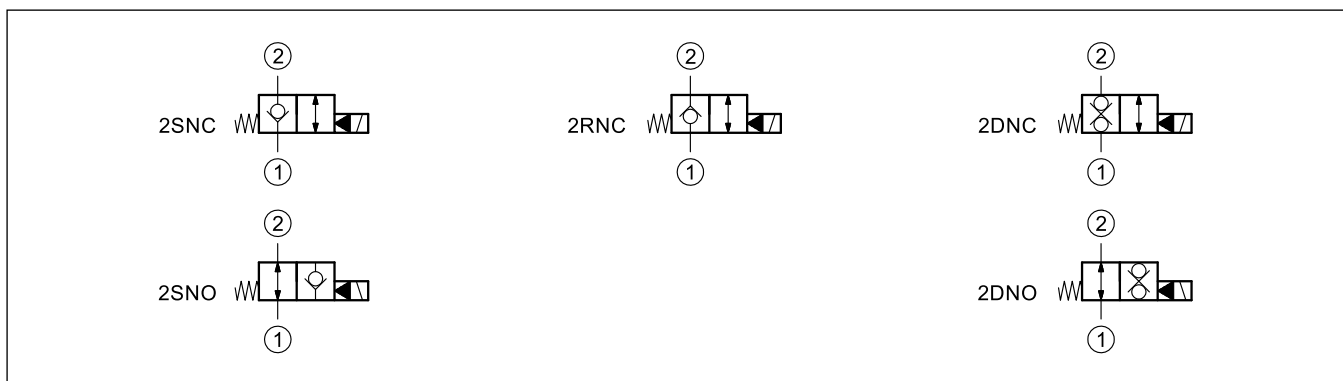

### 3 - HYDRAULIC FLUIDS

Use mineral oil-based hydraulic fluids HL or HM type, according to ISO 6743-4. For these fluids, use NBR seals (code N). For fluids HFDR type (phosphate esters) use FPM seals (code V). For the use of other fluid types such as HFA, HFB, HFC, please consult our technical department.

Using fluids at temperatures higher than 80 °C causes a faster degradation of the fluid and of the seals characteristics. The fluid must be preserved in its physical and chemical characteristics.

### 4 - SWITCHING TIMES

The values indicated refer to a valve tested with  $Q = 25$  l/min,  $p = 350$  bar, with mineral oil at a temperature of 50°C and a viscosity of 36 cSt.

TIMES [ms]		
	ENERGIZING	DE-ENERGIZING
KT08-2SNC, KT08-2SNO, KT08-2RNC, KT10-2SNC	30	60
KT08-2DNC	30 ÷ 40	60 ÷ 80
KT10-2RNC	50	70
KT08-2DNO, KT10-2SNO	100	50
KT12-2SNC	40	90

### 5 - SEAT DIMENSIONS FOR SAE CARTRIDGE VALVES

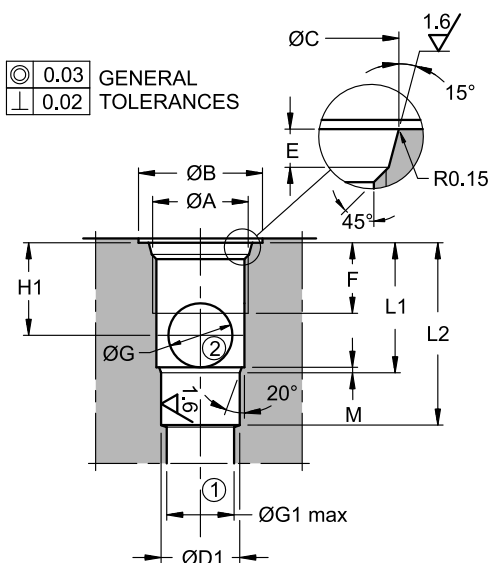

	KT08	KT10	KT12
cavity	SAE 08-2N	SAE 10-2N	SAE 12-2N
ØA	3/4-16 UNF-2B	7/8-14 UNF-2B	1-1/16 12 UN-2B
ØB	26	30	35
ØC	20.6 <sup>+0.1</sup> <sub>0</sub>	23.9 <sup>+0.1</sup> <sub>0</sub>	29.2 <sup>+0.1</sup> <sub>0</sub>
ØD1	12.7 <sup>+0.05</sup> <sub>0</sub>	15.87 <sup>+0.05</sup> <sub>0</sub>	22.22 <sup>+0.05</sup> <sub>0</sub>
E	2.6 <sup>+0.3</sup> <sub>0</sub>	2.6 <sup>+0.3</sup> <sub>0</sub>	3.3 <sup>+0.3</sup> <sub>0</sub>
F	13	15	20
ØG	9	11.75	18
ØG1 max	12	15	19
H1	14	17.5	25.3
L1	20.5 <sup>±0.3</sup>	25.5 <sup>±0.3</sup>	36.5 <sup>±0.3</sup>
L2	29 <sup>±0.3</sup>	34.5 <sup>±0.3</sup>	48 <sup>±0.3</sup>
M	1.5	1.5	1.6

### 6 - KT08-2\*NC - OVERALL AND MOUNTING DIMENSIONS

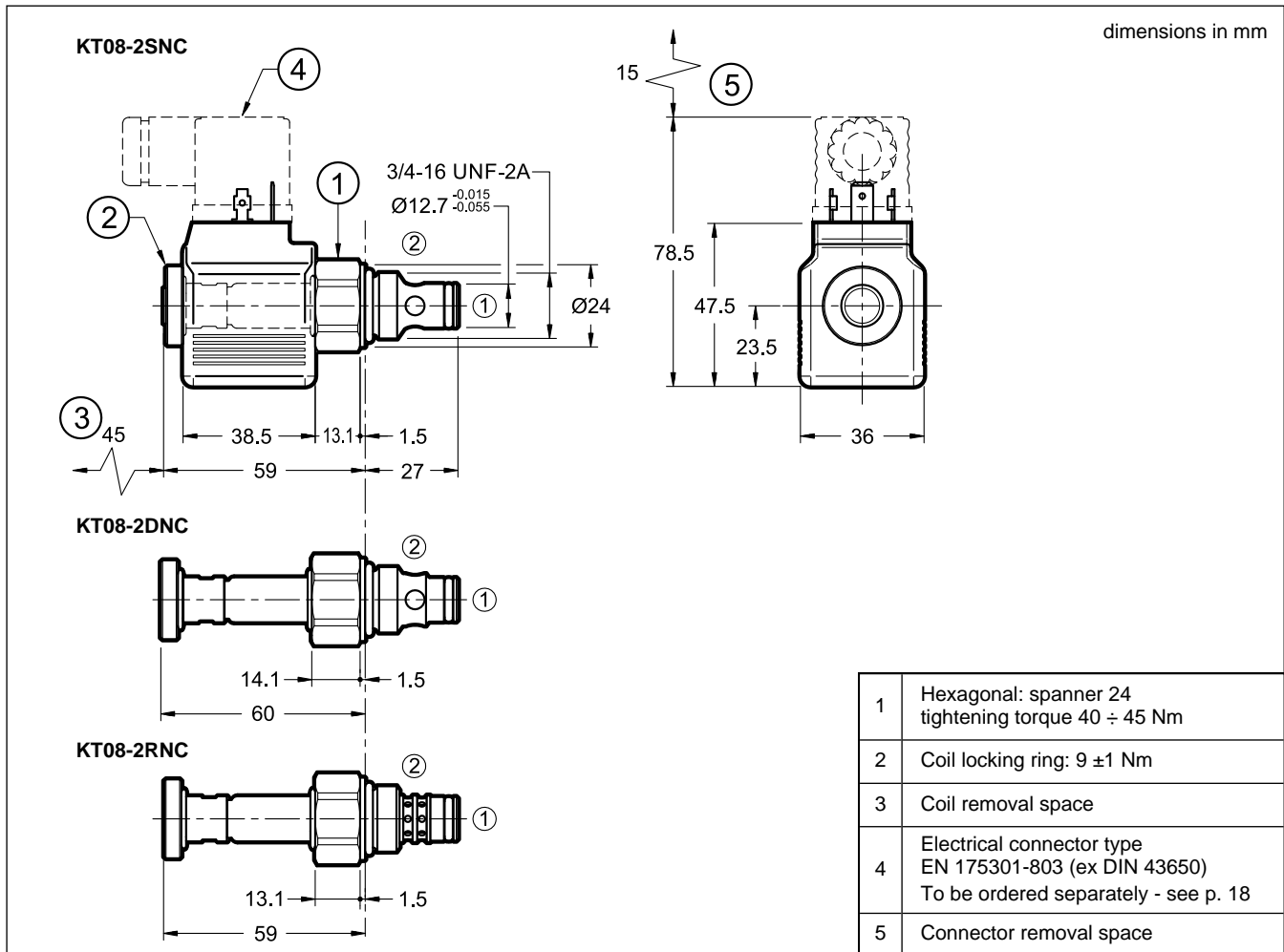

### 7 - KT08-2\*NC - PRESSURE DROPS

(Obtained with viscosity 46 cSt at 40 °C, minimum voltage 90% nom.)

#### 7.1 - KT08-2SNC

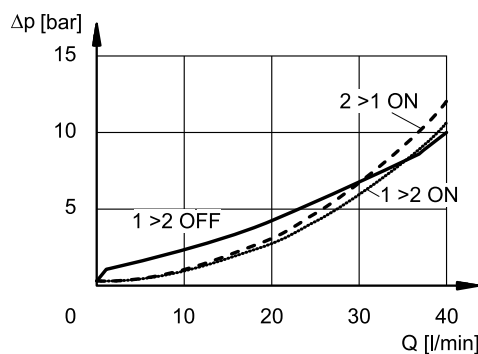

#### 7.2 - KT08-2DNC

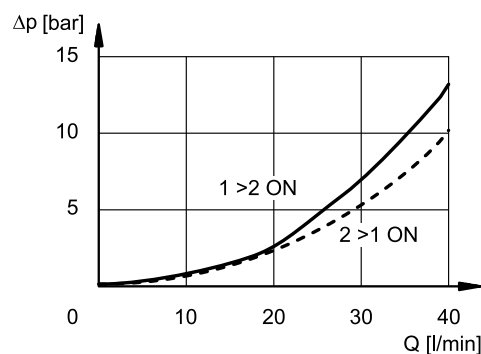

#### 7.3 - KT08-2RNC

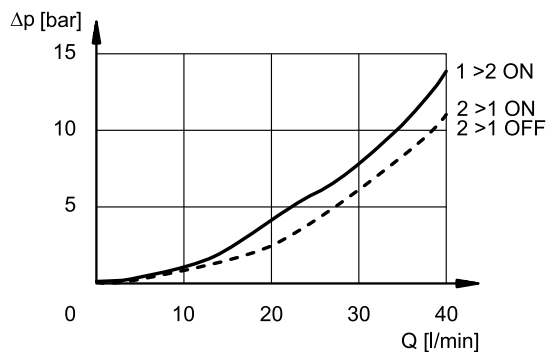

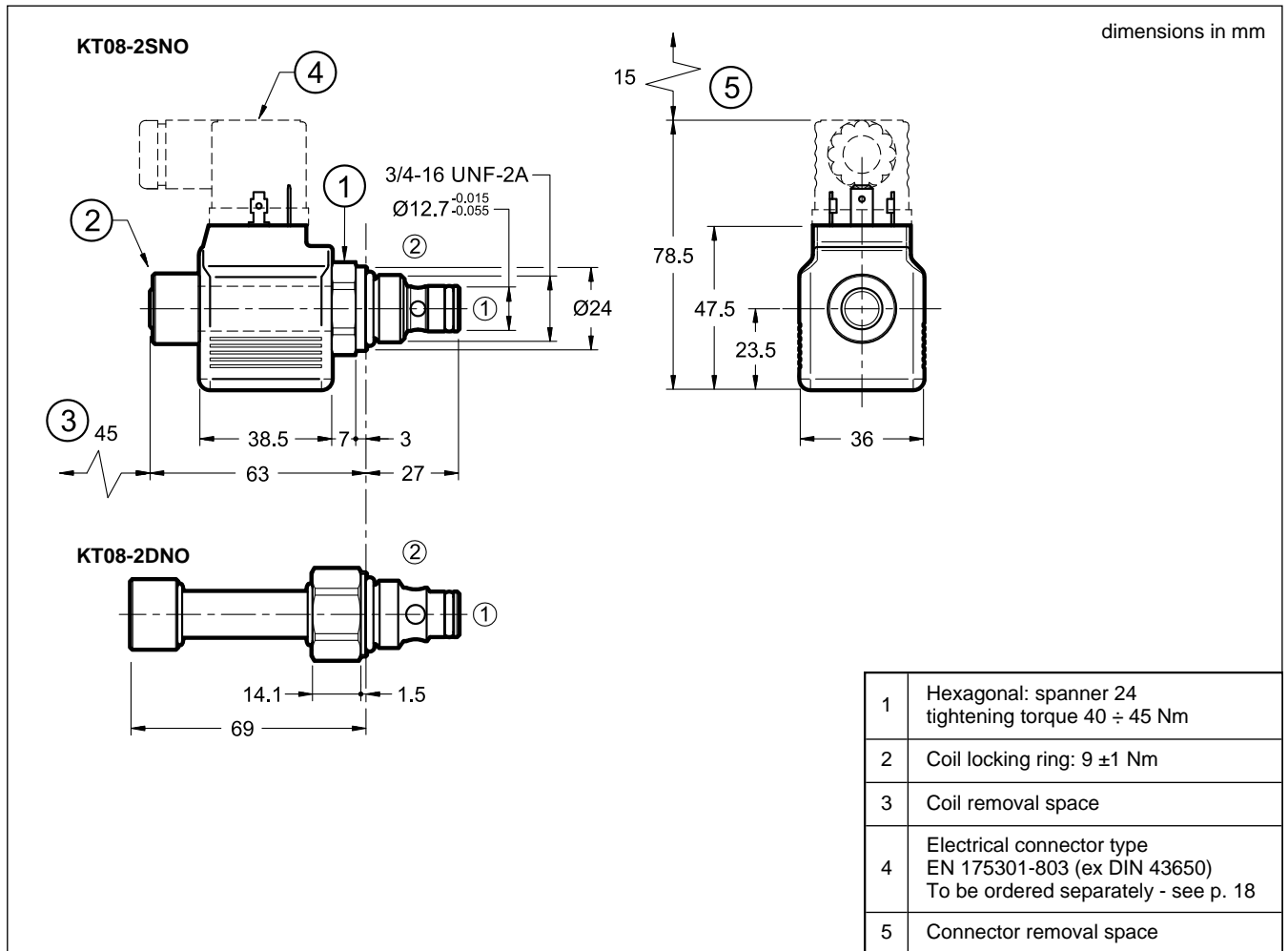
**8 - KT08-2\*NO - OVERALL AND MOUNTING DIMENSIONS**

**9 - KT08-2\*NO - PRESSURE DROPS**

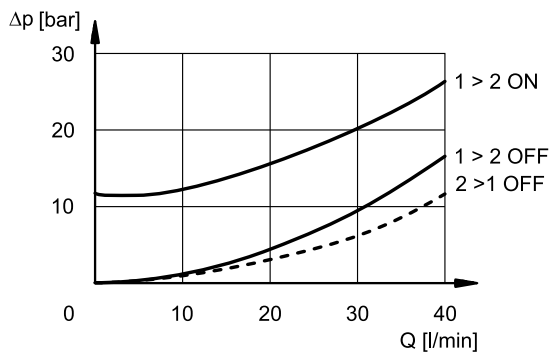
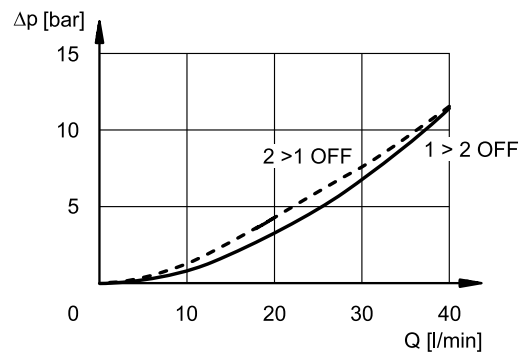
(Obtained with viscosity 46 cSt at 40 °C, minimum voltage 90% nom.)

**9.1 - KT08-2SNO**

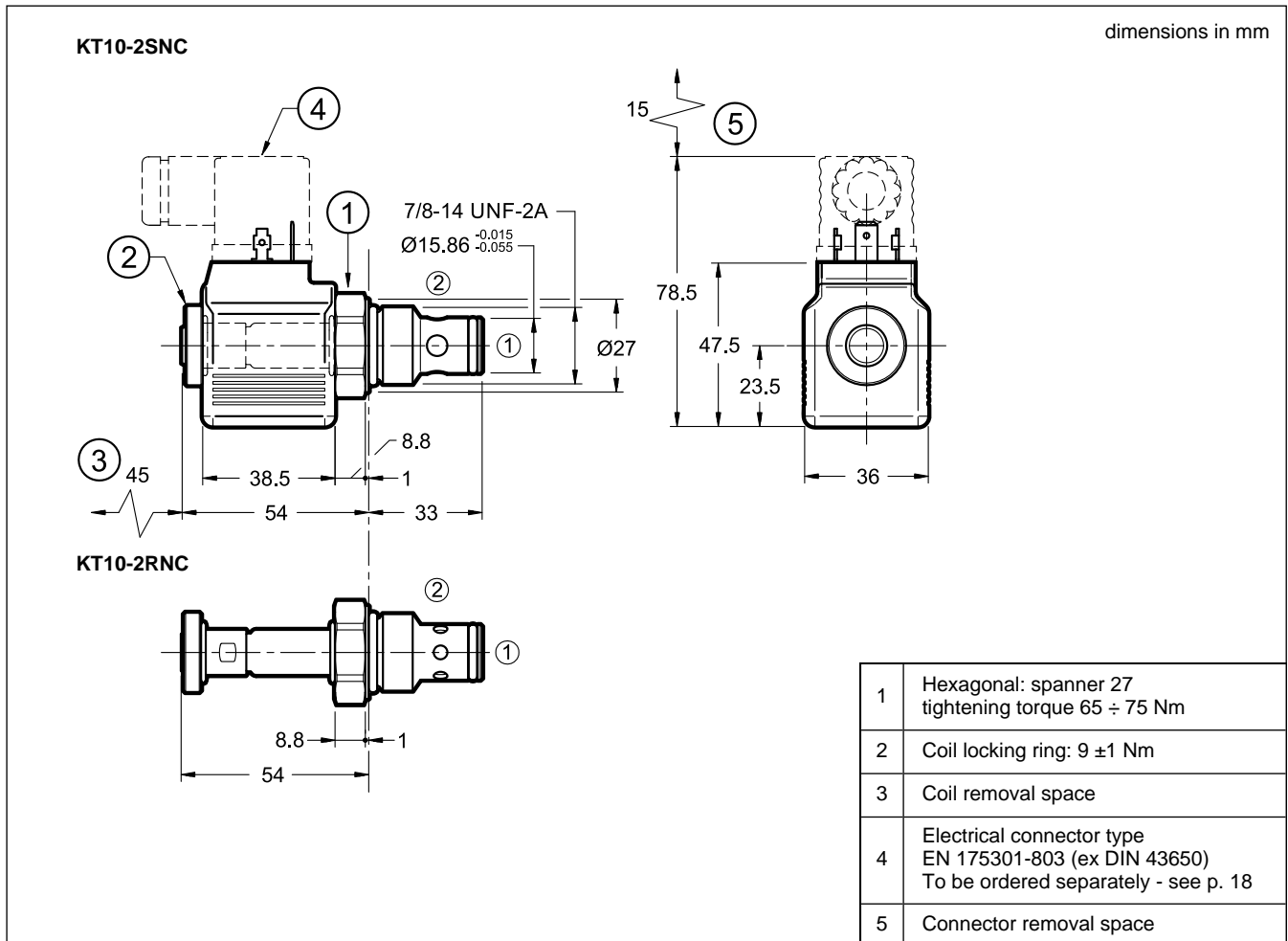
**9.2 - KT08-2DNO**

### 10 - KT10-2\*NC - OVERALL AND MOUNTING DIMENSIONS



### 11 - KT10-2\*NC - PRESSURE DROPS

(Obtained with viscosity 46 cSt at 40 °C, minimum voltage 90% nom.)

#### 11.1 - KT10-2SNC

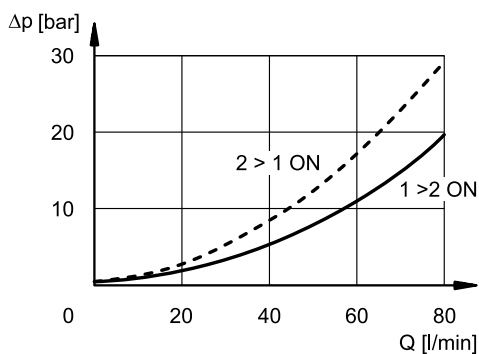

#### 11.2 - KT10-2RNC

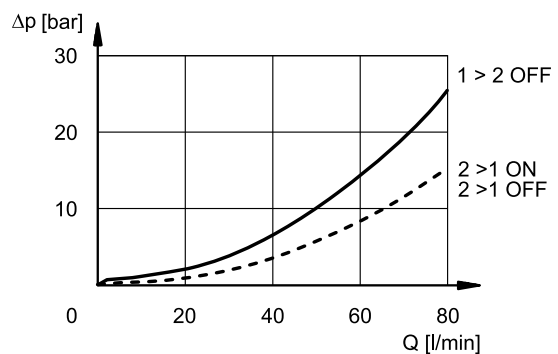

12 - KT10-2SNO - OVERALL AND MOUNTING DIMENSIONS

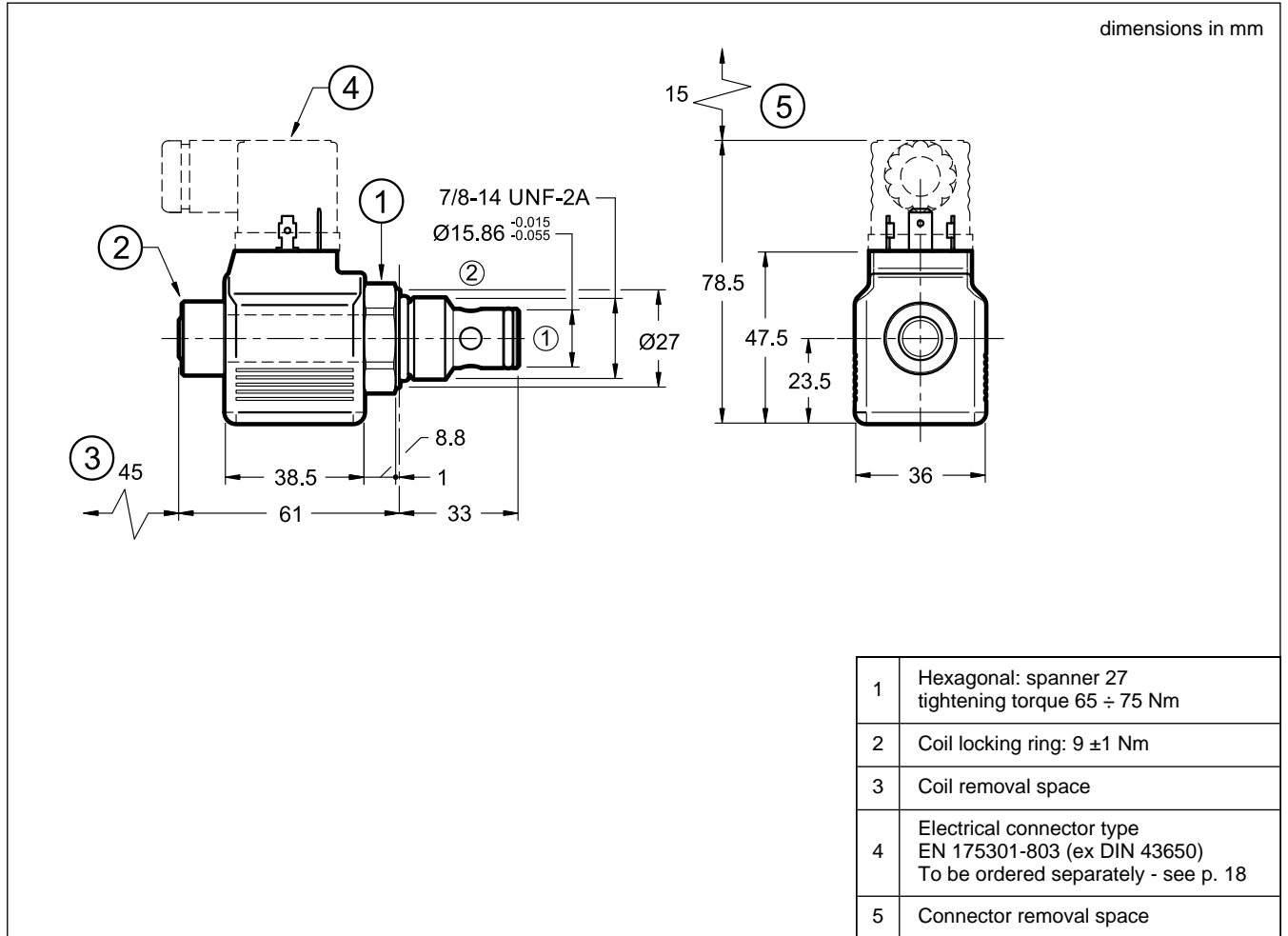

13 - KT10-2SNO - PRESSURE DROPS

(Obtained with viscosity 46 cSt at 40 °C, minimum voltage 90% nom.)

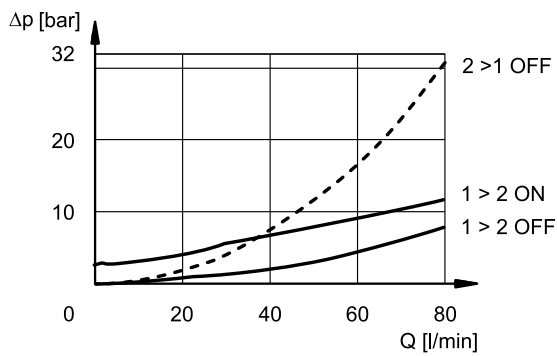

### 14 - KT12-2SNC - OVERALL AND MOUNTING DIMENSIONS

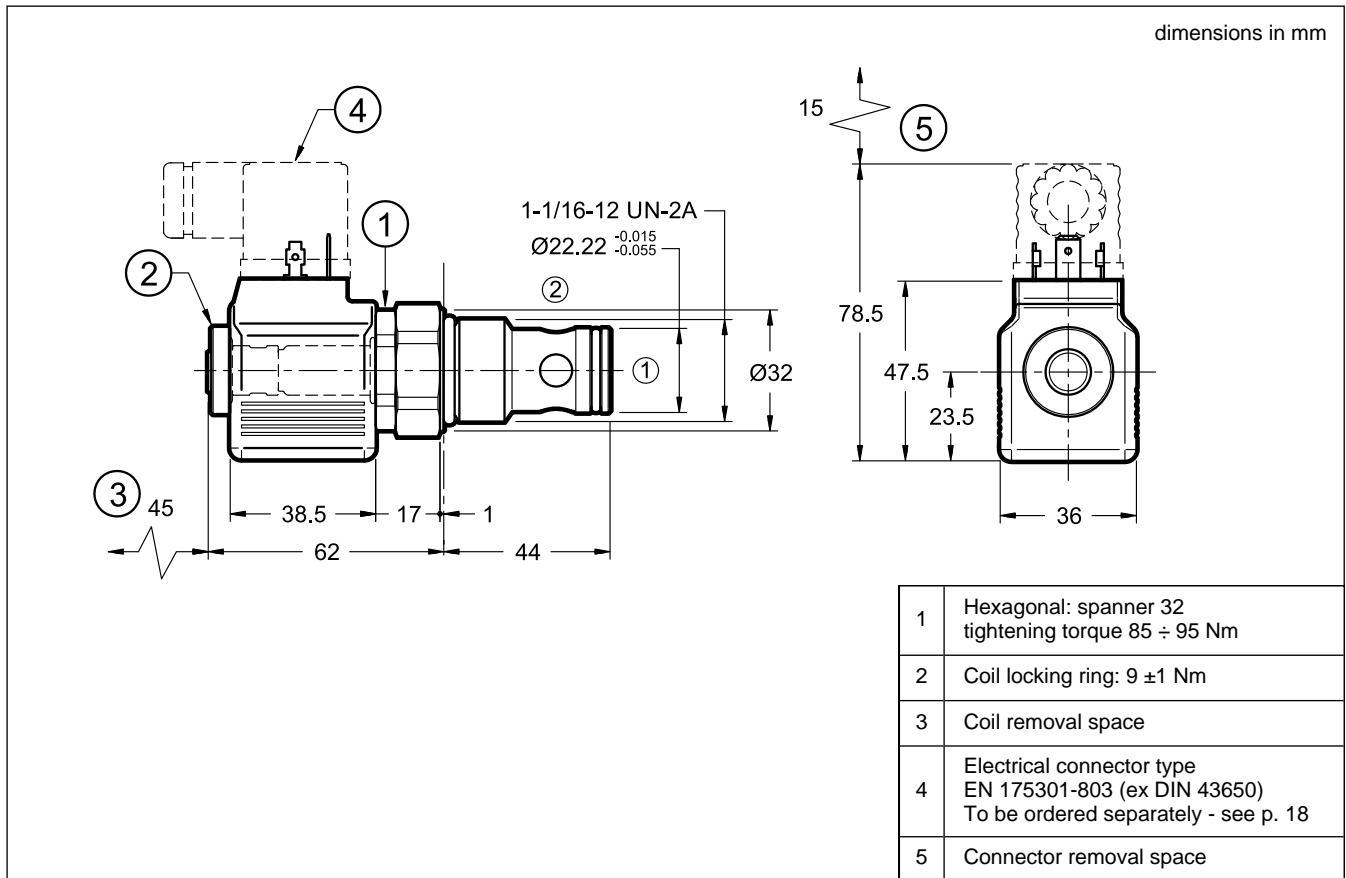

### 15 - KT12-2SNC - PRESSURE DROPS

(Obtained with viscosity 46 cSt at 40 °C, minimum voltage 90% nom.)

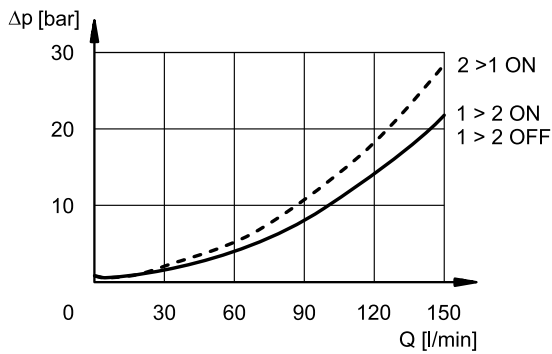

## 16 - ELECTRICAL FEATURES

### 16.1 - Solenoids

These are essentially made up of two parts: tube and coil. The tube is threaded into the valve body and includes the armature that moves immersed in oil, without wear. The inner part, in contact with the oil in the return line, ensures heat dissipation.

The coil is fastened to the tube by a threaded ring, and can be easily replaced. To replace the coil even with different voltage it is possible without replacing the tube.

#### Protection from atmospheric agents IEC 60529

The IP protection degree is guaranteed only with both valve and connectors of an equivalent IP degree, correctly connected and installed.

electric connection	electric connection protection	whole valve protection
<b>K1</b>	IP65	IP65
<b>K2</b>	IP65/67	
<b>K7</b>	IP65/67	

<b>SUPPLY VOLTAGE FLUCTUATION</b>	± 10% Vnom
<b>MAX SWITCH ON FREQUENCY</b>	10.000 ins/hour
<b>DUTY CYCLE</b>	100%
<b>ELECTROMAGNETIC COMPATIBILITY (EMC)</b>	In compliance with 2014/30/UE
<b>LOW VOLTAGE</b>	In compliance with 2014/35/UE
<b>CLASS OF PROTECTION</b> Coil insulation (VDE 0580) Impregnation	class H class F

### 16.2 - Current and absorbed power

The table shows the absorption values relating to the various types of coil for direct current power supply.

	Nominal voltage [V] (±10%)	Resistance at 20°C [Ω] (±7%)	Absorbed current [A]	Absorbed power [W]	Coil code		
					K1	K2	K7
<b>D12</b>	12	6.5	1.84	22	1904140	1904180	1904150
<b>D24</b>	24	26.2	0.92	22	1904141	1904181	1904151
<b>D110</b>	110	550	0.2	22	1904142	-	-
<b>D220</b>	220	2200	0.1	22	1904143	-	-

## 17 - ELECTRIC CONNECTIONS

connection for EN 175301-803 (ex DIN 43650) connector code **K1 (standard)**

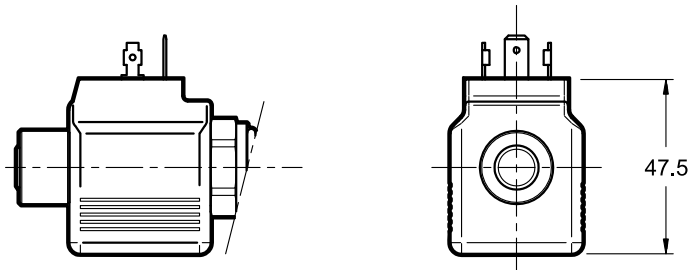

connection for AMP JUNIOR connector type code **K2**

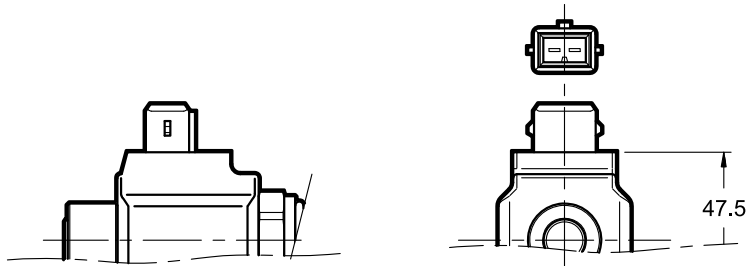

connection for DEUTSCH DT06-2S male connector type code **K7**

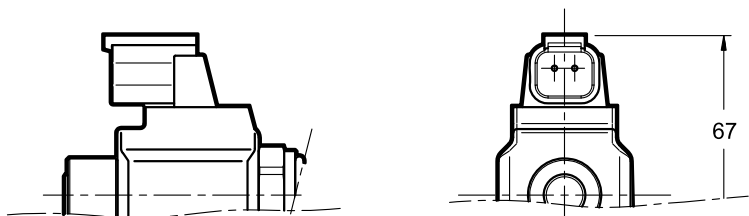

**18 - ELECTRIC CONNECTORS**

Solenoid valves are delivered without connectors. Connectors type EN 175301-803 (ex DIN 43650) for K1 connection can be ordered separately. See catalogue 49 000.

**19 - MANUAL OVERRIDE**

Valves can be delivered with push and twist manual override (K2 code) or without any override (N code).

The override is activated by pressing and turning the knob (clockwise for NO versions, anticlockwise for NC versions); it is deactivated by pressing and turning the knob again in the opposite direction. A small spring allows the knob to return to its initial position.

The shape is different depending on NC or NO version.

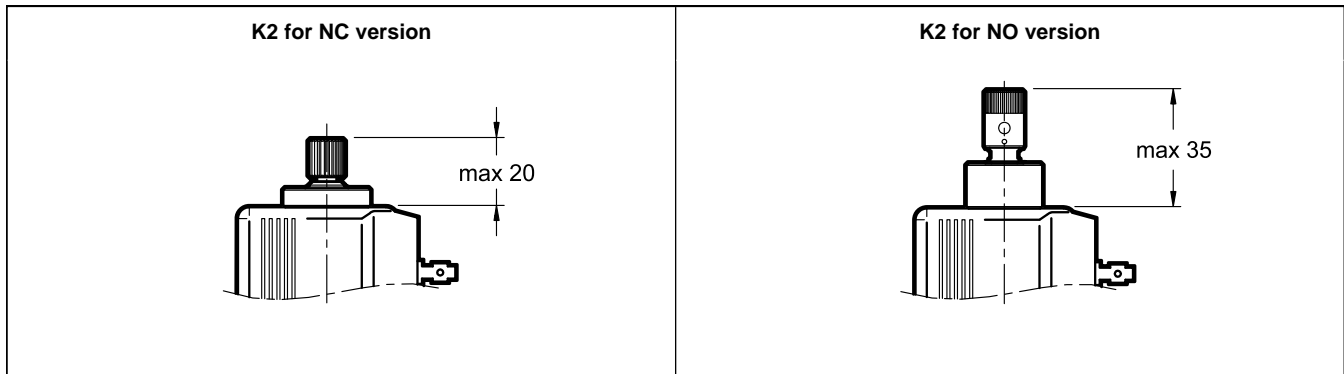

## 20 - KT08 SUBPLATES FOR MODULAR MOUNTING

### 20.1 - Identification code

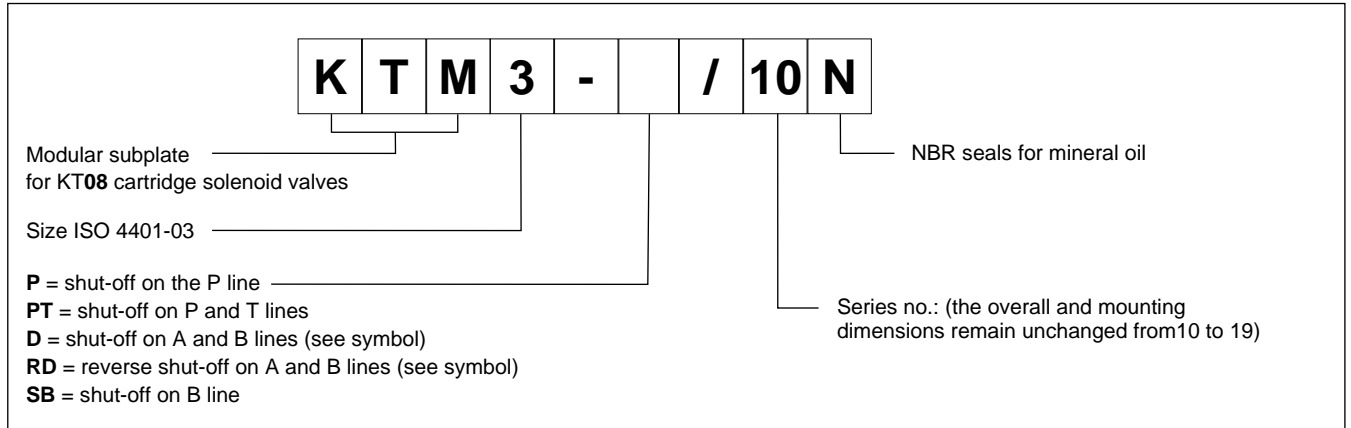

### MOUNTING INTERFACE

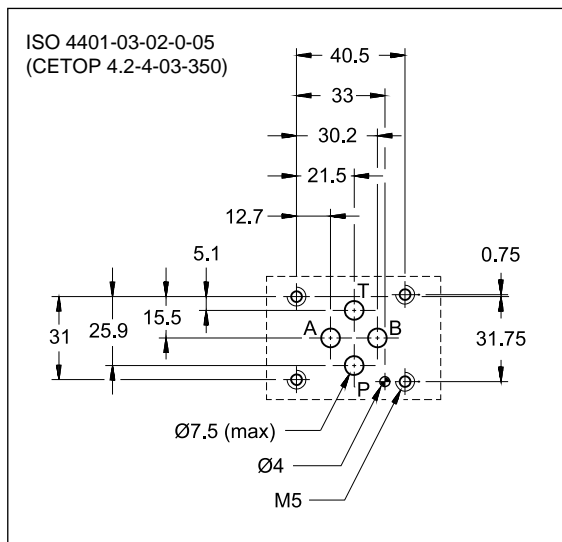

### HYDRAULIC SYMBOLS

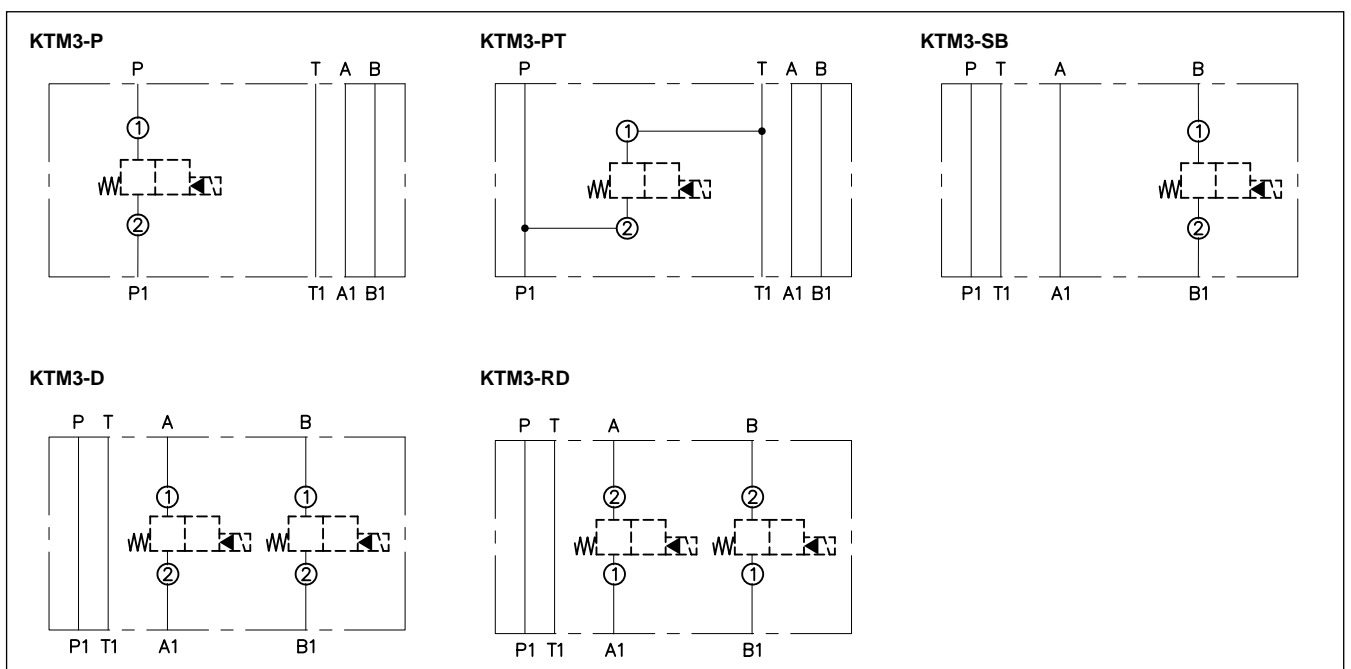

### 20.2 - Overall and mounting dimensions KTM3-P

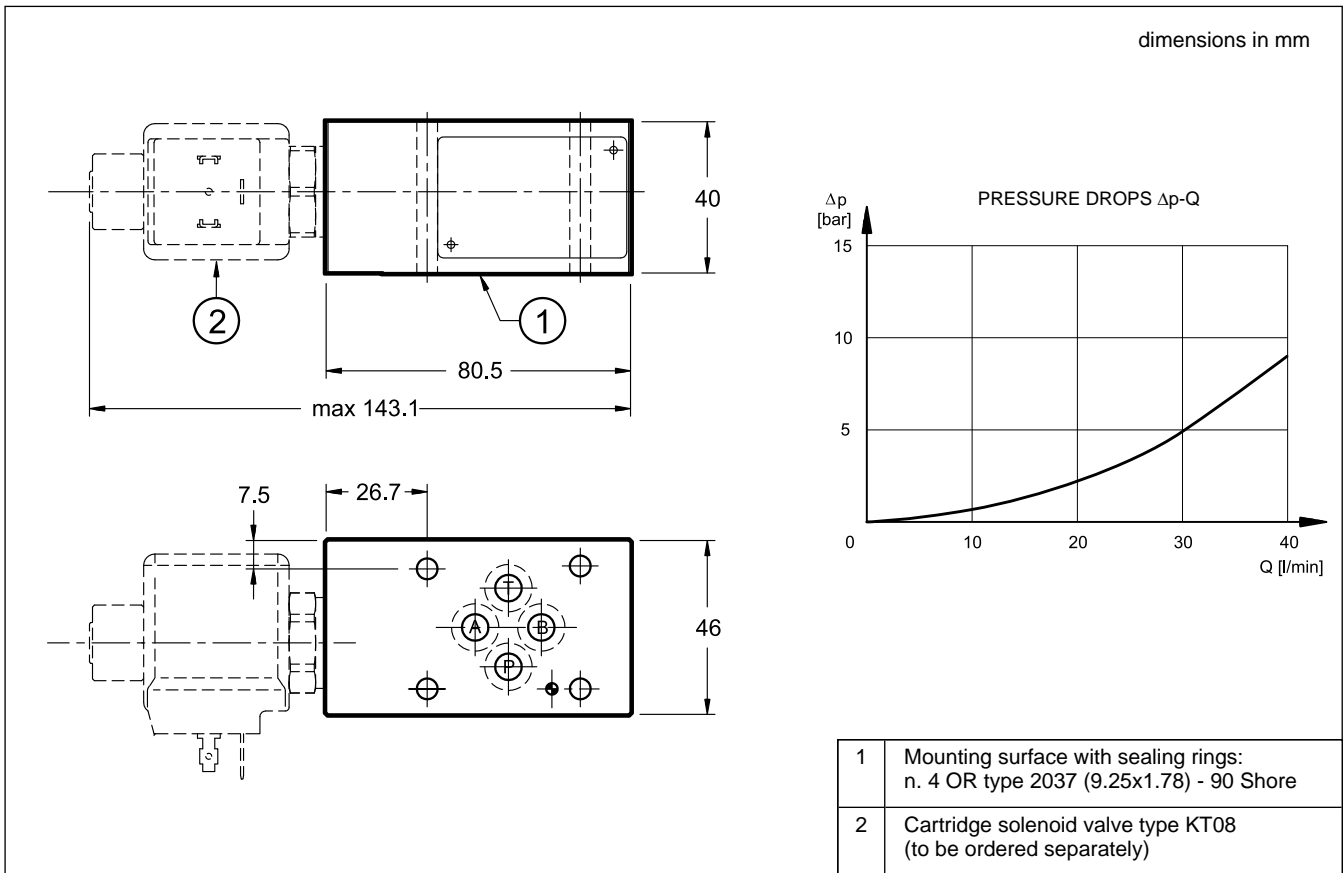

### 20.3 - Overall and mounting dimensions KTM3-PT

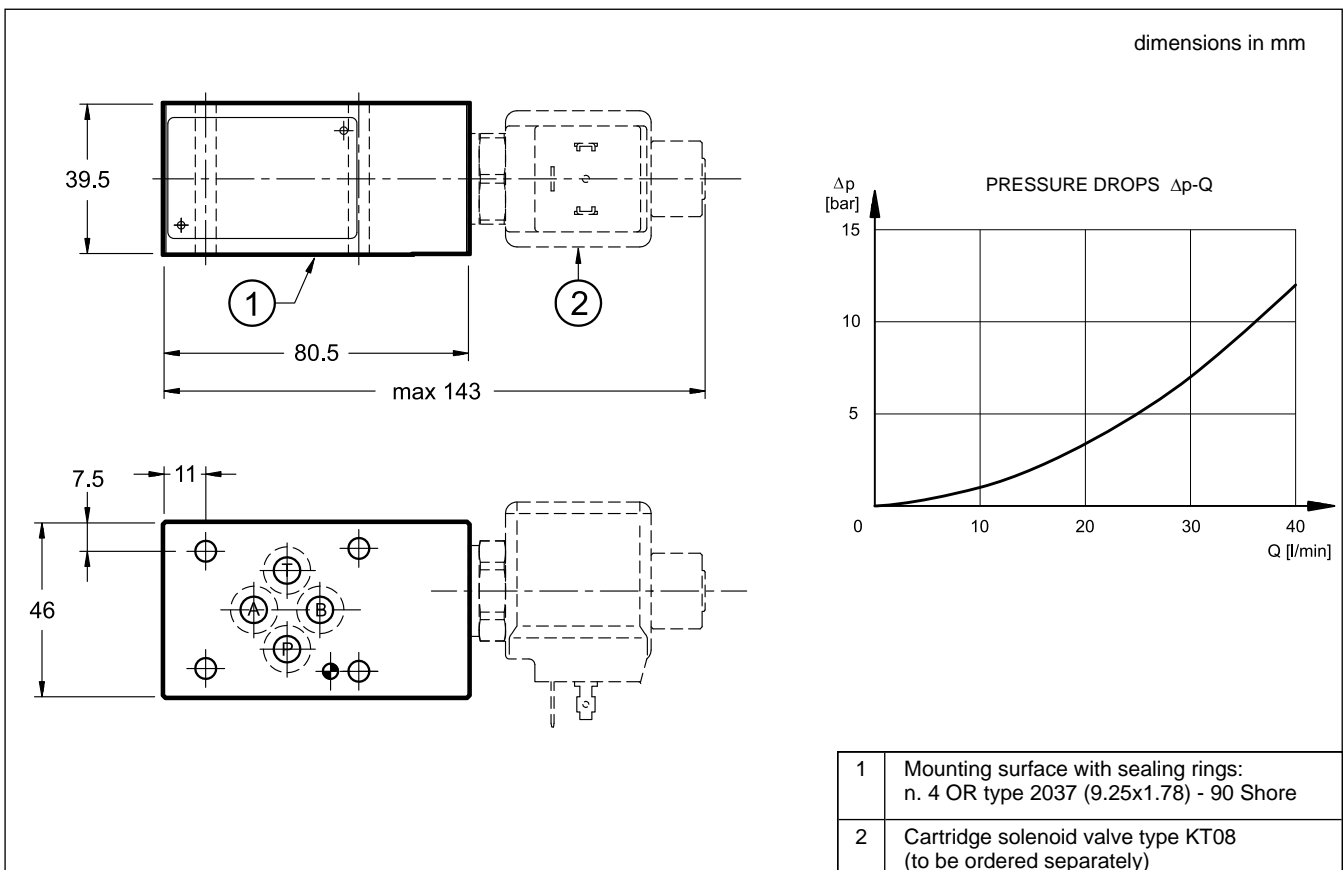

20.4 - Overall and mounting dimensions KTM3-D, KTM3-RD and KTM3-SB

