



892/894M DC Output Math Modules

Application Example

A typical application involves calculating the composite flow rate of several flows. The 894M easily sums up to four inputs and provides the total as an output scaled in engineering units.

Configuration Procedures

- 1) Enter optional tag identifiers and other desired application information.
- 2) Select your input ranges from the pull-down menus and identify the sources.
- 3) Select the output range and either normal or reverse acting (proportional/inverse) mode.

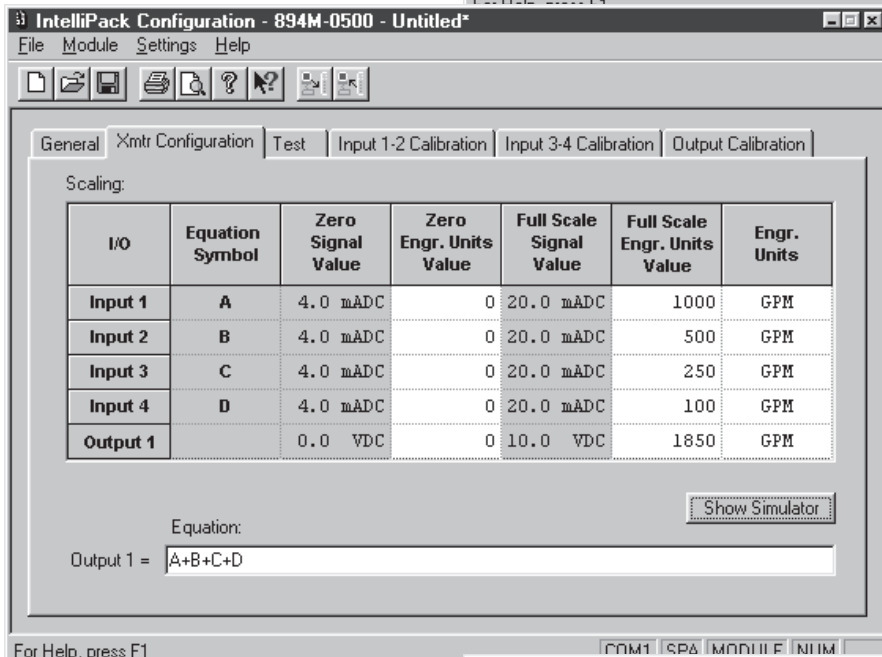
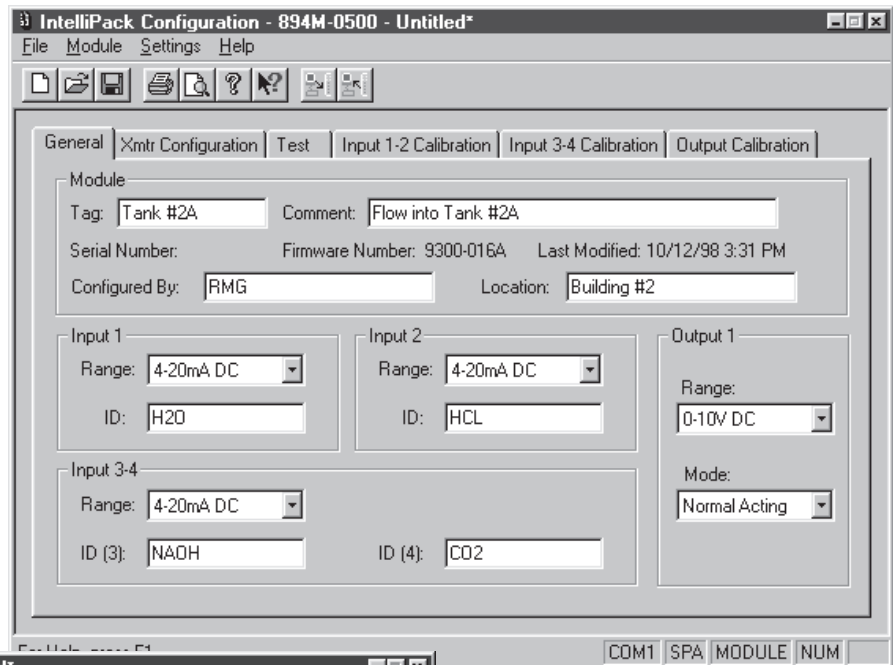

IntelliPack Configuration Software makes it very easy to set up your input and output ranges and other operational parameters.

- 4) Enter the zero/full scale values in engineering units for input variables A, B, C and D.
- 5) Enter the output scaling parameters, also in engineering units.
- 6) Enter your equation (up to 200-characters) in the equation field to define the output.
- 7) Use the I/O equation simulator (shown below) to verify the expected results for various field conditions.

The IntelliPack math module's configuration property sheet simplifies the entry of equations.

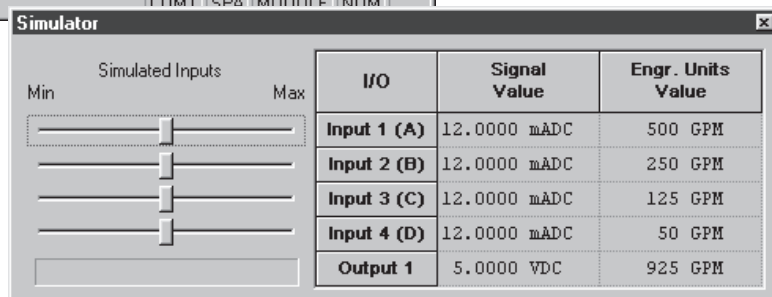

The pop-up simulator sheet helps you test equations in software with slider bars to simulate input conditions.



Real Time Monitoring

892/894M DC Output Math Modules

Models

892M-0500: Two input channels
894M-0500: Four input channels

Input Ranges

0 to 1mA, 0 to 20mA, or 4 to 20mA DC
0 to 5V or 0 to 10V DC
0 to 20A AC (with AC current sensor)

Output Ranges

0 to 1mA, 0 to 20mA, or 4 to 20mA DC,
0 to 5V or 0 to 10V DC

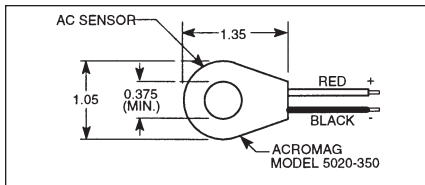

AC Current Sensor Model 5020-350 (ordered separately)

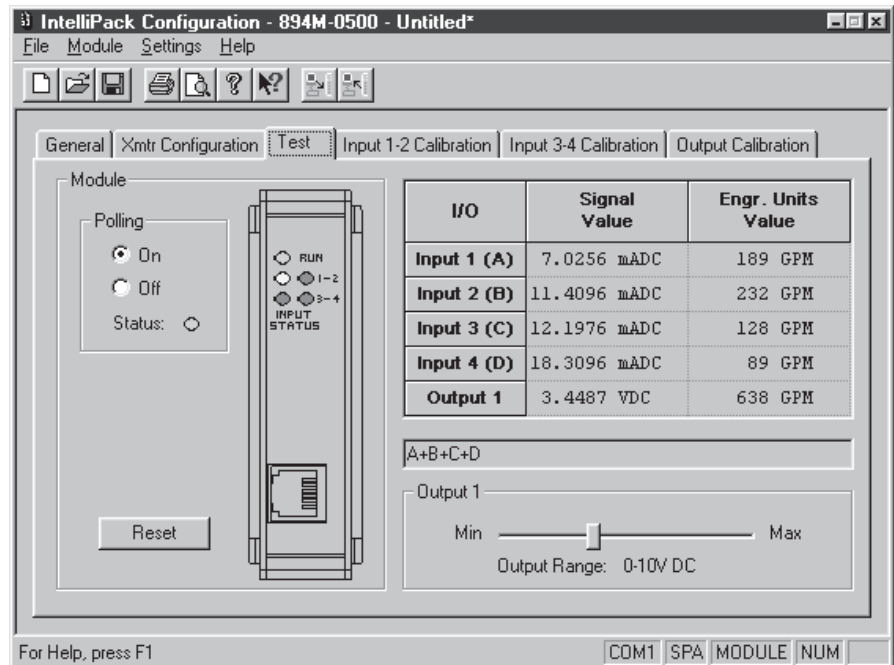

The test property sheet displays run-time input/output values for easy troubleshooting and diagnostics.

Arithmetic Functions

Function	Equation
Addition	$A+B+C+D$
Subtraction	$A - B+C - D$
Multiplication	$4*A - 2*B+3*C - 6*D$
Division	$(A/4+B/2 - 3*C)/8$
Square Root	$\text{SQRT}(A - B+C - D)$
Absolute Value	$\text{ABS}(A - B+C - D)$
Exponential	$\text{EXP}(2*A) = e^{2A}$
Power	$\text{POWER}(A, B) = A^B$
Natural Log	$\text{LN}(A+B)$
Log Base 10	$\text{LOG}_{10}(A/B)$
SIN, COS, TAN, ASIN, ACOS, ATAN	$\text{SIN}(A - B)$ $\text{ACOS}(A*B)$
Minimum	$\text{MIN}(A/2, B/4, 3*C, D)$
Maximum	$\text{MAX}((A - B)/4, C+D)$

Conditional

Function	Equation
If, Then, Else, And, Or, >, <, <=, =, >=, <=	$\text{IF}(A>B) \text{ THEN } (2*C)$ $\text{IF}(\text{OR}(A=B, B>=C)) \text{ THEN } (D)$

Track & Hold Function

A digital input on the math module accepts a logic level signal from PLCs and other devices to hold the output constant at the last known value.



■ 892/894M Performance Specs

■ General

Analog to Digital Converter (ADC)
16-bit Σ - Δ A/D converter.

Ambient Temperature Effect

Better than $\pm 0.005\%$ of input span per $^{\circ}\text{C}$ or $\pm 1\mu\text{V}$, whichever is greater.

Noise Rejection

Normal Mode: 40dB @ 60Hz, 100 ohm unbalance.
Common Mode: 100dB @ 60Hz, 100 ohm unbalance.
(49.9 ohm unbalance for process current inputs).

Response Time (for input step change)

800ms typical to 98% of final output value.

Input Overvoltage Protection

Bipolar Transient Voltage Suppressors (TVS).

■ DC Current Input

DC Current Input Ranges

Input Ranges	Resolution
0 to 1mA DC	0.0370%
0 to 20mA DC	0.0025%
4 to 20mA DC	0.0025%

DC Current Input Impedance

49.9 ohms.

DC Current Input Accuracy

Better than 0.05% of input span, typical.
Better than 0.3% of input span typ. for 0-1mA range.

■ DC Voltage Input

DC Voltage Input Ranges

Input Ranges	Resolution
0 to 5V DC	0.0030%
0 to 10V DC	0.0025%

Input impedance

Greater than 500K ohms.

DC Voltage Input Accuracy

Better than 0.05% of input span, typical.

■ Output (DC V/mA)

D/A Converter

16-bit Σ - Δ .

Current Output

Ranges: 0-1mA, 0-20mA, 4-20mA.
Compliance: 10V minimum (500 Ω load).
Accuracy: 0.025% of span (0-1mA: 0.3% of span).

Voltage Output

Ranges: 0-5V, 0-10V.
Compliance: 10mA maximum with short circuit protection. 1 ohm output impedance.
Accuracy: 0.025% of span.

Accuracy (overall input to output)

Better than 0.075% of span, typical.
Better than 0.5% of span for 0-1mA, typical

■ Environmental

Ambient Temperature

Operating: -25 to 70 $^{\circ}\text{C}$ (-13 to 158 $^{\circ}\text{F}$).
Storage: -40 to 85 $^{\circ}\text{C}$ (-40 to 185 $^{\circ}\text{F}$).

Relative Humidity

5 to 95%.

Power Requirements

10 to 36V DC. 120mA @ 24V. 200mA @ 15V.

Isolation (optical)

3-way (input/output/power).
Input circuits share a common.
1500V AC peak or 250V AC (354V DC) continuous.

Radiated Field Immunity (RFI)

EN61000-4-3, EN50082-1.

Electromagnetic Field Immunity (EMI)

Less than $\pm 0.25\%$ of output span effect under the influence of electromagnetic fields from switching solenoids, commutator motors, and drill motors.

Electrical Fast Transient (EFT)

EN61000-4-4, EN50082-1.

Surge Withstanding Capability (SWC)

EN61000-4-5, EN50082-1.

Electrostatic Discharge (ESD)

EN61000-4-2, EN50082-1.

Radiated Emissions

EN50081-1 for Class B equipment.

Approvals

UL listed
cUL listed
Hazardous Loc.: Class I; Division 2; Groups A, B, C, D.

■ Configuration

Software Configuration

Units are fully programmable via the Windows XP/Vista/7 IntelliPack Configuration Program. Configuration downloads from PC through EIA232 serial port using Acromag 800C-SIP kit.

LED Indicators

LEDs indicate power and status.

■ Physical

Enclosure

Case: Self-extinguishing NYLON type 6.6 polyamide thermoplastic UL94 V-2 NEMA Type 1 enclosure.

Connectors (Removable Terminal Blocks)

Wire Range: AWG #14-22 (AWG #12 stranded only).

Printed Circuit Boards

Military grade FR-4 epoxy glass circuit board.

Dimensions

1.05W x 4.68H x 4.35D inches.
26.7W x 118.9H x 110.5D millimeters.

Shipping Weight

1 pound (0.45 Kg) packed.

■ Ordering Information

IMPORTANT! All IntelliPack units require initial software configuration (order 800C-SIP). See Note 1 below.

892M-0500

Dual input computation module with single output.

894M-0500

Quad input computation module with single output.

5020-350

AC current sensor. Required for AC inputs.

800C-SIP

Software Interface Package.
Only one kit is required for all IntelliPack models. See diagram on Page 83 for included parts.

4001-095

USB-to-Serial adapter

PSSR-VD24

Power supply (24V DC, 2.1A)

TBK-802

Optional terminal block kit, barrier strip style, 4 pcs

TBK-502

Optional terminal block kit, spring clamp style, 4 pcs

NOTE 1: To order factory configuration, call Acromag for a configuration form which must accompany your order. Also, append "-C" to model number (example: 892M-0500-C). 800C-SIP kit is still recommended!



Optional terminal blocks: barrier strip (left) and spring clamp (right). Cage clamp terminal is standard.



Dimensions

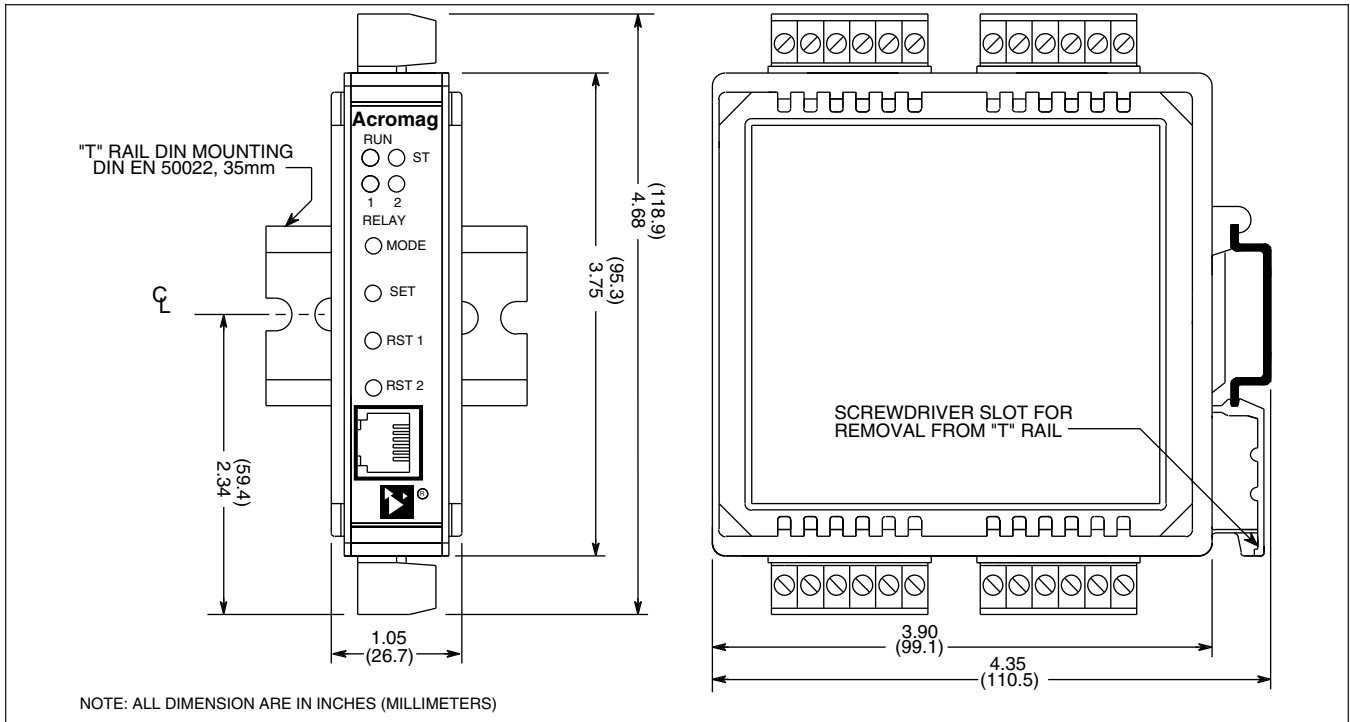



Accessories

Terminal Blocks



Barrier strip (left) and spring clamp (right).

Ordering Information

See individual I/O modules for compatibility.

Barrier Strip Terminal Blocks

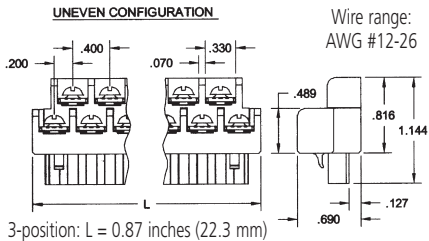
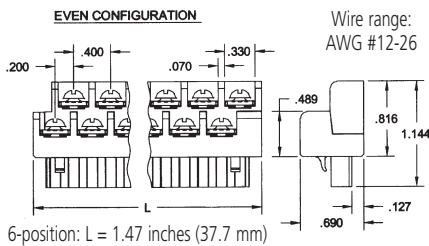

TBK-B01

Terminal block kit, two 6-position pieces

TBK-B02

Terminal block kit, four 6-position pieces

TBK-B03

Terminal block kit, one 3-position and three 6-position pieces

Spring Clamp Terminal Blocks

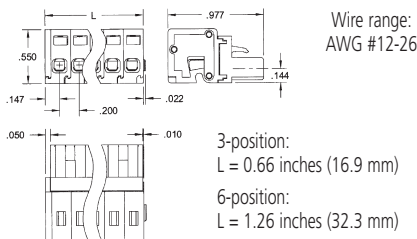

TBK-S01

Terminal block kit, two 6-position pieces

TBK-S02

Terminal block kit, four 6-position pieces

TBK-S03

Terminal block kit, one 3-position and three 6-position pieces

Mounting Hardware



DIN-Rail Mounting

For your convenience, Acromag offers several mounting accessories to simplify your system installation. Our 19" rack-mount kit provides a clean solution for mounting your I/O modules and a power supply. Or you can buy precut DIN rail strips for mounting on any flat surface.

Ordering Information

20RM-16-DIN: 19" rack-mount kit with DIN rail.

DIN RAIL 3.0 DIN RAIL 16.7

DIN rail strip, Type T, 3 inches (75mm) or 16.7 inches (425mm)

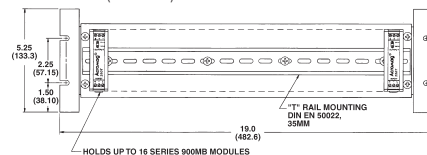

Power Supplies



50W Supply

Input Power Requirement

85 to 264V AC or 105 to 370V DC

Output

24V DC, 2.1A (50W)

Ordering Information

P55R-VD24: Universal 50W power supply

USB to Serial Adapter



Data Rate: Up to 115.2Kbps

RoHS-compliant

PC Requirements:

Windows® 7 and newer

Ordering Information

4001-095: USB-to-Serial adapter

AC Current Sensor

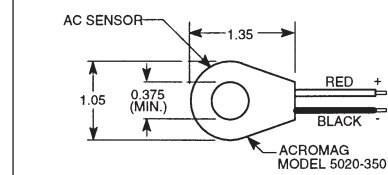

Ordering Information

5020-350: AC current sensor



Math/Computation



890M Units

Model Types

- **892M:** Dual DC voltage/current input with universal DC voltage/current output
- **894M:** Quad DC voltage/current input with universal DC voltage/current output
- **895M:** Single DC voltage/current input with frequency/pulse output
- **896M:** Dual DC voltage/current input with frequency/pulse output

Functions

32-bit floating point math processing ensures precise computing for highly accurate output.

- Add, subtract, multiply, divide
- Square root
- Exponential (e^n) and power (X^n)
- Logarithmic (natural and base 10)
- Sine, cosine, tangent, and inverse
- Absolute value
- Minimum/maximum
- Conditional arguments (if, then, else, and, or, >, <, <>, =, <=, >=)
- Input scaling
- High/low signal selector or discriminator
- Track and hold

DC to DC Conversion: 892/894M Math Modules

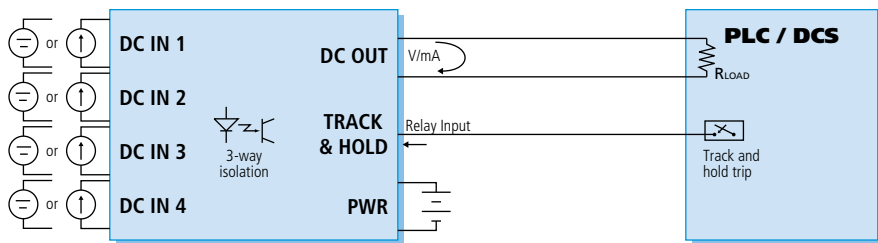

DC to Frequency Conversion: 895/896M Math Modules

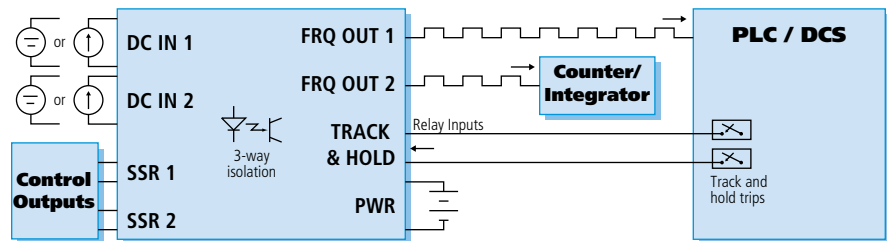

Description

IntelliPack math modules perform complex mathematical computations and convert DC input signals to scaled DC or frequency outputs. They are ideal for isolating and interfacing analog signals to a PLC or controller as a voltage, current, or a pulsed input. Typical applications include calculating a sum, delta's, average, flow rate, volume, weight, power, and other scaled or computed variables.

Math modules are available with either DC voltage/current output or frequency/pulse-width modulated output. The frequency output models also provide two solid-state relays for control or alarm functions. Each output (DC, frequency, and relay channels) is controlled by a unique, user-defined equation. On relay output channels, zero/nonzero equation results and true/false conditions control the on/off state.

Frequency output models are ideal for integrator/totalizer applications. They support ultra-low frequency pulses as slow as 10 cph. And, adjustable zero dropout levels apply a minimum input threshold to filter noise and unwanted pulses.

The math/computation equations are entered into the IntelliPack configuration software in a freeform format, the same as in most popular spreadsheet programs. A simulator screen provides instant feedback to test equations and see the output response before actual installation.

Special Features

- Universal DC analog I/O ranges provide flexibility for changing application requirements.
- Individual channel input/output scaling displays signal values in engineering units.
- Track and hold function enables easy identification of critical events and their corresponding signal values.
- 200-character equation fields (50-char. max. on 895/896M) support complex transfer functions.
- Software simulation feature allows off-line testing of equations to quickly check output signal response for a variety of conditions.
- Excitation supply for two 2-wire transmitters provides 15V DC @ 48mA to eliminate need for additional power supplies. 892/894M only.
- Diagnostic LEDs provide quick, visual indication of an out-of-range input value.

Frequency output models (895/896M) only

- Pulse output supports integrator and totalizer applications using an external counter to calculate flow, volume, weight, power, etc.
- Pulse-width modulation capability allows the user to vary the output signal's pulse width on a user-defined carrier frequency.
- Solid-state relays provide on/off control or local alarms with failsafe/ nonfailsafe capability.



Input Connections

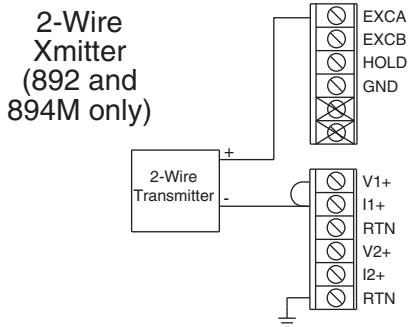
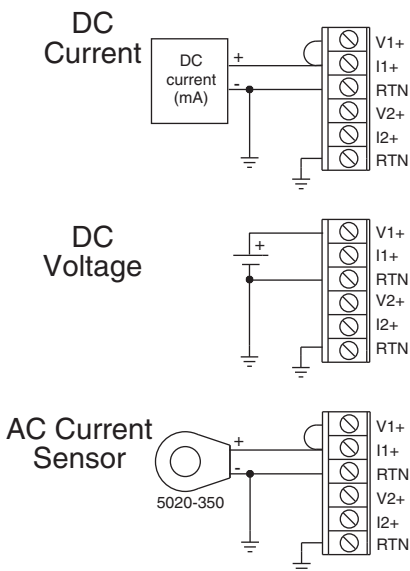

892/894M DC Output Math Module

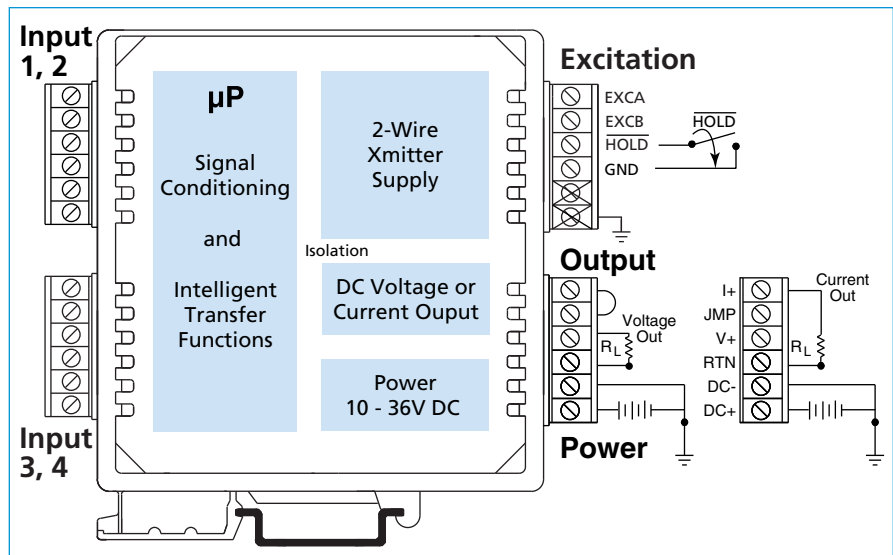

895/896M Frequency Output Math Module

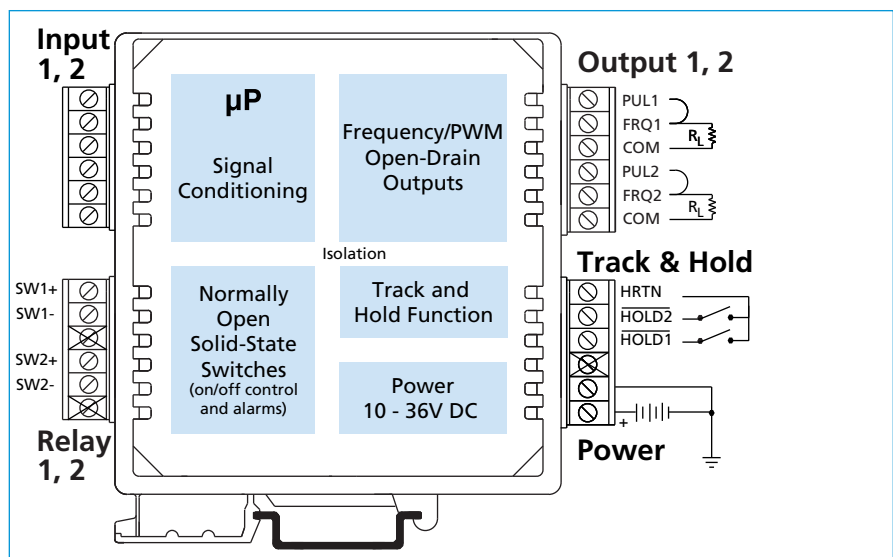

IntelliPack Features

- Advanced microcontroller has integrated, downloadable flash memory and EEPROM for intelligent signal processing.
- Windows 95/98/ME/NT/XP/2000 software configuration speeds setup and replacement.
- Plug-in terminal blocks make module installation and removal easy.
- Built-in self-diagnostic routines operate upon power-up and during operation for easy maintenance and troubleshooting.
- 3-way optical isolation separates inputs, outputs, and power from each other.
- EMC compliant. Ruggedized circuitry meets directives to provide increased transient immunity and low emissions.
- Wide ambient temperature range ensures reliable performance from -25 to 70°C.
- Wide DC supply range has diode-coupled reverse polarity protection.