

Check valve type RK, RB

Product documentation



Screw-in valve

Operating pressure p_{\max} :

700 bar

Flow rate Q_{\max} :

620 l/min



Table of Contents

1	Check valve type RK, RB overview.....	4
2	Available versions.....	5
2.1	Screw-in valve.....	5
2.1.1	Basic type and size.....	6
2.1.2	Seals.....	7
2.2	Housing version for pipe installation.....	8
2.2.1	Housing version.....	8
3	Parameters.....	10
3.1	General data.....	10
3.2	Weight.....	11
3.3	Characteristic lines.....	12
4	Dimensions.....	14
4.1	Screw-in valve.....	14
4.2	Housing version.....	17
4.3	Creating the mounting hole.....	20
5	Installation, operation and maintenance information.....	25
5.1	Intended use.....	25
5.2	Assembly information.....	25
5.2.1	Securing screw-in valves and fittings.....	25
5.2.2	Creating the mounting hole.....	25
5.2.3	Assembly tool for type RK.....	26
5.3	Operating instructions.....	27
5.4	Maintenance information.....	27

1**Check valve type RK, RB overview**

Check valves with hydraulic release are a type of check valve. They block the oil flow in one direction and open in the opposite direction. In the closed state they have zero leakage.

The check valve type RK and RB can be screwed in.

The spring-loaded ball check valve type RK and RB is very robust and insensitive to soiling.

Features and advantages

- Operating pressures up to 700 bar
- Simple fastening holes
- Robust and dirt resistance
- Type RK, RB also available with different pre-load pressures

Intended applications

- General hydraulic systems
- Hydraulic pre-loading



Screw-in valve Type RB

2 Available versions

2.1 Screw-in valve

Circuit symbol

RK



screwed in in locking direction

RB



screwed in in free flow direction

Ordering examples

RB 2			-PYD
RK 1 UNF			
RK 2	-5	-G	

2.1.1 "Basic type and size" (under RB 2)
 2.1.1 "Basic type and size" (under RK 1 UNF)
 2.1.1 "Basic type and size" (under RK 2)
 Opening pressure (high) (under -5)
 2.1.1 "Basic type and size" (under -G)
 2.1.2 "Seals" (under -PYD)
 2.2.1 "Housing version" (under -G)

2.1.1 Basic type and size

RK

Type	Flow rate Q _{max} (l/min)	Pressure p _{max} (bar)	Thread	Opening pressure (bar)
Imperial thread, low opening pressure				
RK 0	10	700	G 1/8 A	0.11
RK 1	20	700	G 1/4 A	0.1
RK 2	50	700	G 3/8 A	0.11
RK 3	80	500	G 1/2 A	0.1
RK 4	120	500	G 3/4 A	0.1
RK 5	240	500	G 1 A	0.1
RK 6	400	420	G 1 1/4 A	0.1
RK 7	620	420	G 1 1/2 A	0.1
Imperial thread, high opening pressure				
RK 0-0.4	10	700	G 1/8 A	0.4
RK 1-...	20	700	G 1/4 A	0.5; 1; 2; 3; 4; 5; 6; 7; 8; 10
RK 2-...	50	700	G 3/8 A	1; 2; 3; 4; 5; 6
RK 3-...	80	500	G 1/2 A	1; 2; 3; 4; 5
RK 4-...	120	500	G 3/4 A	0.5; 1; 2; 3; 4; 5; 6; 7; 8; 10
RK 5-...	240	420	G 1 A	1; 2; 3; 5; 8; 10
RK 6-...	400	420	G 1 1/4 A	0.1; 0.5; 1; 2; 3; 4; 5; 6; 8; 10
Metric thread, low opening pressure				
RK 08	5	700	M8x1	0.2
RK 14	20	700	M14x1.5	0.1
RK 16	20	700	M16x1.5	0.1
RK 28	50	700	M18x1.5	0.11
RK 32	80	500	M22x1.5	0.1
RK 47	120	500	M27x2	0.1
Metric thread, high opening pressure				
RK 08-0.45	5	700	M8x1	0.45
RK 14-...	20	700	M14x1.5	0.5; 1; 2; 3; 4; 5; 6; 7; 8
RK 28-...	50	700	M18x1.5	1; 2; 3; 4; 5; 6
RK 32-...	80	500	M22x1.5	1; 2; 3; 4; 5
RK 47-...	120	500	M27x2	0.5; 1; 2; 3; 4; 5; 6; 7; 8; 10
RK 62-...	400	420	M42x2	0.1; 0.5; 1; 2; 3; 4; 5; 6; 8; 10
UNF thread, low opening pressure				
RK 08 UNF	5	630	5/16-24 UNF	0.2
RK 0 UNF	10	630	7/16-20 UNF	0.11
RK 1 UNF	20	630	9/16-18 UNF	0.18
RK 2 UNF	50	630	3/4-16 UNF	0.2
RK 3 UNF	80	420	7/8-14 UNF	0.25
RK 4 UN	120	420	1 1/16-12 UN	0.1

RB

Type	Flow rate Q _{max} (l/min)	Pressure p _{max} (bar)	Thread	Opening pressure (bar)
Imperial thread, low opening pressure				
RB 0	10	700	G 1/8 A	0.13
RB 1	20	700	G 1/4 A	0.09
RB 2	50	700	G 3/8 A	0.12
RB 3	80	500	G 1/2 A	0.11
RB 4	120	500	G 3/4 A	0.1
Imperial thread, high opening pressure				
RB 1-0.9	20	700	G 1/4 A	0.9
Metric thread, low opening pressure				
RB 07	5	700	M8x0.75	0.2
RB 08	5	700	M8x1	0.2
RB 14	20	700	M14x1.5	0.09
RB 28	50	700	M18x1.5	0.12
RB 32	80	500	M22x1.5	0.11
RB 47	120	500	M27x2	0.1
Metric thread, high opening pressure				
RB 08-0.45	5	700	M8x1	0.45
UNF thread, low opening pressure				
RB 08 UNF	5	630	5/16-24 UNF	0.2
RB 0 UNF	10	630	7/16-20 UNF	0.13
RB 1 UNF	20	630	9/16-18 UNF	0.09
RB 2 UNF	50	630	3/4-16 UNF	0.12
RB 3 UNF	80	420	7/8-14 UNF	0.11
RB 4 UN	120	420	1 1/16-12 UN	0.1

! NOTICE

- Thread equivalent ISO 228-1, DIN 13 T6 (metric) or SAE J 514 (UNF).
- For RK.-... types, one of the opening pressures listed must be specified.

2.1.2 Seals

Coding	Description
without coding	NBR standard
AT	EPDM seal
PYD	FKM seal
without O-ring	No seal

! NOTICE

- AT and PYD seals for E & F housing versions on request.
- When using the version with no seal, the same level of sealing cannot be assumed as with an O-ring, as it depends on the screw-in situation.

2.2 Housing version for pipe installation

Ordering examples

RB 2		-G
RK 2	-5	-E

2.2.1 "Housing version"

Opening pressure (high) 2.1.1 "Basic type and size"

2.1.1 "Basic type and size"

2.2.1 Housing version

Imperial thread

Type	Pressure p_{max} (bar)	Coding					
		RK, RB		RK		RB	
		G	G-JIS	E	E-JIS	F	F-JIS
RK							
RB							

Imperial thread, low opening pressure

Type	Pressure p_{max} (bar)	G	G-JIS	E	E-JIS	F	F-JIS
RK 0, RB 0	700	●		●		●	
RK 1, RB 1	700	●	●	●	●	●	●
RK 2, RB 2	700	●	●	●	●	●	●
RK 3, RB 3	500	●	●	●	●	●	●
RK 4, RB 4	500	●	●	●	●	●	●
RK 5	420	●		●			
RK 6	420	●		●			
RK 7	320	●		●			

Imperial thread, high opening pressure

Type	Pressure p_{max} (bar)	G	G-JIS	E	E-JIS	F	F-JIS
RK 0-0.4	700	●		●			
RK 1-..., RB 1-0.9	700	●	●	●	●	●	●
RK 2-...	700	●	●	●	●		
RK 3-...	500	●	●	●	●		
RK 4-...	500	●	●	●	●		
RK 5-...	420	●		●			
RK 6-...	420	●		●			

Metric thread

Type	Coding					
	RK, RB		RK		RB	
	G	G-JIS	E	E-JIS	F	E-JIS
RK	F					
RB	B					

Metric thread, low opening pressure

RK 08, RB 07, RB 08						
RK 14, RB 14	●		●		●	
RK 16	●		●			
RK 28, RB 28	●		●		●	
RK 32, RB 32	●		●		●	
RK 47, RB 47	●		●		●	

Metric thread, high opening pressure

RK 08-0.45 RB 08-0.45						
RK 14-...	●		●			
RK 28-...	●		●			
RK 32-...	●		●			
RK 47-...	●		●			
RK 62-...	●		●			

! NOTICE
For the housing version, note p_{max} of the fitting!

! NOTICE
The connection fittings used by the customer are subject to the installation specifications (tightening torque etc.) provided by the fitting manufacturer.

3.1 General data

Designation	Check valve
Design	Ball seated valve
Model	Screw-in valve, housing version
Material	Ball made of rolling bearing steel Steel; hardened, ground functional inner parts
Surface protection	Single valves blank (short-term corrosion protection), housing version ZnNi
Installation position	As desired
Hydraulic fluid	Hydraulic fluid, according to DIN 51524 Parts 1 to 3; ISO VG 10 to 68 according to DIN ISO 3448 Viscosity range: 4 - 1500 mm ² /s Optimal operating range: approx. 10 - 500 mm ² /s Also suitable for biologically degradable hydraulic fluids type HEPG (polyalkylene glycol) and HEES (synthetic ester) at operating temperatures up to approx. +70°C.
Cleanliness level	ISO 4406 <u>21/18/15...19/17/13</u>
Temperatures	Environment: approx. -40 to +80 °C, hydraulic fluid: -25 to +80 °C, pay attention to the viscosity range. Start temperature: down to -40 °C is permissible (take account of the start viscosities!), as long as the steady-state temperature is at least 20 K higher during subsequent operation. Biologically degradable hydraulic fluids: note manufacturer specifications. With consideration for the seal compatibility, not above +70°C.

3.2 Weight

Screw-in valve	Type			
	Type	G	E	F
	RK 0, RK 0 UNF, RK 0-0.4, RK 08			
		= 3 g		
	RK 1, RK 1 UNF, RK 14, RK 16			
		= 5 g		
	RK 1-...			
		= 30 g		
	RK 2, RK 2 UNF, RK 28			
		= 12 g		
	RK 2-...			
		= 40 g		
	RK 3, RK 3 UNF, RK 32			
		= 20 g		
	RK 3-...			
		= 60 g		
	RK 4, RK 4 UN, RK 47			
		= 45 g		
	RK 5			
		= 85 g		
	RK 5-...			
		= 150 g		
	RK 6			
		= 200 g		
	RK 6-..., RK 62-...			
		= 300 g		
	RK 7			
		= 280 g		
	RB 0, RB 0 UNF, RB 07, RB 08, RB 08 UNF, RB 08-0.45			
		= 3 g		
	RB 1, RB 1-0,9, RB 1 UNF, RB 1-14			
		= 5 g		
	RB 2, RB 2 UNF, RB 28			
		= 12 g		
	RB 3, RB 3 UNF, RB 32			
		= 21 g		
	RB 4, RB 4 UN, RB 47			
		= 45 g		
Housing version	Type	G	E	F
	RK 0, RB 0	30 g	30 g	30 g
	RK 1, RB 1	75 g	60 g	60 g
	RK 2, RB 2	105 g	85 g	85 g
	RK 3, RB 3	160 g	140 g	140 g
	RK 4, RB 4	340 g	300 g	300 g
	RK 5	770 g	650 g	--
	RK 6	1000 g	950 g	--
	RK 7	1650 g	1400 g	--

3.3 Characteristic lines

Viscosity of the hydraulic fluid approx. 50 mm²/s

RK

RK 08, RK 0, RK 1

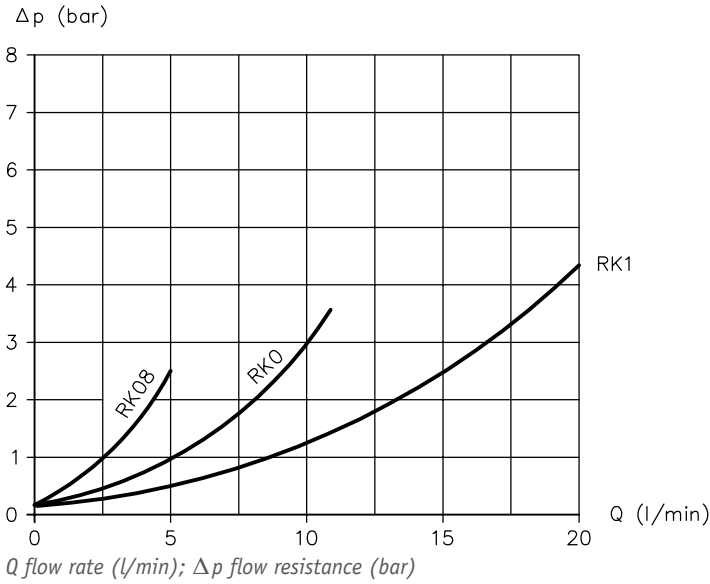

RK 2 - RK 7

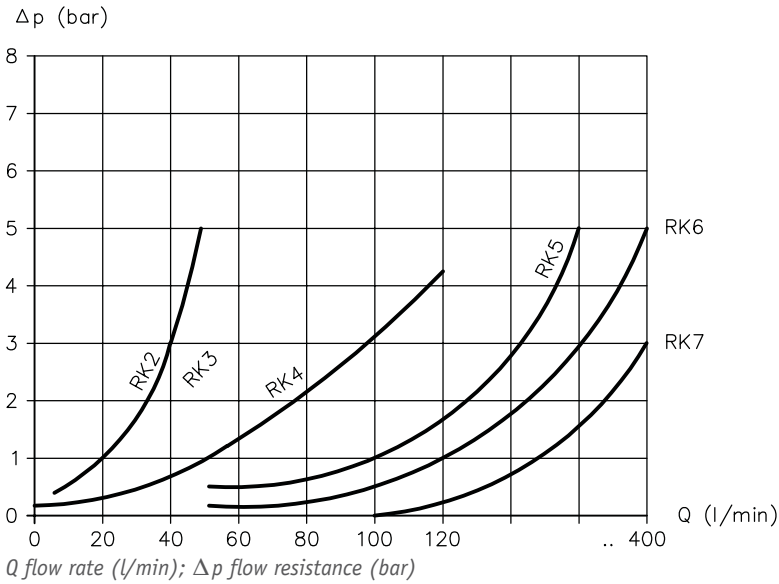

RB

RB 07, RB 08, RB 0, RB 1-0.9, RB 1

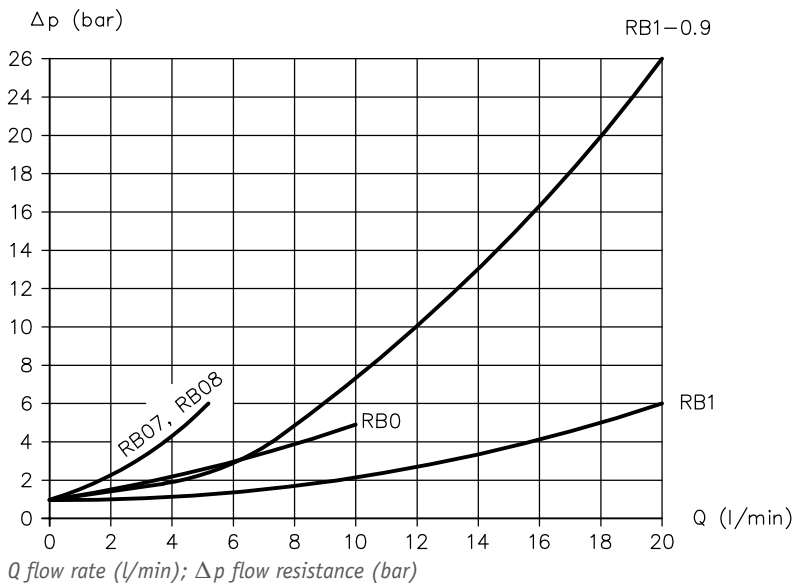

RB 2 - RB 4

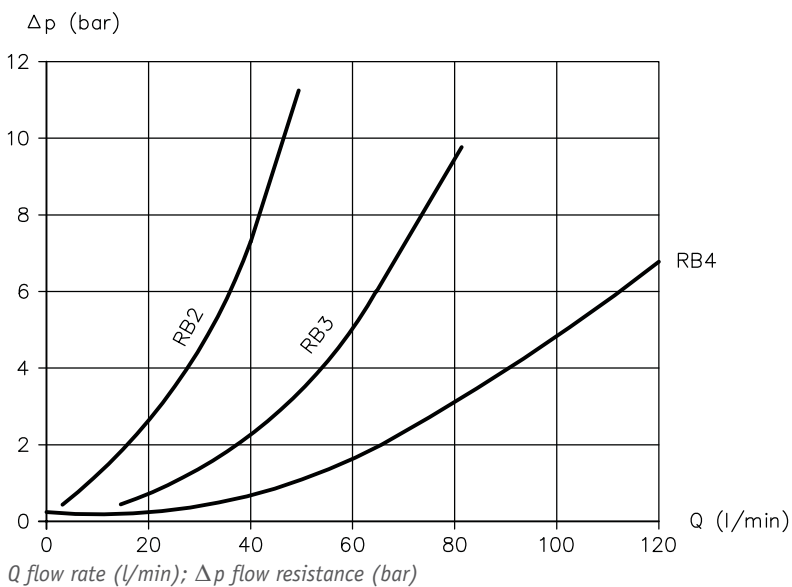

NOTICE

Th characteristic lines are reference values and are subject to fluctuations, which can occur due to component and spring tolerances.

4 Dimensions

All dimensions in mm, subject to change.

4.1 Screw-in valve

RK ...

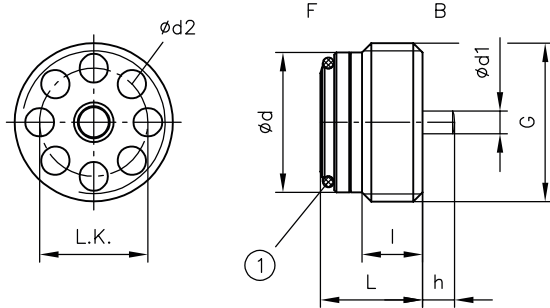

1 O-ring

RK. - ...

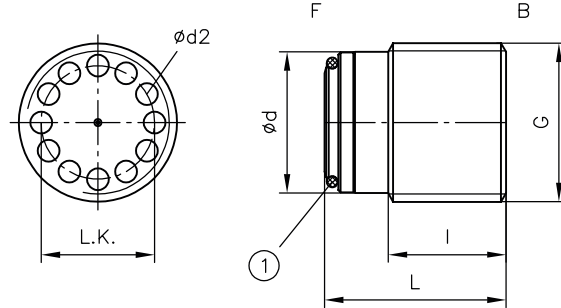

1 O-ring

Type	G	L	l	$\varnothing d$	$\varnothing d1$	$\varnothing d2$	h	L.K.	O-ring NBR 90 Sh	Tightening torque M_A (Nm) *
Imperial thread, low opening pressure										
RK 0	G 1/8 A	7.2	3.8	8.6	2	1.5	1.3	6.9	6x1	8
RK 1	G 1/4 A	9	4.5	11.5	2.6	2.2	1.5	8.9	9x1	15
RK 2	G 3/8 A	11.2	6.5	15	3.4	3	2.5	11.1	11x1.5	20
RK 3	G 1/2 A	13.5	8	18.5	4.3	3.8	3	14.3	14x1.5	40
RK 4	G 3/4 A	17.5	10	24	5.8	4.6	3.5	18.6	18.77x1.78	80
RK 5	G 1 A	22	12.5	30	7	4.5	4.5	23	23.47x2.62	200
RK 6	G 1 1/4 A	27.5	16.5	38.8	8.2	5.8	5	30	29.75x3.53	250
RK 7	G 1 1/2 A	35	20	44.5	10	6.8	5.5	35.5	36x3	300
Imperial thread, high opening pressure										
RK 0-...	G 1/8 A	7.3	3.8	8.6	2	1.5	0.9	6.9	6x1	8
RK 1-...	G 1/4 A	16	7.5	11.45	--	1.8	--	9-0.1	9x1	15
RK 2-...	G 3/8 A	20	12.5	15	--	2	--	12.1	11x1.5	20
RK 3-...	G 1/2 A	24	15.5	18.7	--	2.9	--	15-0.1	14x1.5	40
RK 4-...	G 3/4 A	30	14.4	24	--	3.5	--	19	18.77x1.78	80
RK 5-...	G 1 A	38	22	30	--	4.5	--	23	23.47x2.62	200
RK 6-...	G 1 1/4 A	55	24	38.8	--	5.5	--	30.5	29.75x3.53	250

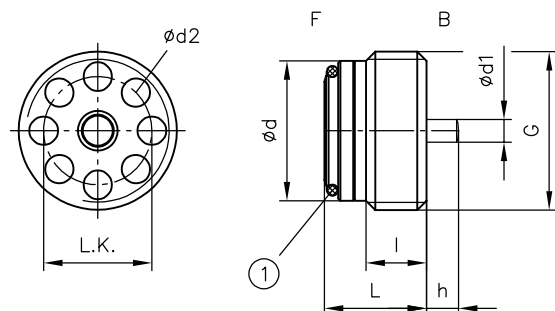
RK ...

1 O-ring

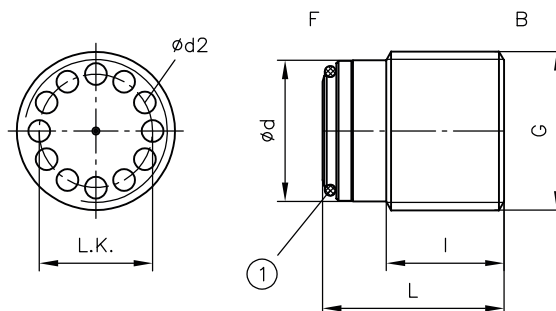
RK. - ...

1 O-ring

Type	G	L	l	$\varnothing d$	$\varnothing d1$	$\varnothing d2$	h	L.K.	O-ring NBR 90 Sh	Tightening torque M_A (Nm) *
------	---	---	---	-----------------	------------------	------------------	---	------	---------------------	-----------------------------------

Metric thread, low opening pressure

RK 08	M8x1	5.5	3.2	6.7	1.4	1.3	0.8	4.8	5x0.8 (70 Sh)	6
RK 14	M14x1.5	9	4.5	11.5	2.6	2.2	1.5	8.9	9x1	15
RK 16	M16x1.5	9	4.5	14	2.6	2.8	1.5	11	10x1.5	15
RK 28	M18x1.5	11.2	6.5	15	3.4	3	2.5	11.1	11x1.5	20
RK 32	M22x1.5	13.5	8	18.5	4.3	3.8	3	14.3	14x1.5	40
RK 47	M27x2	17.5	10	24	5.8	4.6	3.5	18.6	18.77x1.78	80

Metric thread, high opening pressure

RK 08-0.45	M8x1	5.5	3.2	6.7	1.4	1.3	0.8	4.8	5x0.8 (70 Sh)	6
RK 14-...	M14x1.5	16	7.5	11.45	--	1.8	--	9-0.1	9x1	15
RK 28-...	M18x1.5	20	12.5	15	--	2	--	12.1	11x1.5	20
RK 32-...	M22x1.5	24	15.5	18.7	--	2.9	--	15-0.1	14x1.5	40
RK 47-...	M27x2	30	14.4	24	--	3.5	--	19	18.77x1.78	80
RK 62-...	M42x2	55	24	38.8	--	5.5	--	30.5	29.75x3.53	250

UNF thread, low opening pressure

RK 08 UNF	5/16-24 UNF-2A	5.5	3.2	6.7	1.4	1.3	0.8	4.8	5x0.8 (70 Sh)	6
RK 0 UNF	7/16-20 UNF-2A	7.3	3.8	8.6	2	1.5	1.3	6.9	6x1	8
RK 1 UNF	9/16-18 UNF-2A	9	4.5	11.5	2.6	2.2	1.5	8.9	10x1.5	15
RK 2 UNF	3/4-16 UNF-2A	11.5	6.5	15	3.4	3	2.5	11.1	11x1.5	20
RK 3 UNF	7/8-14 UNF-2A	13.5	8	18.5	4.3	3.8	3	14.3	14x1.5	40
RK 4 UN	1 1/16-12 UN-2A	17.5	10	24	5.8	4.6	3.5	18.6	18.77x1.78	80

RB ...

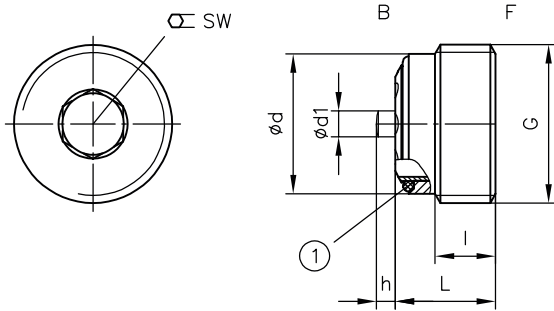

SW = Width across flats

1 O-ring

Type	G	L	l	$\varnothing d$	$\varnothing d_1$	h	SW	O-ring NBR 90 Sh	Tightening torque M_A (Nm) *
Imperial thread, low opening pressure									
RB 0	G 1/8 A	7.9	4.5	8.6	1.7	1.3	5	6x1	8
RB 1	G 1/4 A	10.3	5.5	11.6	2	1.5	7	9x1	15
RB 2	G 3/8 A	11.7	7	15	3	2	6	11x1.5	20
RB 3	G 1/2 A	13.2	7.5	18.5	3.4	2.5	8	14x1.5	40
RB 4	G 3/4 A	17.1	10	24	5.8	3.8	12	18.77x1.78	80
Imperial thread, high opening pressure									
RB 1-0.9	G 1/4 A	10.3	5.5	11.6	2	0.6	7	9x1	15
Metric thread, low opening pressure									
RB 07	M8x0.75	6.6	3.5	6.9	1.4	0.8	3	5x0.8 (70 Sh)	3
RB 08	M8x1	6.5	3.5	6.9	1.4	0.8	4	5x0.8 (70 Sh)	6
RB 14	M14x1.5	10.3	5	11.6	2.2	1.3	7	9x1	15
RB 28	M18x1.5	11.7	7	15	3	2	6	11x1.5	20
RB 32	M22x1.5	13.2	7.5	18.5	3.4	2.5	8	14x1.5	40
RB 47	M27x2	17.1	10	24	5.8	3.8	12	18.77x1.78	80
Metric thread, high opening pressure									
RB 08-0.45	M8x1	6.5	3.5	6.9	1.4	0.8	4	5x0.8 (70 Sh)	6
UNF thread, low opening pressure									
RB 08 UNF	5/16-24 UNF-2A	6.5	3.5	6.7	1.4	0.8	5/32"	5x0.8 (70 Sh)	6
RB 0 UNF	7/16-20 UNF-2A	7.9	4.5	9.4	1.7	1.3	3/16"	6x1	8
RB 1 UNF	9/16-18 UNF-2A	10.3	5	12.3	2.2	1.3	1/4"	9x1	15
RB 2 UNF	3/4-16 UNF-2A	11.7	7	16.8	3	2	1/4"	11x1.5	20
RB 3 UNF	7/8-14 UNF-2A	13.2	7.5	19.9	3.4	2.5	5/16"	14x1.5	40
RB 4 UN	1 1/16-12 UN-2A	17.1	10	23.9	5.8	3.8	1/2"	18.77x1.78	80

NOTICE

* Tightening torques validated using steel / steel combination.

4.2 Housing version

RK ... G, G-JIS
RB ... G, G-JIS

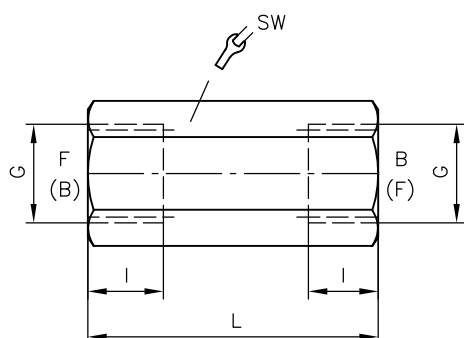

SW = Width across flats

RK ... E, E-JIS
RB ... F, F-JIS

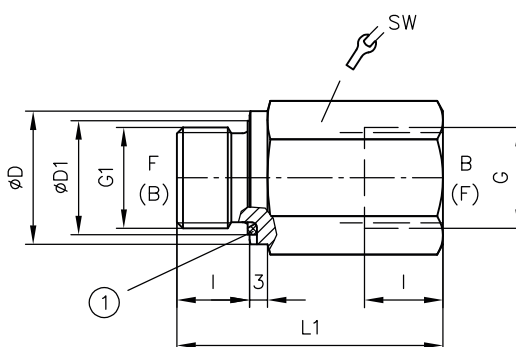

1 Thread seal

Type	G	G1	$\varnothing D$	$\varnothing D1$	L	L1	l	SW	Tightening torque (Nm)	Thread seal
Imperial thread, low opening pressure										
RK 0 RB 0	G 1/8	G 1/8 A	14	12.5	30	28	8	14	20	Cutting edge
RK 1 RB 1 RB 1-0.9	G 1/4	G 1/4 A	19	--	46	43	12	19	40	Fitting seal
	G 1/4-JIS	G 1/4 A-JIS	19	--	58	47	12	19	40	O-ring 10.80x2.40
RK 2 RB 2	G 3/8	G 3/8 A	22	20.5	50	44	12	22	80	Cutting edge
	G 3/8-JIS	G 3/8 A-JIS	24	--	58	58	12	24	80	O-ring 13.80x2.40
RK 3 RB 3	G 1/2	G 1/2 A	26	24	56	52	14	27	150	Cutting edge
	G 1/2-JIS	G 1/2 A-JIS	27	--	72	72	16	27	150	O-ring 17.80x2.40
RK 4 RB 4	G 3/4	G 3/4 A	36	30	65	60	16	36	180	Fitting seal
	G 3/4-JIS	G 3/4 A-JIS	41	--	85	85	17	41	180	O-ring 23.70x3.50
RK 5	G 1	G 1 A	39.9	--	80	72	18	46	200	Fitting seal
RK 6	G 1 1/4	G 1 1/4 A	49.9	--	98	85	20	55	250	Fitting seal
RK 7	G 1 1/2	G 1 1/2 A	54.9	--	105	95	22	60	300	Fitting seal

NOTICE

The connection fittings used by the customer are subject to the installation specifications (tightening torque etc.) provided by the fitting manufacturer.

RK ... G, G-JIS
RB ... G, G-JIS

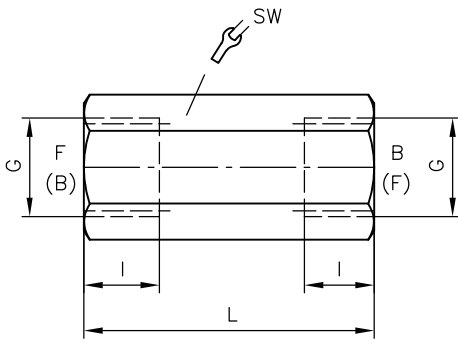

SW = Width across flats

RK ... E, E-JIS
RB ... F, F-JIS

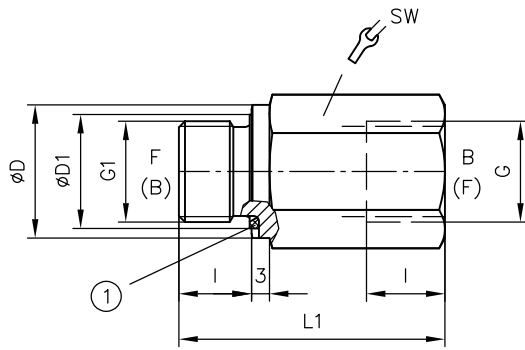

1 Thread seal

Type	G	G1	ØD	ØD1	L	L1	l	SW	Tightening torque (Nm)	Thread seal
Imperial thread, high opening pressure										
RK 0-...	G 1/8	G 1/8 A	14	12.5	30	28	8	14	20	Cutting edge
RK 1-...	G 1/4	G 1/4 A	19	--	55	50	12	19	40	Fitting seal
	G 1/4-JIS	G 1/4 A-JIS	19	--	58	47	12	19	40	O-ring 10.80x2.40
RK 2-...	G 3/8	G 3/8 A	22	20.5	60	60	15	22	80	Cutting edge
	G 3/8-JIS	G 3/8 A-JIS	24	--	58	58	12	24	80	O-ring 13.80x2.40
RK 3-...	G 1/2	G 1/2 A	27	25	68	63	14	27	150	Cutting edge
	G 1/2-JIS	G 1/2 A-JIS	27	--	72	72	16	27	150	O-ring 17.80x2.40
RK 4-...	G 3/4	G 3/4 A	32	30	82	80	16	36	180	Cutting edge
	G 3/4-JIS	G 3/4 A-JIS	41	--	85	85	17	41	180	O-ring 23.70x3.50
RK 5-...	G 1	G 1 A	39.9	--	100	88	18	46	200	Fitting seal
RK 6-...	G 1 1/4	G 1 1/4 A	49.9	--	125	120	20	55	250	Fitting seal

NOTICE

The connection fittings used by the customer are subject to the installation specifications (tightening torque etc.) provided by the fitting manufacturer.

RK ... G, G-JIS
RB ... G, G-JIS

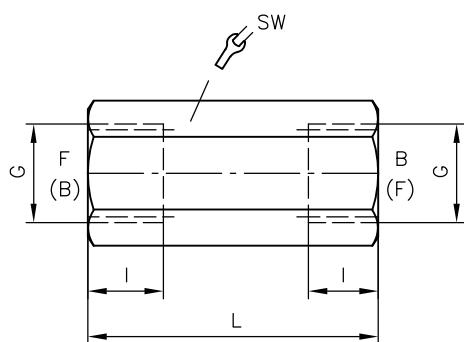

SW = Width across flats

RK ... E, E-JIS
RB ... F, F-JIS

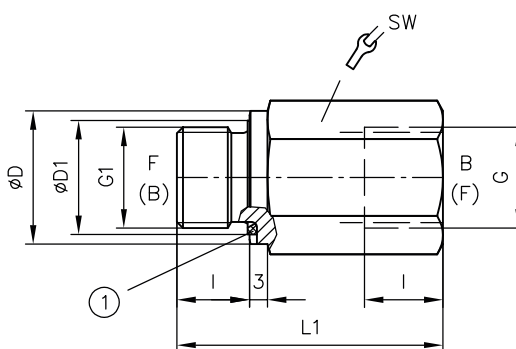

1 Thread seal

Type	G	G1	ØD	ØD1	L	L1	l	SW	Tightening torque (Nm)	Thread seal
Metric thread, low opening pressure										
RK 14 RB 14	M14x1.5	M14x1.5	19	--	46	42	12	19	40	Fitting seal
RK 16	M16x1.5	M16x1.5	21	20	50	44	12	22	80	Cutting edge
RK 28 RB 28	M18x1.5	M18x1.5	24	23	50	44	12	24	80	Cutting edge
RK 32 RB 32	M22x1.5	M22x1.5	26	24	56	52	14	30	150	Cutting edge
RK 47 RB 47	M27x2	M27x2	31.9	29.3	65	60	19.5	36	180	Fitting seal
Metric thread, high opening pressure										
RK 14-...	M14x1.5	M14x1.5	19	17	55	50	12	19	40	Cutting edge
RK 28-...	M18x1.5	M18x1.5	23	20.5	60	60	15	24	80	Cutting edge
RK 32-...	M22x1.5	M22x1.5	27	25	68	63	14	27	150	Cutting edge
RK 47-...	M27x2	M27x2	32	30	82	80	16	36	180	Cutting edge
RK 62-...	M42x2	M42x2	49.9	--	125	120	20	55	250	Fitting seal

NOTICE

The connection fittings used by the customer are subject to the installation specifications (tightening torque etc.) provided by the fitting manufacturer.

4.3 Creating the mounting hole

For external line connection using pipe screw connection

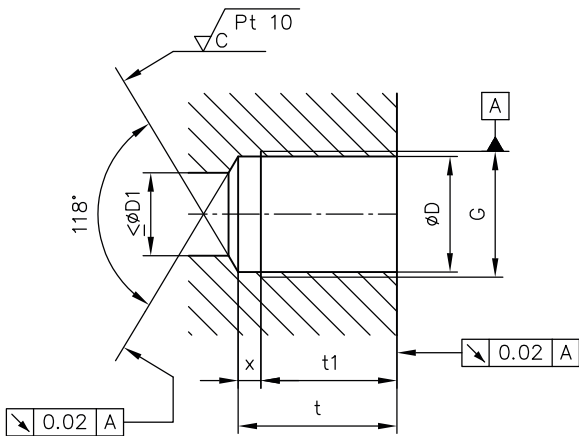

NOTICE
End of the thread X adhere rigorously. Dimension X may be smaller, but not larger.

General tolerances in accordance with DIN ISO 2768-mk-E

Type	G	ØD	ØD1	t	t1	x
Imperial thread, low opening pressure						
RK 0 RB 0	G 1/8	8.7 ^{+0.1} _{-0.05}	5	17	15	2
RK 1 RB 1 RB 1-1	G 1/4	11.8 ^{+0.08} _{-0.1}	8	23.5	20.5	3
RK 2 RB 2	G 3/8	15.25 ±0.1	9	26	23	3
RK 3 RB 3	G 1/2	19 ±0.1	12	30	26.5	3.5
RK 4 RB 4	G 3/4	24.5 ±0.1	16	37.5	33.5	4
RK 5	G 1	30.75 ±0.1	20	43.5	37.5	6
RK 6	G 1 1/4	39.25 ±0.1	23	51.5	45	6.5
RK 7	G 1 1/2	45.25 ±0.1	30	62	52	10
Imperial thread, high opening pressure						
RK 0-...	G 1/8	8.7 ^{+0.1} _{-0.05}	5	17	15	2
RK 1-...	G 1/4	11.8 ^{+0.08} _{-0.1}	8	36	31	5
RK 2-...	G 3/8	15.25 ±0.1	9	36	31	5
RK 3-...	G 1/2	19 ±0.1	12	46	41	5
RK 4-...	G 3/4	24.5 ±0.1	16	52	42	10
RK 5-...	G 1	30.75 ±0.1	20	60	50	10
RK 6-...	G 1 1/4	39.25 ±0.1	23	80	58	22

For internal conduits

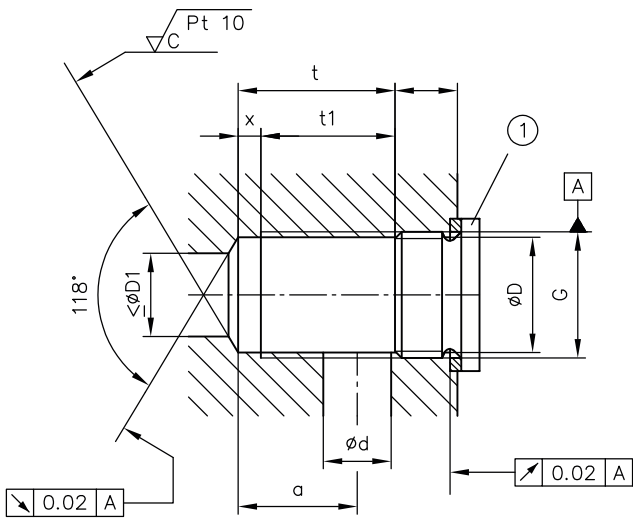

NOTICE
End of the thread X adhere rigorously. Dimension X may be smaller, but not larger.

General tolerances in accordance with DIN ISO 2768-mk-E

1 Example: Tapped plug DIN 908

Type	G	ØD	ØD1	Ød	t	t1	x	a
Imperial thread, low opening pressure								
RK 0 RB 0	G 1/8	8.7 ^{+0.1} _{-0.05}	5	5	12	10	2	9.5
RK 1 RB 1 RB 1-1	G 1/4	11.8 ^{+0.08} _{-0.1}	8	8	17	14	3	13
RK 2 RB 2	G 3/8	15.25 ±0.1	9	9	19	16	3	14.5
RK 3 RB 3	G 1/2	19 ±0.1	12	12	24	20.5	3.5	18
RK 4 RB 4	G 3/4	24.5 ±0.1	16	16	32	28	4	24
RK 5	G 1	30.75 ±0.1	20	20	40	34	6	30
RK 6	G 1 1/4	39.25 ±0.1	23	23	47.5	41	6.5	36
RK 7	G 1 1/2	45.25 ±0.1	30	30	62.5	52.5	10	47.5
Imperial thread, high opening pressure								
RK 0-...	G 1/8	8.7 ^{+0.1} _{-0.05}	5	5	12	10	2	9.5
RK 1-...	G 1/4	11.8 ^{+0.08} _{-0.1}	8	8	23	18	5	19
RK 2-...	G 3/8	15.25 ±0.1	9	9	27.5	22.5	5	23
RK 3-...	G 1/2	19 ±0.1	12	12	34.5	29.5	5	28.5
RK 4-...	G 3/4	24.5 ±0.1	16	16	44.5	34.5	10	36.5
RK 5-...	G 1	30.75 ±0.1	20	20	56	46	10	46
RK 6-...	G 1 1/4	39.25 ±0.1	23	23	80	58	22	65

NOTICE
End of the thread X adhere rigorously. Dimension X may be smaller, but not larger.

General tolerances in accordance with DIN ISO 2768-mk-E

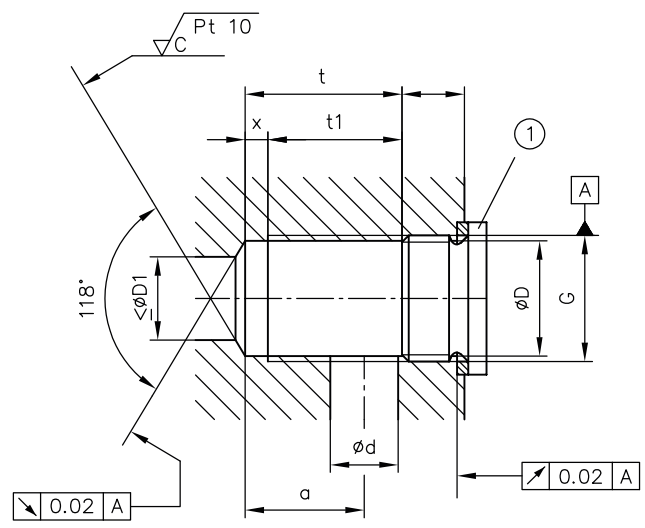

1 Example: Tapped plug DIN 908

Type	G	ØD	ØD1	Ød	t	t1	x	a
Metric thread, low opening pressure								
RB 07	M8x0,75	7.25 ±0.1	4.5	4.5	10.5	8.5	2	8.5
RK 08 RB 08	M8x1	7 ±0.1	4.5	4.5	10.5	8.5	2	8.5
RK 14 RB 14	M14x1,5	12.5 ±0.1	8	8	17	14	3	13
RK 16	M16x1,5	14.5 ±0.1	8	8	17	14	3	13
RK 28 RB 28	M18x1,5	16.5 ±0.1	9	9	19	16	3	14.5
RK 32 RB 32	M22x1,5	20.5 ±0.1	12	12	24	20.5	3,5	18
RK 47 RB 47	M27x2	25 ±0.1	16	16	32	28	4	24
Metric thread, high opening pressure								
RK 14-...	M14x1,5	12.5 ±0.1	8	8	21	16	5	18
RK 28-...	M18x1,5	16.5 ±0.1	9	9	27.5	22.5	5	23
RK 32-...	M22x1,5	20.5 ±0.1	12	12	34.5	29.5	5	28.5
RK 47-...	M27x2	25 ±0.1	16	16	44.5	34.5	10	36.5
RK 62-...	M42x2	40 ±0.1	23	23	80	58	22	65

NOTICE
End of the thread X adhere rigorously. Dimension X may be smaller, but not larger.

General tolerances in accordance with DIN ISO 2768-mk-E

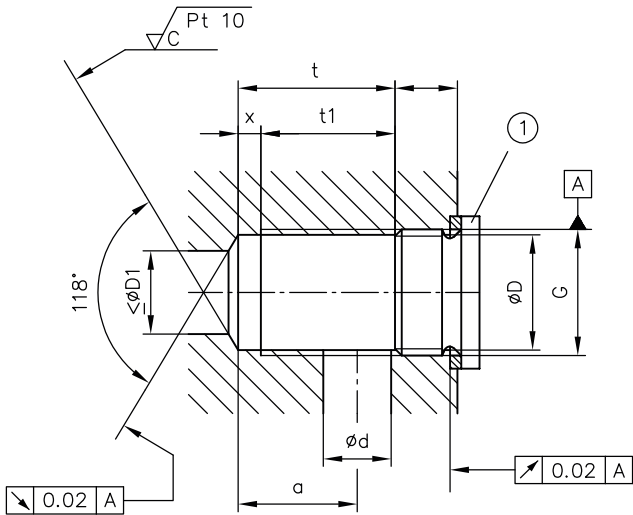

1 Example: Tapped plug DIN 908

Type	G	ØD	ØD1	Ød	t	t1	x	a
UNF thread, low opening pressure								
RK 08 UNF RB 08 UNF	5/16-24 UNF-2B	(6.9)	4.7	4.7	10.5	8.5	2	8.5
RK 0 UNF RB 0 UNF	7/16-20 UNF-2B	(9.9)	5.5	5.5	12	10	2	9.5
RK 1 UNF RB 1 UNF	9/16-18 UNF-2B	(12.9)	8	8	17	14	3	13
RK 2 UNF RB 2 UNF	3/4-16 UNF-2B	(17.5)	10	10	19.5	17.5	2	14.5
RK 3 UNF RB 3 UNF	7/8-14 UNF-2B	(20.5)	12.5	12.5	24	21	3	18
RK 4 UN RB 4 UN	1 1/16-12 UN-2B	(24.9)	17	17	32.5	28.5	4	24

5**Installation, operation and maintenance information**

Observe the document B 5488 "General operating instructions for assembly, commissioning, and maintenance."

5.1 Intended use

This product is intended exclusively for hydraulic applications (fluid technology).

The user must observe the safety measures and warnings in this document.

Essential requirements for the product to function correctly and safely:

- ▶ All information in this documentation must be observed. This applies in particular to all safety measures and warnings.
- ▶ The product must only be assembled and put into operation by specialist personnel.
- ▶ The product must only be operated within the specified technical parameters described in detail in this document.
- ▶ All components must be suitable for the operating conditions when using an assembly.
- ▶ The operating instructions for the components, assemblies and the specific complete system must also always be observed.

If the product can no longer be operated safely:

1. Remove the product from operation and mark it accordingly.
 - ✓ It is then not permitted to continue using or operating the product.

5.2 Assembly information

The product must only be installed in the complete system with standard and compliant connection components (screw fittings, hoses, pipes, fixtures etc.).

The product must be shut down correctly prior to disassembly (in particular in combination with hydraulic accumulators).

**DANGER****Sudden movement of the hydraulic drives when disassembled incorrectly**

Risk of serious injury or death

- ▶ Depressurise the hydraulic system.
- ▶ Perform safety measures in preparation for maintenance.

5.2.1 Securing screw-in valves and fittings**NOTICE**

If stronger surges or vibrations are to be anticipated due to the mode of operation of the system in which the valves are used, as a precaution the valves and fittings must be protected against loosening when screwing into the bore holes provided using threadlocker (e.g. Loctite).

5.2.2 Creating the mounting hole

see Chapter 4, "Dimensions"

5.2.3 Assembly tool for type RK

(in-house production)

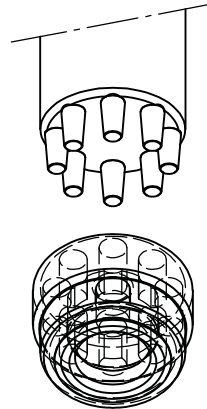
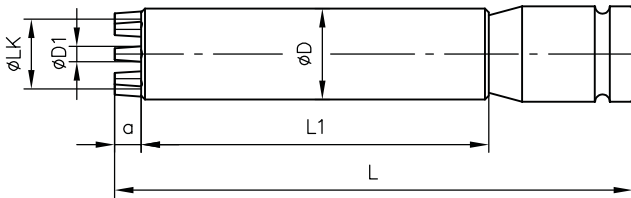

Type	$\varnothing D$	$\varnothing D1$	a	L	L1	$\varnothing LK$	Material no.
RK 08, RK 08 UNF	6.9	1.4	2	57	30	4.8	3200 3430-00
RK 08, RK 08 UNF	6.9	1.4	2	103	75	4.8	3200 3679-00
RK 0, RK 0 UNF RK 0-0.4	8.6	1.4	2	75.5	50.5	6.9	3200 2000-00
RK 1-.. RK 14-..	11.45	1.6	3	82	59	8.95	3200 2066-00
RK 1, RK 1 UNF RK 14	11.45	2	2.5	80.5	57.5	8.8	3200 2001-00
RK 1, RK 1 UNF RK 14	11.45	2	2.5	125.5	102.5	8.8	3200 2025-00
RK 2, RK 2 UNF RK 16	14.3	2.5	3	93	63	11	3200 2002-00
RK 2-.. RK 28-..	14.8	1.8	3	90	60	12.1	3200 2065-00
RK 3-.. RK 32-..	18.5	2.7	4	122	84	14.95	3200 2078-00
RK 3, RK 3 UNF RK 32	18.6	3	4	90	60	14.2	3200 2003-00
RK 4-.. RK 47-..	24	3.3	6	124	86	19	3200 2086-00
RK 4, RK 4 UN RK 47	24	4	7	137	92	18.5	3200 2004-00
RK 5 RK 5-..	30	4	8	136	90	23	3200 3658-00
RK 6-.. RK 62-..	38.6	5	10	138	100	30.5	3200 3607-00
RK 6	38.6	5	10	138	100	30	3200 3671-00
RK 7	44.5	6.5	13	157	103	35.5	3200 3678-00

NOTICE

The number of drilled holes in the check valve matches the number of pins on the tool.

5.3 Operating instructions

Observe product configuration and pressure/flow rate.

The statements and technical parameters in this document must be strictly observed.

The instructions for the complete technical system must also always be followed.

! NOTICE

- ▶ Read the documentation carefully before usage.
- ▶ The documentation must be accessible to the operating and maintenance staff at all times.
- ▶ Keep documentation up to date after every addition or update.

! CAUTION

Overloading components due to incorrect pressure settings.

Risk of minor injury. Parts may burst or fly off, and uncontrolled leakage of hydraulic fluid.

- Pay attention to the maximum operating pressure of the pump, valves and fittings.
- Always monitor the pressure gauge when setting and changing the pressure.

Purity and filtering of the hydraulic fluid

Fine contamination can significantly impair the function of the product. Contamination can cause irreparable damage.

Examples of fine contamination include:

- Swarf
- Rubber particles from hoses and seals
- Dirt due to assembly and maintenance
- Mechanical debris
- Chemical ageing of the hydraulic fluid

! NOTICE

New hydraulic fluid from the manufacturer may not have the required purity.

Damage to the product is possible.

- ▶ Filter new hydraulic fluid to a high quality when filling.
- ▶ Do not mix hydraulic fluids. Always use hydraulic fluid that is from the same manufacturer, of the same type, and with the same viscosity properties.

For smooth operation, pay attention to the cleanliness level of the hydraulic fluid (cleanliness level see Chapter 3, "Parameters").

Additionally applicable document: [D 5488/1](#) oil recommendations

5.4 Maintenance information

Check regularly (at least once a year) by visual inspection whether the hydraulic connections are damaged. If external leakages are found, shut down and repair the system.

Clean the surface of the device regularly (at least once a year) (dust deposits and dirt).