

THREE-PHASE MOTORS FOR EU MARKET

HIGH EFFICIENCY IE2 | 0.12 TO 0.55 KW
PREMIUM EFFICIENCY IE3 | 0.75 TO 200 KW

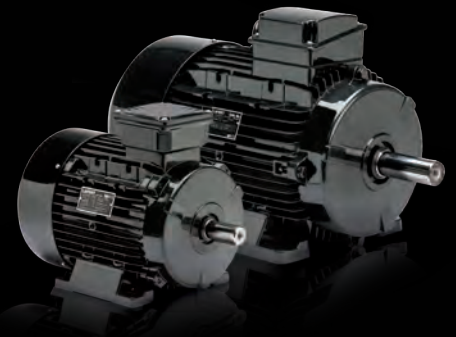
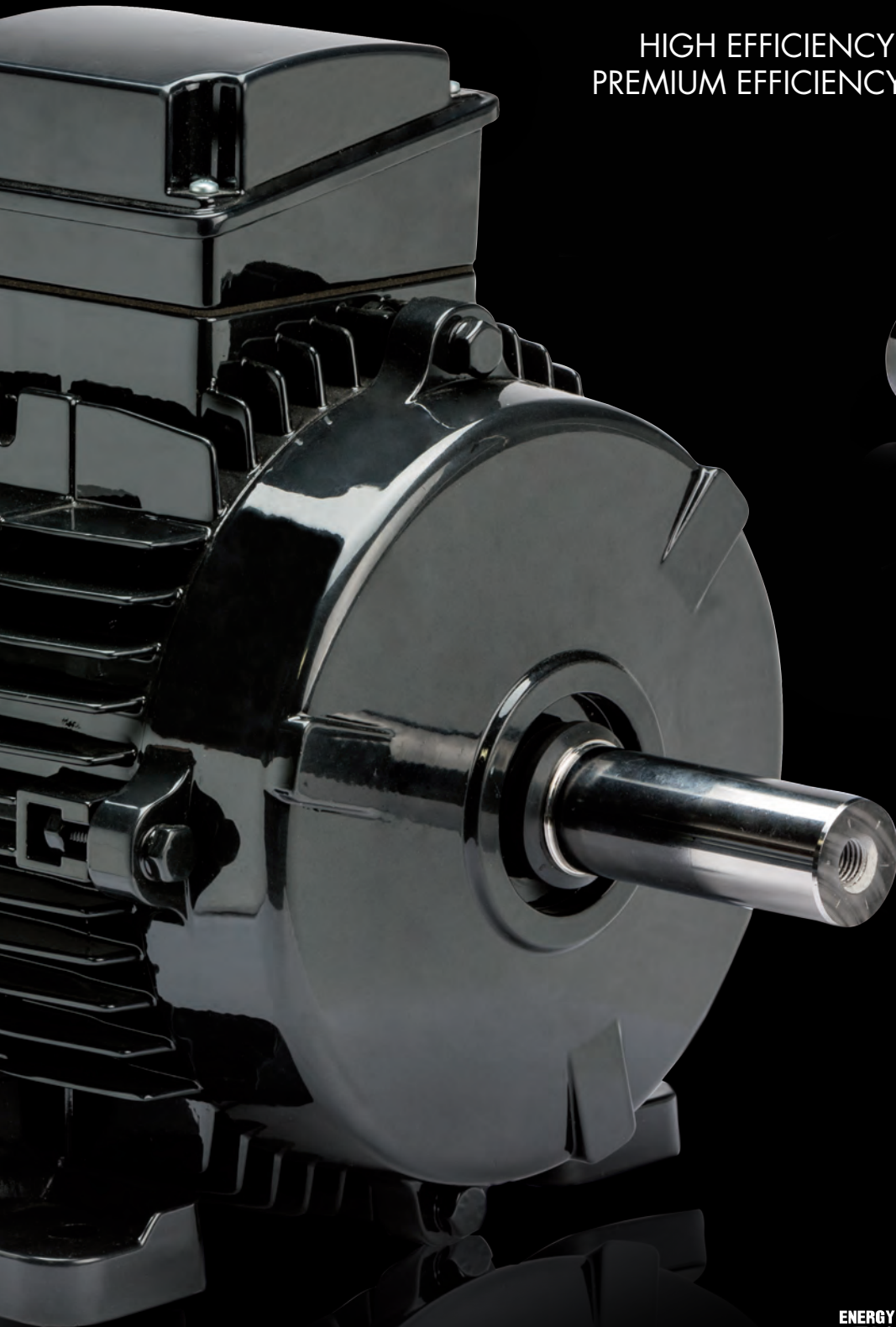

INTERNATIONAL EFFICIENCY LEVELS: IE CODES

The International Standard IEC 60034-30-1;2014 ensures a common base for electric motor designing and classification, as well as for national legislative activities, increasing the level of harmonization in **MEPS** (Minimum Energy Performance Standard) all over the world.

The IEC 60034-30-1 states the efficiency levels (IE codes) and requirements and provides test conditions and efficiency measurement methods specified in **IEC 60034-2-1;2014**. It doesn't state the minimum efficiency level (MEPS). This depends on any national legislative activities and government targets to save energy.



EUROPE: ECODESIGN REGULATION EU 2019/1781 AND AMENDMENT EU 2021/341

The Ecodesign Directive 2009/125/EC establishes, across the EU, a framework for setting eco-design requirements for energy-related products. It is a key instrument of EU policy for improving the energy efficiency and other aspects of the environmental performance of products placed on the market.

Requirements for the eco-design of electric motors and the use of variable speed drives were set out in Regulation (EC) 640/2009 on 22nd July 2009 then amended by Regulation (EU)

4/2014 on 6th January 2014. This regulation was superseded on 25th October 2019 by Regulation (EU) 2019/1781, which sets out new statutory requirements for motors and drives.

The Regulation EU 2019/1781 and Amendment EU 2021/341 specify efficiency requirements for single speed three-phase motors from 0.12 to 1000kW, 2, 4, 6 and 8 poles, 50 Hz, 60 Hz and 50/60 Hz, and introduce in all UE countries the following MEPS:

FIRST STEP: AS OF 1ST JULY 2021

IE2 level: 0.12 to 0.55 kW

IE3 level: 0.75 to 1.000 kW

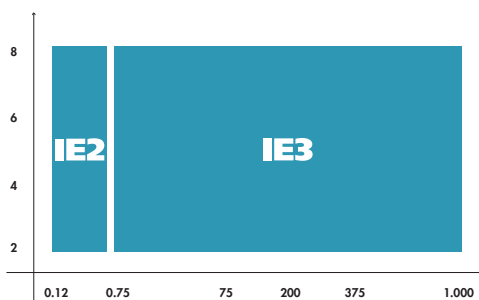

SECOND STEP: AS OF 1ST JULY 2023

IE2 level: 0.12 to 0.55 kW

IE2 level: 0.12 to 1.000 kW
(All Ex motors, Single-phase motors)

IE3 level: 0.75 to 1.000 kW

IE4 level: 75 to 200 kW

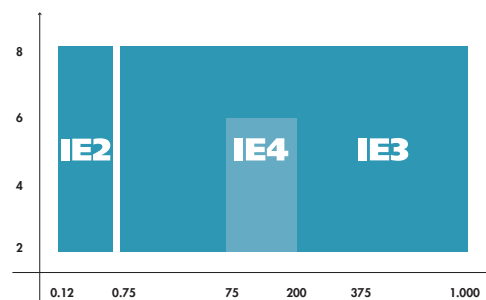

REGULATION SCOPE

- Three-phase single speed motors
- 0.12kW to 1000kW
- 2,4,6 and 8 poles
- 50 Hz, 60 Hz, 50/60 Hz
- Continuous duty operation (S1, S3>80%, S6>80%)
- Brake motors
- IC411 (TEFC) and IC418 (TEAO) design
- Ex motors (excluded Ex eb)

EXCLUSIONS

- Non continuous duty motors (duty<80%)
- IC410 (TENV) design
- Motors above +60°C and below -30°C

SPECIAL APPLICATIONS

The quality of Lafert motors is generated by the constant search for innovative solutions and from our natural propensity for customization and co-engineering. Lafert specializes in designing and manufacturing customized electric motors, created to meet the needs of each customer. **More than 90% of Lafert products are non-standard motors.**

Thanks to our strong approach to the market, experience in special applications and the wide range of solutions, we can offer an electric and mechanical design perfect for every application need. **The co-designing approach from our engineers** and the skillful expertise of our technical office to

adapt the motor to specific market segments allows us to offer an exceptionally high level of customization, efficiency and reliability.

To ensure the maximum performance of our motors **we produce every component internally.** This allows us to tailor every element of our proposals by developing infinite solutions for all applications.

From flange design to special windings, from the degree of protection to the fan cooling, we customize everything to create the perfect motor that maximizes the performance and energy savings of the final application.

TARGET APPLICATIONS

<p>WIND ENERGY</p> <p>MOTORS FOR YAW DRIVE & PITCH DRIVE, COOLING & VENTILATION, HYDRAULIC & POWER PACKS</p>	<p>MAIN FEATURES</p> <ul style="list-style-type: none"> • High reliability, low maintenance • High corrosion protection level (according to ISO 12944) • Special insulation system/voltage/frequency
<p>HVAC</p> <p>CENTRIFUGAL AND AXIAL FANS & PUMPS FOR INDUSTRIAL AND COMMERCIAL ENVIRONMENT</p>	<p>MAIN FEATURES</p> <ul style="list-style-type: none"> • Special shafts design • High corrosion protection level (according to ISO 12944) • Suitable for Variable Frequency Drive application • Pad mounting design
<p>COOLERS</p> <p>AIR COOLED RADIATORS FOR HEAVY INDUSTRIAL APPLICATIONS</p>	<p>MAIN FEATURES</p> <ul style="list-style-type: none"> • High corrosion protection level (according to ISO 12944) • Special insulation system/voltage/frequency • Wide ambient temperature range • Without ventilation (IC418 – TEAO design) • Pad mounting design
<p>AIR PROCESSING</p> <p>COMPRESSORS, VACUUM PUMPS, BLOWERS</p>	<p>MAIN FEATURES</p> <ul style="list-style-type: none"> • Special flanges and shafts • Dedicated electrical design to deliver required performances • High reliability



THREE-PHASE MOTOR RANGE FOR EU MARKET

HIGH EFFICIENCY IE2 – 0.12 TO 0.55 KW
 PREMIUM EFFICIENCY IE3 – 0.75 TO 200 KW

EFFICIENCY LEVEL ACCORDING TO IEC 60034-30-1;2014
 EFFICIENCY TESTING METHOD IEC 60034-2-1;2014

NOMINAL FULL LOAD EFFICIENCY ACCORDING TO IE3 CODE @ 400 V - 50 HZ

FOR MAINS VOLTAGE
 400 V - 50 HZ

IE2 IE3

TEMPERATURE RISE TO CLASS B

Type	kW	HP	min ⁻¹	M _N Nm	η			cos φ	I _N 400V	I _A /I _N	M _A /M _N	M _S /M _N	M _K /M _N	J 10 ⁻³ kgm ²	kg	
					50%	75%	100%									
56 TO 160: ALLUMINIUM DESIGN																
180 TO 315: CAST IRON DESIGN																
3000 min⁻¹ (2 poles)																
IE2	AMHE 56Z BA	2	0.12	0.16	2650	0.4	49.1	55.8	53.6	0.73	0.4	3.5	3.4	3.5	0.10	3.5
	AMHE 56Z CA	2	0.18	0.24	2660	0.6	55.0	59.8	60.4	0.64	0.7	3.9	3.8	3.9	0.09	3.4
	AMHE 63Z AA	2	0.18	0.25	2720	0.6	53.8	59.7	60.4	0.76	0.6	3.7	3.0	3.0	0.14	3.6
	AMHE 63Z BA	2	0.25	0.33	2790	0.9	60.8	67.2	64.8	0.68	0.8	4.5	3.2	3.2	0.17	4.1
	AMHE 63Z CA	2*	0.37	0.5	2750	1.3	59.1	66.2	69.5	0.69	1.1	4.6	3.4	3.3	0.20	4.4
	AMHE 71Z XA	2	0.37	0.5	2810	1.3	67.5	71.6	69.5	0.77	1.0	4.7	3.6	3.4	0.32	5.8
	AMHE 71Z YA	2	0.55	0.75	2780	1.9	72.9	76.7	74.1	0.80	1.3	4.8	3.2	3.1	0.37	6.2
	AMPE 71Z AA	2*	0.75	1	2880	2.5	76.5	80.8	80.7	0.70	1.9	5.5	3.1	3.0	0.69	8.2
	AMPE 80Z AA	2	0.75	1	2910	2.5	77.8	81.2	82.0	0.78	1.7	8.9	4.7	4.5	0.7	9.5
	AMPE 80Z BA	2	1.1	1.5	2870	3.7	78.7	81.7	82.7	0.76	2.4	9.3	5.0	4.9	0.9	11.1
AMPE 80Z CA	2*	1.5	2	2810	5.1	78.8	82.2	84.2	0.76	3.6	7.8	4.9	3.7	1.1	13.5	
AMPE 90S AA	2	1.5	2	2875	5.0	83.2	84.8	84.2	0.85	3.0	8.4	3.6	3.2	3.8	1.56	14.0
AMPE 90L BA	2	2.2	3	2880	7.3	85.0	86.2	86.5	0.82	4.6	9.2	4.0	3.8	4.2	1.8	16.0
AMPE 90L DA	2*	3	4	2865	10.0	85.2	86.3	87.1	0.80	6.3	8.7	4.5	4.0	4.6	2.0	18.0
AMPE 100L AA	2	3	4	2900	9.9	82.3	85.8	87.1	0.89	5.6	8.8	5.5	3.5	4.5	4.05	22.8
AMPE 100L BA	2*	4	5.5	2920	13.1	85.4	87.2	88.1	0.81	8.2	10.9	6.1	5.2	5.7	7.3	26.5
AMPE 112M AA	2	4	5.5	2910	13.1	86.8	87.8	88.1	0.93	7.0	9.6	3.6	3.0	4.0	6.48	27.4
AMPE 112M BA	2*	5.5	7.5	2935	17.9	85.6	88.3	89.2	0.87	10.2	11.2	4.2	3.5	4.3	8.6	33.6
AMPE 112M CA	2*	7.5	10	2930	24.5	88.0	89.7	90.1	0.84	14.4	10.4	4.5	3.5	4.6	10.5	36.0
AMPE 132S ZA	2	5.5	7.5	2920	18.0	88.0	88.5	89.2	0.90	10.0	8.9	3.0	2.5	3.6	14.0	46.0
AMPE 132S TA	2	7.5	10	2910	24.6	88.6	89.2	90.1	0.92	13.1	8.9	3.0	2.6	3.6	16.0	53.0
AMPE 132M ZA	2	9.2	12.4	2930	30.0	88.6	89.8	90.7	0.89	16.5	10.1	3.7	3.3	4.0	17.5	58.0
AMPE 132M RA	2*	11	15	2935	35.8	90.0	90.8	91.2	0.89	19.9	9.7	4.4	3.5	4.6	25.0	59.0
AMPE 132M TA	2*	15	20	2915	49.2	91.0	92.2	91.9	0.88	26.8	9.6	3.7	2.6	3.8	28.0	68.0
AMPE 160M YA	2	11	15	2950	35.6	87.4	89.8	91.2	0.89	19.7	9.1	4.0	3.0	4.2	51.7	87.8
AMPE 160M ZA	2	15	20	2940	48.7	91.0	91.3	91.9	0.89	26.7	9.7	4.7	3.5	4.8	53.4	88.9
AMPE 160L ZA	2	18.5	25	2950	59.9	91.6	92.8	92.4	0.88	33.0	10.7	4.6	3.1	4.7	64.0	104.0
AMPE 160L TA	2*	22	30	2950	71.3	92.2	93.7	92.7	0.87	39.4	10.4	4.5	3.0	4.6	64.0	104.0
AMPE 180M ZG	2	22	30	2945	71.7	93.6	94.1	92.7	0.89	38.5	7.5	2.3	2.0	2.8	97	210
AMPE 200L PG	2	30	40	2945	97.9	93.2	93.8	93.3	0.88	52.7	6.7	2.4	2.0	2.7	173	234
AMPE 200L RG	2	37	50	2945	120.6	94.2	94.4	93.7	0.90	64.0	6.3	2.3	2.0	2.7	200	250
AMPE 225M PG	2	45	60	2950	146.7	94.1	94.6	94.0	0.88	75.9	6.9	2.3	2.0	2.8	344	322
AMPE 250M PG	2	55	75	2960	178.6	93.1	94.5	94.3	0.88	93.5	8.0	2.3	1.9	2.7	444	420
AMPE 280S G	2	75	100	2960	243.6	93.7	94.9	94.7	0.92	125.6	8.0	2.2	1.9	2.7	829	630
AMPE 280M G	2	90	125	2960	292.3	94.3	95.2	95.0	0.92	150.3	7.7	2.2	1.9	2.6	982	650
AMPE 315S G	2	110	150	2960	357.3	94.6	95.5	95.2	0.90	185.3	7.7	2.0	1.8	2.3	1509	930
AMPE 315M G	2	132	180	2960	428.7	94.7	95.5	95.4	0.91	221.9	7.6	2.0	1.8	2.3	1938	1030
AMPE 315L RG	2	160	200	2960	518.8	94.5	95.8	95.6	0.90	268.4	7.8	2.0	1.8	2.3	2197	1070
AMPE 315L G	2	200	270	2960	648.5	94.7	96.0	95.8	0.89	334.8	7.9	2.0	1.8	2.3	2554	1140

* Higher output (progressive motor)

THREE-PHASE MOTOR RANGE FOR EU MARKET

HIGH EFFICIENCY IE2 – 0.12 TO 0.55 KW
 PREMIUM EFFICIENCY IE3 – 0.75 TO 200 KW

EFFICIENCY LEVEL ACCORDING TO IEC 60034-30-1;2014
 EFFICIENCY TESTING METHOD IEC 60034-2-1;2014

NOMINAL FULL LOAD EFFICIENCY ACCORDING TO IE3 CODE @ 400 V - 50 HZ

FOR MAINS VOLTAGE
 400 V - 50 HZ

IE2 IE3

TEMPERATURE RISE TO CLASS B

Type	kW	HP	min ⁻¹	M _N Nm	η			cos φ	I _N 400V	I _A /I _N	M _A /M _N	M _S /M _N	M _K /M _N	J 10 ⁻³ kgm ²	kg		
					50%	75%	100%										
56 TO 160: ALLUMINIUM DESIGN 180 TO 315: CAST IRON DESIGN																	
1500 min ⁻¹ (4 poles)																	
IE2	AMHE 63Z AA	4	0.12	0.16	1330	0.8	61.3	62.6	59.1	0.67	0.4	2.4	2.0	1.9	2.0	0.25	3.3
	AMHE 63Z BA	4	0.18	0.25	1345	1.3	61.9	66.7	64.7	0.66	0.6	2.3	1.9	1.8	1.9	0.27	4.1
	AMHE 63Z CA	4*	0.25	0.33	1356	1.8	67.3	71.3	68.5	0.65	0.9	2.7	2.2	2.0	2.1	0.30	4.2
	AMHE 71Z AA	4	0.25	0.33	1390	1.8	67.0	71.2	68.5	0.77	0.7	3.2	1.9	1.8	2.0	0.65	5.7
	AMHE 71Z BA	4	0.37	0.50	1410	2.6	68.4	73.3	72.7	0.70	1.0	3.3	2.2	2.1	2.2	0.76	6.0
	AMHE 71Z CA	4*	0.55	0.75	1410	3.8	71.5	75.5	77.1	0.71	1.5	3.6	2.4	2.3	2.4	1.00	7.3
	AMHE 80Z XA	4	0.55	0.75	1422	3.8	75.1	77.8	77.1	0.72	1.5	3.6	2.6	2.5	2.6	1.38	8.2
	AMPE 80Z AA	4	0.75	1	1435	5.0	80.7	81.5	82.5	0.74	1.8	5.5	2.7	2.6	2.8	2.5	11.0
	AMPE 90S AA	4	1.1	1.5	1440	7.3	83.3	84.3	84.1	0.75	2.5	7.1	4.3	3.4	4.4	3.6	15.8
	AMPE 90L BA	4	1.5	2	1430	10.0	84.1	85.2	85.3	0.72	3.6	6.6	4.3	3.8	4.4	3.7	16.4
AMPE 90L CA4	4	1.8	2.4	1430	12.0	83.5	86.1	86.0	0.69	4.5	8.5	4.3	3.7	4.4	3.9	20.0	
AMPE 100L AA	4	2.2	3	1455	14.4	83.2	86.2	86.7	0.63	5.9	7.2	3.7	3.0	3.9	5.9	22.8	
AMPE 100L BA	4	3	4	1440	19.9	85.1	87.1	87.7	0.73	6.8	8.1	4.1	3.8	4.1	7.3	26.5	
AMPE 112M BA	4	4	5.5	1450	26.4	87.2	88.3	88.6	0.80	8.2	8.5	2.7	2.4	3.5	16.4	36.0	
AMPE 132S AA	4	5.5	7.5	1460	35.9	90.6	91.3	89.6	0.84	10.6	8.6	2.5	2.1	3.5	33.0	60.0	
AMPE 132M BA	4	7.5	10	1465	48.9	90.8	91.5	90.4	0.84	14.2	8.6	2.5	2.1	3.5	36.0	65.0	
AMPE 132M CA	4	9.2	12.4	1460	60.1	91.0	91.6	91.0	0.84	17.3	8.7	2.4	2.0	3.6	45.0	63.0	
AMPE 132M DA	4	11	15	1470	71.1	90.6	91.5	91.4	0.80	21.8	8.7	2.4	2.0	3.6	57.0	77.0	
AMPE 160M AA	4	11	15	1475	71.3	91.6	92.4	91.4	0.83	21.0	8.2	2.1	1.7	2.8	89.0	100.0	
AMPE 160L BA	4	15	20	1465	97.8	92.2	92.7	92.1	0.83	28.5	7.8	2.3	2.0	3.1	105.0	105.0	
AMPE 160L CA	4*	18.5	25	1470	122	92.0	92.8	92.6	0.78	37.0	7.1	2.1	1.9	2.6	120.7	110.0	
AMPE 160L DA	4*	22	30	1470	143.9	92.4	93.1	93.0	0.76	45.0	8.0	2.2	1.9	3.0	128.1	115.0	
AMPE 180M ZG	4	18.5	25	1460	122.3	92.3	92.6	92.6	0.86	33.5	7.8	2.4	2.1	3.0	155	160	
AMPE 180L ZG	4	22	30	1460	143.9	92.8	93.0	93.0	0.87	39.2	7.5	2.3	2.0	3.0	194	186	
AMPE 200L RG	4	30	40	1470	196.2	92.5	93.6	93.6	0.81	57.1	7.9	2.4	2.0	2.7	287	245	
AMPE 225S PG	4	37	50	1470	240.4	93.5	93.9	93.9	0.87	65.4	6.7	2.4	2.0	2.7	578	320	
AMPE 225M PG	4	45	60	1470	290.3	93.7	94.2	94.2	0.87	79.2	7.0	2.3	2.0	2.8	653	350	
AMPE 250M PG	4	55	75	1470	354.9	94.0	94.6	94.6	0.88	95.4	7.4	2.4	1.9	2.7	765	460	
AMPE 280S G	4	75	100	1480	483.9	94.8	95.0	95.0	0.87	131.0	7.5	2.2	1.9	2.6	1887	620	
AMPE 280M G	4	90	125	1480	580.7	94.3	95.2	95.2	0.85	160.5	7.7	2.2	1.9	2.6	2183	673	
AMPE 315S G	4	110	150	1480	109.7	94.6	95.4	95.4	0.88	189.1	7.8	2.0	1.8	2.3	3718	1027	
AMPE 315M G	4	132	180	1480	851.7	95.0	95.6	95.6	0.88	226.5	7.8	2.0	1.8	2.3	4297	1070	
AMPE 315L RG	4	160	200	1480	1032.4	95.1	95.8	95.8	0.88	273.9	7.9	2.0	1.8	2.3	5120	1150	
AMPE 315L G	4	200	270	1480	1290.4	95.3	96.0	96.0	0.89	337.9	7.7	2.0	1.8	2.3	6173	1230	

* Higher output (Progressive motor)

THREE-PHASE MOTOR RANGE FOR EU MARKET

HIGH EFFICIENCY IE2 – 0.12 TO 0.55 KW

PREMIUM EFFICIENCY IE3 – 0.75 TO 200 KW

EFFICIENCY LEVEL ACCORDING TO IEC 60034-30-1;2014

EFFICIENCY TESTING METHOD IEC 60034-2-1;2014

NOMINAL FULL LOAD EFFICIENCY ACCORDING TO IE3 CODE @ 400 V - 50 HZ

FOR MAINS VOLTAGE
400 V - 50 HZ

IE2 IE3

TEMPERATURE RISE TO CLASS B

Type	kW	HP	min ⁻¹	M _N Nm	η			cos φ	I _N 400V	I _A /I _N	M _A /M _N	M _S /M _N	M _K /M _N	J 10 ⁻³ kgm ²	kg		
					50%	75%	100%										
56 TO 160: ALLUMINIUM DESIGN																	
180 TO 315: CAST IRON DESIGN																	
1000 min ⁻¹ (6 poles)																	
IE2	AMEE 71Z AA	6	0.18	0.25	886	2.0	58.7	60.4	56.6	0.61	0.7	2.2	1.6	1.5	1.6	1.00	6.1
	AMEE 71Z BA	6	0.25	0.33	860	2.7	62.0	62.7	61.6	0.65	0.9	2.5	1.7	1.6	1.7	1.19	6.6
	AMEE 80Z AA	6	0.37	0.5	937	3.8	70.2	71.8	67.6	0.75	1.0	2.7	1.6	1.6	2.1	1.83	8.0
	AMEE 80Z BA	6	0.55	0.75	922	5.7	66.9	71.2	73.1	0.74	1.5	2.9	2.2	2.1	2.1	2.36	9.4
	AMPE 90S AA	6	0.75	1	940	7.6	78.1	79.2	78.9	0.62	2.2	4.6	1.7	1.6	1.8	6.0	18.1
	AMPE 90L BA	6	1.1	1.5	935	11.2	79.1	81.2	81.0	0.64	3.1	4.2	1.8	1.7	2.3	6.5	19.0
IE3	AMPE 100L AA	6	1.1	1.5	960	10.9	78.9	81.3	81.0	0.65	3.0	6.2	2.2	1.8	2.8	11.6	25.0
	AMPE 100L BA	6	1.5	2	920	15.6	81.1	82.7	82.5	0.68	3.8	5.7	1.7	1.3	2.3	14.2	26.0
	AMPE 112M BA	6	2.2	3	920	22.8	83.3	85.1	84.3	0.68	5.4	5.3	2.0	1.8	2.4	20.1	34.2
	AMPE 132S YA	6	3	4	975	29.4	84.1	85.8	85.6	0.65	8.0	5.5	2.1	1.9	3.1	37.7	42.0
	AMPE 132M YA	6	4	5.5	975	39.2	85.2	87.1	86.8	0.66	10.3	5.4	2.2	1.7	3.2	44.4	46.0
	AMPE 132M TA	6*	5.5	7.5	975	53.9	87.1	88.1	88.0	0.64	14.2	5.4	2.1	1.8	2.9	54.1	48.0
	AMPE 160M YA	6	5.5	7.5	975	53.9	87.5	88.5	88.0	0.77	11.8	8.6	2.2	1.8	2.8	103.0	84.0
	AMPE 160LM ZA	6	7.5	10	980	73.1	88.3	89.3	89.1	0.78	15.7	8.7	2.4	1.9	3.1	132.0	97.0
	AMPE 160L ZA	6	9.2	12.4	970	87.6	88.9	90.1	89.8	0.74	19.9	8.3	3.1	2.2	3.5	136.0	105.0
	AMPE 160L TA	6	11	15	970	108.3	89.1	90.4	90.3	0.78	22.9	8.0	2.7	2.4	3.2	136.0	105.0
	AMPE 180L ZG	6	15	20	960	149.2	90.3	92.0	91.2	0.83	28.6	7.8	2.3	2.1	2.9	257	152
	AMPE 200L PG	6	18.5	25	970	183.1	91.2	92.0	91.7	0.85	34.3	7.8	2.4	2.1	3.2	383	188
	AMPE 200L RG	6	22	30	970	217.7	91.5	92.4	92.2	0.86	40.0	7.9	2.3	1.9	3.1	449	250
	AMPE 225M PG	6	30	40	975	293.8	93.5	93.6	92.9	0.85	54.8	7.9	2.2	1.9	2.7	670	252
	AMPE 250M PG	6	37	50	975	362.4	91.8	94.0	93.3	0.83	69.0	7.5	2.3	2.1	2.7	992	345
	AMPE 280S G	6	45	60	980	438.5	92.2	93.5	93.7	0.86	80.6	7.2	2.3	2.0	2.8	2046	410
	AMPE 280M G	6	55	75	980	535.9	92.8	93.9	94.1	0.86	98.1	7.7	2.2	1.9	2.7	2573	520
	AMPE 315S G	6	75	100	980	730.8	93.2	94.8	94.6	0.89	128.6	7.9	2.1	1.9	2.5	4157	530
	AMPE 315M G	6	90	125	980	877.0	93.4	95.0	94.9	0.90	152.1	8.0	2.0	1.8	2.3	3530	860
	AMPE 315L RG	6	110	150	980	1071.9	94.0	95.4	95.1	0.90	185.5	7.7	2.0	1.8	2.3	4173	970
AMPE 315L G	6	132	180	980	1286.2	94.2	95.7	95.4	0.89	224.4	8.0	2.0	1.8	2.3	5167	1010	

* Higher output (Progressive motor)

THREE-PHASE MOTORS | FRAME SIZE 56 – 315 IM B3

56 TO 160 ALUMINIUM DESIGN | 180 TO 315 CAST IRON DESIGN

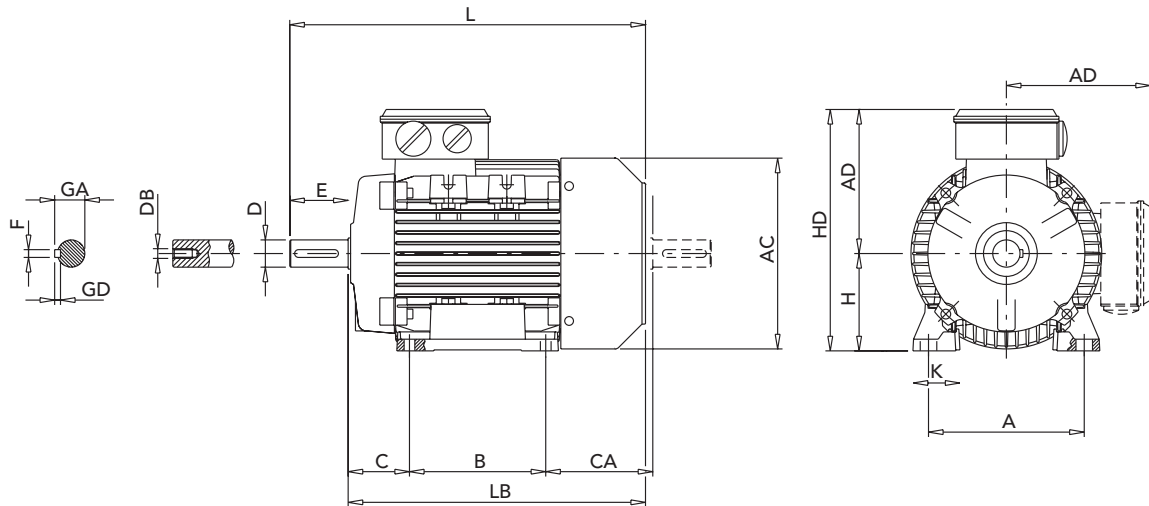

IEC	Poles	kW	H	A	B	C	CA	AD ¹⁾	HD ¹⁾	AC	HC	L	LB	D	E	F	GD	GA	DB ²⁾
56	2	all	56	90	71	36	6	64	92	148	110	188	168	9	20	3	3	10.2	M3
63	2 - 4	all	63	100	80	40	7	72	96	159	124	211	188	11	23	4	4	12.5	M4
71	2 - 4 - 6	all	71	112	90	45	8	83	110	181	139	246	216	14	30	5	5	16	M5
80	2 - 4 - 6	all	80	125	100	50	10	89	129	209	160	272	232	19	40	6	6	21.5	M6
90S	2 - 4 - 6	all	90	140	100	56	10	116	138	228	180	317	267	24	50	8	7	27	M8
90L	2	2.2	90	140	125	56	10	91	138	228	180	317	267	24	50	8	7	27	M8
	2	3	90	140	125	56	10	114	138	228	180	340	290	24	50	8	7	27	M8
	4	1.8	90	140	125	56	10	114	138	228	180	340	290	24	50	8	7	27	M8
	4 - 6	all	90	140	125	56	20	91	138	228	180	317	267	24	50	8	7	27	M8
100	2 - 4 - 6	all	100	160	140	63	11	110	145	245	196	366	306	28	60	8	7	31	M10
112	2 - 4 - 6	all	112	190	140	70	12.5	126	160	272	225	388	328	28	60	8	7	31	M10
	2	7.5	112	190	140	70	12.5	148	160	272	222	410	350	28	60	8	7	31	M10
132S	2 - 4 - 6	all	132	216	140	89	12	134	194	326	248	445	365	38	80	10	8	41	M12
	2	7.5	132	216	140	89	12	154	194	326	248	465	385	38	80	10	8	41	M12
132M	2	9.2 - 11	132	216	178	89	12	156	194	326	248	505	425	38	80	10	8	41	M12
	2	15	132	216	178	89	12	156	194	326	248	556	476	38	80	10	8	41	M12
	4	7.5	132	216	178	89	12	136	194	326	248	485	405	38	80	10	8	41	M12
	4	9.2	132	216	178	89	12	207	194	326	248	505	425	38	80	10	8	41	M12
	4	11	132	216	178	89	12	156	194	326	248	505	425	38	80	10	8	41	M12
	6	4	132	216	178	89	12	136	194	326	248	485	405	38	80	10	8	41	M12
160M	2 - 4 - 6	all	160	254	210	108	14	180	238	398	317	608	498	42/28	110/60	12/8	8/7	45/31	M16/M10
	2 - 4 - 6	all	160	254	254	108	14	180	238	398	317	652	542	42/28	110/60	12/8	8/7	45/31	M16/M10
180M	2 - 4 - 6	all	180	279	241	121	15	na	259	439	360	687	797	48	110	14	9	51.5	M16
180L	2 - 4 - 6	all	180	279	279	121	15	na	259	439	360	725	835	48	110	14	9	51.5	M16
200	2 - 4 - 6	all	200	318	305	133	19	na	297	497	399	768	878	55	110	16	10	59	M20
225S	4 - 6	all	225	356	286	149	19	na	328	553	465	814	954	60	140	18	11	64	M20
225M	2	all	225	356	311	149	19	na	358	553	465	809	919	55	110	16	10	59	M20
	4 - 6	all	225	356	311	149	19	na	328	553	465	839	979	60	140	18	11	64	M20
250	2	all	250	406	349	168	24	na	366	616	506	918	1058	60	140	18	11	64	M20
	4 - 6	all	250	406	349	168	24	na	366	616	506	918	1058	65	140	18	11	69	M20
280S	2	all	280	457	368	190	24	na	388	668	559	984	1124	65	140	18	11	69	M20
	4 - 6	all	280	457	368	190	24	na	388	668	559	984	1124	75	140	20	12	79.5	M20
280M	2	all	280	457	419	190	24	na	388	668	559	1035	1175	65	140	18	11	69	M20
	4 - 6	all	280	457	419	190	24	na	388	668	559	1035	1175	75	140	20	12	79.5	M20
315S	2	all	315	508	406	216	28	na	530	845	680	1205	1495	65	140	18	11	69	M20
	4 - 6	all	315	508	406	216	28	na	530	845	680	1235	1555	80	170	22	14	85	M20
315M	2	all	315	508	457	216	28	na	530	845	680	1355	1495	65	140	18	11	69	M20
	4 - 6	all	315	508	457	216	28	na	530	845	680	1385	1555	80	170	22	14	85	M20
315L	2	all	315	508	508	216	28	na	530	845	680	1355	1495	65	140	18	11	69	M20
	4 - 6	all	315	508	508	216	28	na	530	845	680	1385	1555	80	170	22	14	85	M20

1) Maximum distance

2) Centering holes in shaft extensions to DIN 332 part 2

