

## T 8384-3 EN

### Type 3730-3 Electropneumatic Positioner with HART® communication · Series 3730



#### Anwendung

Single-acting or double-acting positioner for attachment to pneumatic control valves. Self-calibrating, automatic adaptation to valve and actuator.

<b>Set point</b>	<b>4 to 20 mA</b>
<b>Valve travel</b>	<b>3.6 to 300 mm</b>
<b>Opening angle</b>	<b>24 to 100°</b>

The positioner ensures a predetermined assignment of the valve position (controlled variable  $x$ ) to the input signal (set point  $w$ ). It compares the input signal received from a control system to the travel or rotational angle of the control valve and issues a corresponding output signal pressure (output variable  $y$ ).

#### Special features

- Simple attachment to all common linear and rotary actuators
  - SAMSON direct attachment (Fig. 1)
  - NAMUR rib (Fig. 2)
  - Attachment to rod-type yokes acc. to IEC 60534-6-1
  - Attachment according to VDI/VDE 3847
  - Rotary actuator attachment according to VDI/VDE 3845 (Fig. 3)
- Any desired mounting position of the positioner (but not suspended)
- Simple single-knob, menu-driven operation
- LCD easy to read in any mounted position due to selectable reading direction
- Configurable with a PC over the SSP interface using the TROVIS-VIEW software
- Variable, automatic start-up with four different initialization modes
- Preset parameters - only values deviating from the standard need to be adjusted
- Calibrated travel sensor without gears susceptible to wear
- Sub initialization mode (substitution) allows the positioner to be started up in case of emergency whilst the plant is running without the valve moving through the whole travel range.
- Permanent storage of all parameters in EEPROM (protected against power failure)
- Two-wire system with a small electrical load of 410  $\Omega$
- Adjustable output pressure limitation

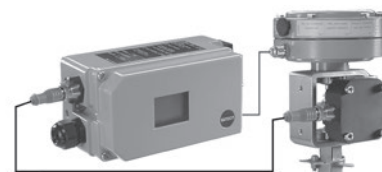

**Fig. 1:** Type 3730, direct attachment to Type 3277 Pneumatic Actuator (new design)

**Fig. 2:** Type 3730, attachment to NAMUR rib



**Fig. 3:** Type 3730, attachment according to VDI/VDE 3845



**Fig. 4:** Type 3730 · External position sensor with Type 3510 Micro-flow Valve

- Activatable tight-closing function
- Continuous monitoring of zero point
- Integrated temperature sensor and operating hours counter
- Two standard programmable position alarms
- Self-diagnostics; alarms as condensed state conforming to NAMUR Recommendation NE 107, issued over a fault alarm contact or optional analog position transmitter
- Integrated EXPERTplus diagnostics for control valves (▶ T 8389)

#### Versions

- **Type 3730-3** · Electropneumatic positioner for control valves, on-site operation, local communication with SSP interface, EXPERTplus diagnostics, HART® communication
- **Type 3730-6** · Electropneumatic positioner for control valves, HART® communication, on-site operation, local communication with SSP interface, EXPERTplus diagnostics, pressure sensors to monitor the supply air and signal pressure ▶ T 8384-6

#### Additional options

- Inductive limit contact with proximity switches
- Analog position transmitter with two-wire transmitter
- Forced venting function with solenoid valve
- Binary input
- External position sensor (Fig. 4)
- Analog input x
- Stainless steel housing
- Leakage sensor to monitor the seat leakage

#### Principle of operation

The positioner is mounted on pneumatic control valves and is used to assign the valve position (controlled variable x) to the control signal (set point w). The positioner compares the electric control signal of a control system to the travel or rotational

angle of the control valve and issues a signal pressure (output variable y) for the pneumatic actuator.

The positioner mainly consists of an electric travel sensor system (2), an analog i/p module with a downstream air capacity booster and the electronics with the microcontroller (5).

When a set point deviation occurs, the actuator is either vented or filled with air. If necessary, the signal pressure change can be slowed down with a volume restriction that can be connected as necessary. The signal pressure to the actuator can be limited by software to 1.4, 2.4 or 3.7 bar.

A constant air stream with a fixed set point to the atmosphere is created by flow regulator (9) with a fixed set point. The i/p module (6) is supplied with a constant upstream pressure by the pressure regulator (8) to compensate for any fluctuations in the supply pressure.

#### Operation

The positioner is operated with a user-friendly rotary pushbutton. The parameters are selected by turning the knob, pushing it activates the required setting. In the menu, all parameters are listed in one level, eliminating the need to search in sub-menus. All parameters can be checked and changed on site. All values are displayed on the LCD. The reading direction of the LCD can be rotated by 180°.

The closing direction of the control valve is indicated to the positioner by setting the slide switch "Air to open/Air to close". It assigns the CLOSED position of the control valve to the 0 % reading.

The INIT key activates initialization which is started according to the ready adjusted parameters (autotune). After initialization is completed, the positioner immediately starts closed-loop operation.

To configure the positioner with SAMSON's TROVIS-VIEW software, the positioner is equipped with an additional digital interface to be connected to the RS-232 or USB interface of a PC.

All parameters can be accessed using HART® communication.

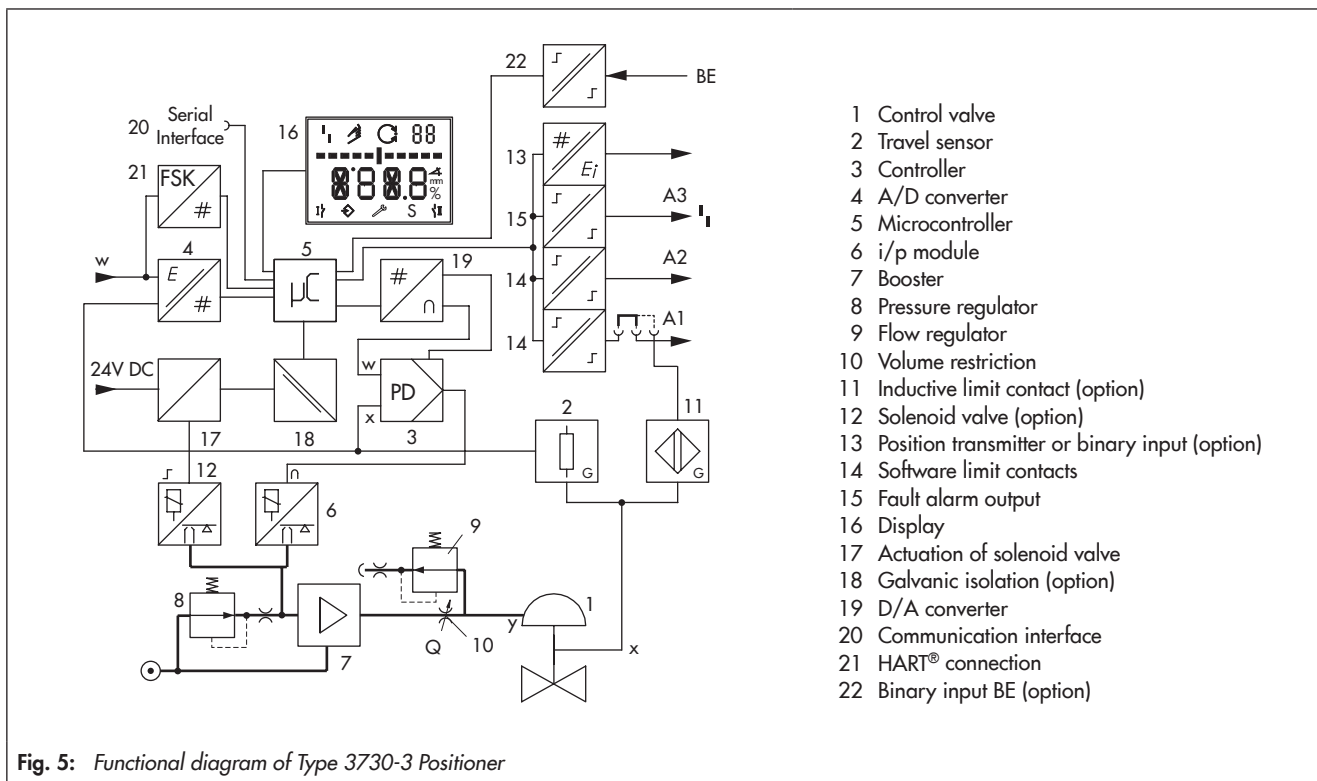



Fig. 5: Functional diagram of Type 3730-3 Positioner

**Table 1: Technical data for Type 3730-3 Positioner**

Type 3730-3 Positioner		The technical data for the explosion-protected devices may be restricted by the limits specified in the test certificates.	
Valve travel	Adjustable	Direct attachment to Type 3277 Actuator	3.6 to 30 mm
		Attachment according to IEC 60534-6 (NAMUR)	3.6 to 300 mm
		Attachment according to VDI/VDE 3847	3.6 to 300 mm
		Attachment to rotary actuators (VDI/VDE 3845)	24 to 100° opening angle
Travel range	Adjustable	Adjustable within the initialized travel/angle of rotation of the valve; travel can be restricted to 1/5 at the maximum.	
Set point w	Signal range	4 to 20 mA · Two-wire device, reverse polarity protection Minimum span 4 mA	
	Static destruction limit	100 mA	
Minimum current		3.6 mA for display · 3.8 mA for operation	
Load impedance		≤ 8.2 V (corresponds to 410 Ω at 20 mA)	
Supply air	Supply pressure	1.4 to 7 bar (20 to 105 psi)	
	Air quality acc. to ISO 8573-1	Max. particle size and density: Class 4 · Oil content: Class 3 · Pressure dew point: Class 3 or at least 10 K below the lowest ambient temperature to be expected	
Signal pressure (output)		0 bar up to the capacity of the supply pressure · Can be limited to 1.4 bar/2.4 bar/3.7 bar ± 0.2 bar by software	
Characteristic	Adjustable	Linear/equal percentage/reverse equal percentage User-defined (over operating software and communication) Butterfly valve, rotary plug valve and segmented ball valve: linear/equal percentage	
	Deviation	≤ 1 %	
Hysteresis		≤ 0.3 %	
Sensitivity		≤ 0.1 %	
Transit time		Venting or filling with air adjustable separately up to 240 s by software	
Direction of action		Reversible	
Air consumption, steady state		Independent of supply air approx. 110 l <sub>n</sub> /h	
Air output ca- capacity	to fill actuator with air	At Δp = 6 bar: 8.5 m <sub>n</sub> <sup>3</sup> /h · At Δp = 1.4 bar: 3.0 m <sub>n</sub> <sup>3</sup> /h · K <sub>Vmax(20 °C)</sub> = 0.09	
	to vent actuator	At Δp = 6 bar: 14.0 m <sub>n</sub> <sup>3</sup> /h · At Δp = 1.4 bar: 4.5 m <sub>n</sub> <sup>3</sup> /h · K <sub>Vmax(20 °C)</sub> = 0.15	
Permissible ambient temperature		-20 to +80 °C (all versions) -45 to +80 °C with metal cable gland -55 to +80 °C Special version for low temperatures with metal cable gland (on request) <b>The temperature limits for the explosion-protected devices may be further restricted by the limits specified in the test certificates.</b>	
Influences	Temperature	≤ 0.15 %/10 K	
	Supply air	None	
	Effect of vibration	≤ 0.25 % up to 2000 Hz and 4 g according to IEC 770	
Electromagnetic compatibility		Complying with EN 61000-6-2, EN 61000-6-3, EN 61326-1 and NAMUR Recommendation NE 21	
Electrical connections		One M20x1.5 cable gland for 6 to 12 mm clamping range Second M20x1.5 threaded connection additionally available Screw terminals for 0.2 to 2.5 mm <sup>2</sup> wire cross-section	
Degree of protection		IP 66/NEMA 4X	
Use in safety-instrumented systems (SIL)		Observing the requirements of IEC 61508, the systematic capability of the pilot valve for emergency venting as a component in safety-instrumented systems is given.	
Emergency venting at 0 mA set point and using optional solenoid valve		Use is possible on observing the requirements of IEC 61511 and the required hardware fault tolerance in safety-instrumented systems up to SIL 2 (single device/HFT = 0) and SIL 3 (redundant configuration/HFT = 1).	
<b>Explosion protection</b>		See Table 3	
Communication (local)		SAMSON SSP interface and serial interface adapter	
Software requirements (SSP)		TROVIS-VIEW with database module 3730-3	
Communication (HART®)		HART® field communication protocol Impedance in HART® frequency range: Receiving 350 to 450 Ω · Sending approx. 115 Ω	
Software requirements (HART®)	For handheld communicator	Device description for Type 3730-3	
	For PC	DTM file according to specification 1.2, suitable for integrating the device into frame applications that support the use of FDT/DTM (e.g. PACTware); other integrations (e.g. AMS, PDM) available	
Compliance			



Binary contacts		
For connection to	Binary input of a PLC acc. to IEC 61131-2 $P_{max} = 400 \text{ mW}$ or for connection to NAMUR switching amplifier acc. to EN 60947-5-6	NAMUR switching amplifier acc. to EN 60947-5-6
Two software limit contacts, reverse polarity protection, floating, configurable switching characteristics (default settings in table below)		
Signal state	<b>Version</b>	<b>No explosion protection</b>
	No response	Effectively non-conducting
	Response	Conductive ( $R = 348 \Omega$ )
		<b>Ex</b>
		$\leq 1.0 \text{ mA}$
		$\geq 2.2 \text{ mA}$
One fault alarm contact		
Signal state	<b>Version</b>	<b>No explosion protection</b>
	No fault alarm	Conductive ( $R = 348 \Omega$ )
	Fault alarm	Effectively non-conducting
		<b>Ex</b>
		$\geq 2.2 \text{ mA}$
		$\leq 1.0 \text{ mA}$
Materials		
Housing	Die-cast aluminum EN AC-ALSi12(Fe) (EN AC-44300) acc. to DIN EN 1706 · Chromated and powder paint coated · Special version: stainless steel 1.4408	
External parts	Stainless steel 1.4404/316L	
Cable gland	M20 x 1.5, black polyamide	
Weight	Die-cast aluminum housing: approx. 1.0 kg Stainless steel housing: approx. 2.2 kg	





**Table 2:** Options for Type 3730-3 Positioner

Solenoid valve · Approval acc. to IEC 61508/SIL	
Input	24 V DC · Galvanically isolated and reverse polarity protection · Static destruction limit 40 V Current consumption $I = \frac{U - 5.7 \text{ V}}{3840 \Omega}$ (corresponding to 4.8 mA at 24 V/114 mW)
Signal '0' (no response)	<12 V (emergency venting at 0 V)
Signal '1' (response)	>19 V
Service life	>5 x 10 <sup>6</sup> switching cycles
K <sub>v</sub> coefficient	0.15
Analog position transmitter	
Auxiliary power	12 to 30 V DC · Reverse polarity protection · Static destruction limit 40 V
Output signal	4 to 20 mA
Operating direction	Reversible
Operating range	-10 to +114 %
Characteristic	Linear
Hysteresis	Same as positioner
High-frequency influence	Same as positioner
Other influences	Same as positioner
Fault alarm	Issued as status current 2.4 ±0.1 mA or 21.6 ±0.1 mA
Pepperl+Fuchs inductive limit contact	
SJ2-SN proximity switch	For connection to switching amplifier according to EN 60947-5-6. Can be used in combination with a software limit contact.
	Measuring plate not detected: ≥3 mA · Measuring plate detected: ≤1 mA
External position sensor	
Valve travel	Same as positioner
Cable	10 m · Flexible and durable · With M12x1 connector · Flame-retardant acc. to VDE 0472 Resistant to oils, lubricants and coolants as well as other aggressive media
Permissible ambient temperature	-40 to +90 °C with a fixed connection between positioner and position sensor · The limits in the test certificate additionally apply for explosion-protected versions
Immunity to vibration	Up to 10 g in the range of 10 to 2000 Hz
Degree of protection	IP 67
Leakage sensor · Suitable for operation in hazardous areas	
Temperature range	-40 to +130 °C
Tightening torque	20 ±5 Nm

<b>Binary input</b> · Galvanically isolated · Switching behavior configured over software (e.g. TROVIS-VIEW, DTM)	
Active switching behavior (default setting)	
Connection	For external switch (floating contact) or relay contact
Electric data	Open-circuit voltage when contact is open: max. 10 V Pulsed DC current reaching peak value of 100 mA and RMS value of 0.01 mA when contact is closed
Contact	Closed, R < 20 Ω
	Open, R > 400 Ω
	ON switching state (default setting)
	OFF switching state (default setting)
Passive switching behavior	
Connection	For externally applied DC voltage, reverse polarity protection
Electric data	3 to 30 V · Static destruction limit 40 V · Current consumption 3.7 mA at 24 V
Voltage	>6 V
	<1 V
	ON switching state (default setting)
	OFF switching state (default setting)
<b>Analog input x</b> · Galvanically isolated · Input for externally measured valve position	
Input signal	4 to 20 mA · Reverse polarity protection · Minimum span 6.4 mA
Electric data	Load impedance at 20 mA: 6.0 V · Impedance at 20 mA: 300 Ω · Overload capacity: 24 V AC/DC

**Table 3:** Summary of explosion protection approvals

Type	Certification			Type of protection/comments
-31		Number	PTB 02 ATEX 2174	II 2 G Ex ia IIC Gb II 2 D Ex ia IIIC T80°C Db II 2 D Ex tb IIIC T80°C Db
		Date	2017-02-14	
	<b>CCC Ex</b>	Number	2020322307001016	Ex ia IIC T4 ~ T6 Gb, Ex iaD 21 T80
		Date	2020-09-04	
		Valid until	2025-09-03	
	<b>CCoE</b>	Number	A/P/HQ/MH/104/6864	Ex ia IIC T6..T4 Gb Ex nA IIC T6 Gc
		Date	2021-08-30	
		Valid until	2025-12-31	
<b>IECEX</b>	Number	IECEX PTB 05.0008X	Ex ia IIC T6..T4 Gb; Ex ia IIIC T80°C Db	
	Date	2016-11-30		
	Number	RU C-DE.AA87.B.01278	1Ex ia IIC T6..T4 Gb; Ex ia IIIC T80°C Db; Ex tb IIIC T80°C Db	
	Date	2018-11-30		
	Valid until	2023-11-29		
<b>INMETRO</b>	No.	IEEx 13.0161X	Ex ia IIC T6/T5/T4 Gb, Ex ia IIIC T80 °C Db Ex tb IIIC T80 °C Db	
	Date	2019-08-28		
	Valid until	2022-08-27		
<b>NEPSI</b>	Number	GYJ17.1408X	Ex ia IIC T4~T6 Gb Ex iaD 21 T80	
	Date	2017-11-21		
	Valid until	2022-11-20		
<b>TR CMU 1055</b>	Number	ZETC/35/2021	II 2G Ex ia IIC T6...T4 Gb II 2D Ex ia IIIC T80 °C Db	
	Date	2021-07-26		
	Valid until	2024-07-25		
-33	<b>CSA</b>	Number	1330129	Ex ia IIC T6; Class I, Zone 0; Class I, Groups A,B,C,D; Class II, Groups E,F,G; Class I, Zone 2; Class I, Div.2 Groups A,B,C,D; Class II, Div.2 Groups E,F,G
		Date	2021-10-11	
	<b>FM</b>	Number	3012394	Class I, Zone 0 AEx ia IIC; Class I, II, III; Div. 1, Groups A, B, C, D, E, F, G; Class I, Div. 2, Groups A, B, C, D; Class II, III. Div. 2, Groups F, G
		Date	2011-08-11	

Type	Certification		Type of protection/comments		
-35		Number	PTB 02 ATEX 2174	II 2 D Ex tb IIIC T80°C Db	
		Date	2017-02-14		
	CCC Ex	Number	2020322307001016	Ex tD A21 IP 66 T80 °C	
		Date	2020-09-04		
		Valid until	2025-09-03		
IECEX	Number	IECEX PTB 05.0008X	Ex tb IIIC T80°C Db		
	Date	2016-11-30			
INMETRO	No.	IEx 13.0161X	Ex tb IIIC T80 °C Db Ex nA IIC T6 Gc, Ex tc IIIC T80 °C Dc,		
	Date	2019-08-28			
	Valid until	2022-08-27			
TR CMU 1055	Number	ZETC/35/2021	II 2D Ex tb IIIC T80 °C Db		
	Date	2021-07-26			
	Valid until	2024-07-25			
-38		Number	PTB 03 ATEX 2180 X	II 3G Ex nA II T6 Gc, II 3D Ex tc IIIC T80°C Db	
		Date	2016-06-30		
	CCC Ex	Number	2020322307001016	Ex nA IIC T4 ~ T6 Gc, Ex tD A22 IP66 T80 °C	
		Date	2020-09-04		
		Valid until	2025-09-03		
		Number	RU C-DE.AA87.B.01278	2Ex ic IIC T6...T4 Gc; 2Ex nA IIC T6...T4 Gc X; Ex tc IIIC T80°C Dc X	
		Date	2018-11-30		
		Valid until	2023-11-29		
	IECEX	Number	IECEX PTB 05.0008X	Ex nA IIC T6 Gc, Ex tc IIIC T80°C Dc	
		Date	2016-11-30		
NEPSI	Number	GYJ17.1408X	Ex ic IIC T4~T6 Gc; Ex nA IIC T4~T6 Gc; Ex tD A22 IP66 T80°C		
	Date	2017-11-21			
	Valid until	2022-11-20			
TR CMU 1055	Number	ZETC/35/2021	II 3G Ex ic nA IIC T6 Gc II 3D Ex tc IIIC T80 °C Dc IP66		
	Date	2021-07-26			
	Valid until	2024-07-25			
3730	-39		Number	PTB 03 ATEX 2211 X	II 2G Ex d[ia] IIC T6 Gb
			Date	2003-10-22	

1) EC type examination certificate

2) Statement of conformity

Refer to Data Sheet ► T 8379 for Ex d approvals of Type 3770 Field Barrier

## Mounting the positioner

The Type 3730 Electropneumatic Positioner can be attached directly to the Type 3277 Actuator (175 to 750 cm<sup>2</sup>) over a connection block. In actuators with "actuator stem extends" fail-safe action, the signal pressure is routed over an internal hole in the actuator yoke to the actuator. In actuators with "actuator stem retracts" fail-safe action, the signal pressure is routed to the actuator over ready-made external piping.

Using the appropriate bracket, the positioner can also be attached according to IEC 60534-6-1 (NAMUR recommendation). The positioner can be mounted on either side of the control valve.

A pair of universal brackets is used for the attachment to Type 3278 Rotary Actuators or other rotary actuators according to VDI/VDE 3845. The rotary motion of the actuator is transferred to the positioner over a coupling wheel with travel indication.

A special version of the positioner allows it to be attached according to VDI/VDE 3847. This type of attachment allows the positioner to be replaced quickly while the process is running by blocking the air in the actuator. The positioner can be attached directly to the Type 3277 Actuator using an adapter bracket or adapter block. Alternatively, it can be attached to the NAMUR rib of a control valve using an additional NAMUR connection block.

A reversing amplifier is necessary for double-acting, springless actuators for the second opposing signal pressure.

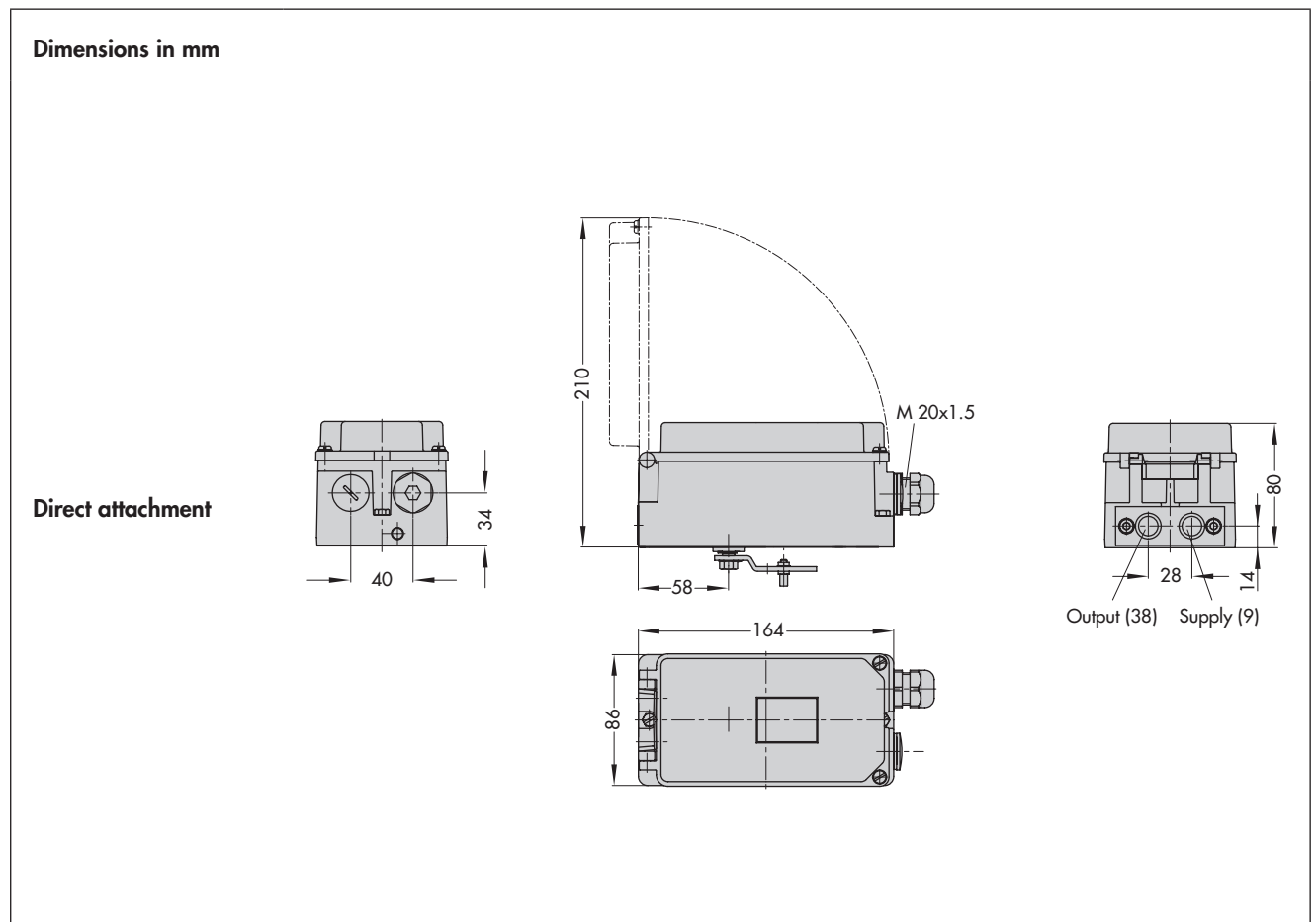

**NAMUR attachment**

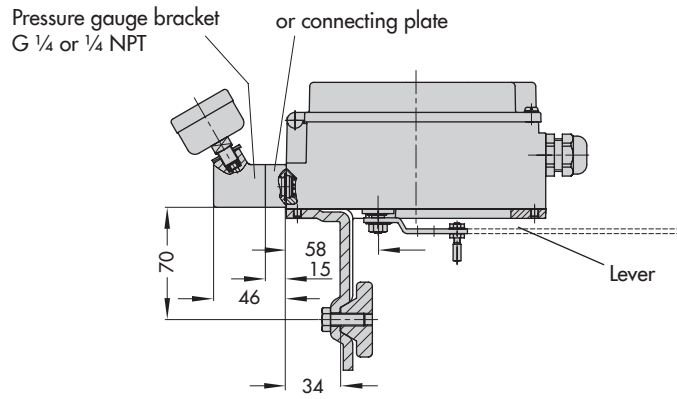

**Attachment according to VDI/VDE 3847**

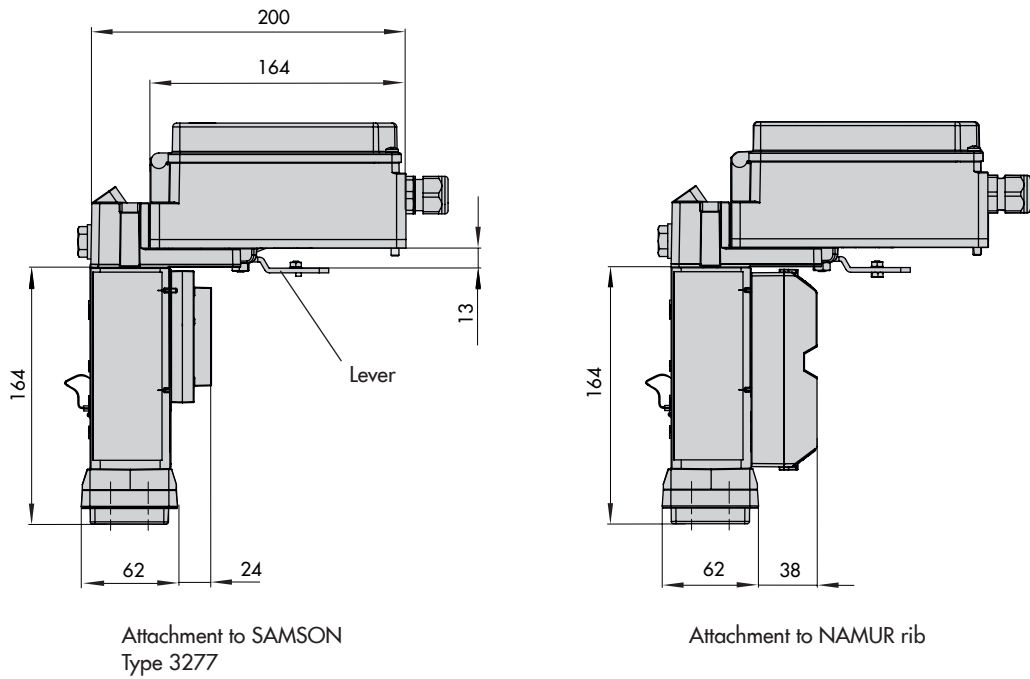

**External position sensor**

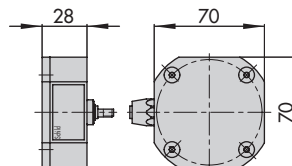

### Attachment to rotary actuators

VDI/VDE 3845 (Sept. 2010)

Fixing level 1

Size AA1 to AA4

#### Light version

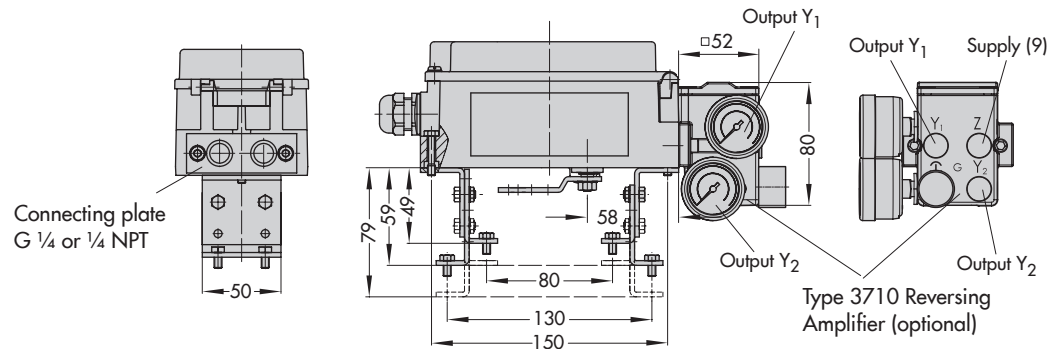

Mounting unit  
CrNiMo steel bracket

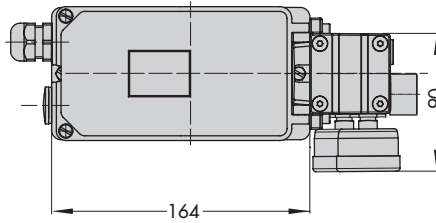

#### Heavy-duty version

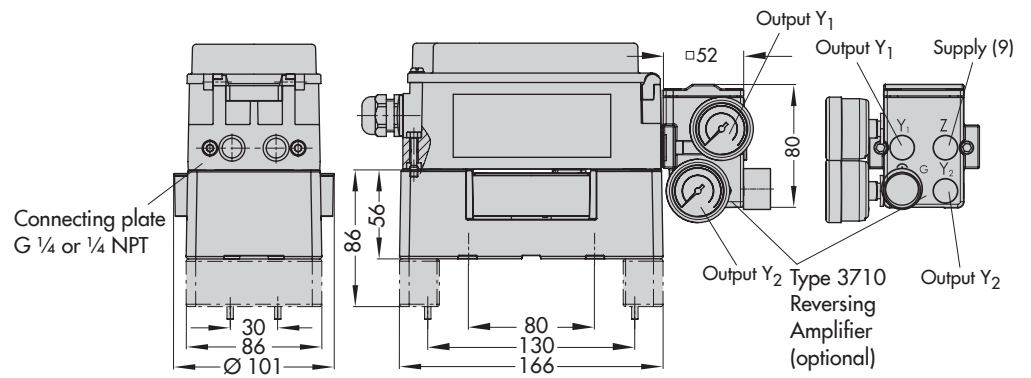

#### Lever

Lever	x	y	z
S	17 mm	25 mm	33 mm
M	25 mm	50 mm	66 mm
L	70 mm	100 mm	116 mm
XL	100 mm	200 mm	216 mm

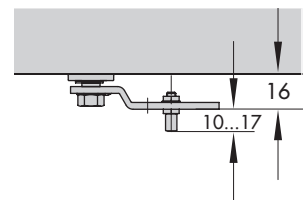
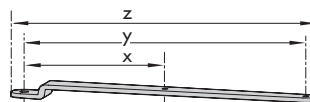

## Ordering text

### Type 3730-3... Positioner

- Without pneumatic connecting rail  
(only when directly attached to Type 3277)
- With pneumatic connecting rail ISO 228/1-G ¼
- With pneumatic connecting rail ¼-18 NPT
- Without/with pressure gauge up to max. 6 bar
- Attachment to Type 3277 Actuator (175 to 750 cm<sup>2</sup>)
- Attachment according to IEC 60534-6-1 (NAMUR)  
Valve travel: ... mm, if applicable, rod diameter: ... mm
- Attachment according to VDI/VDE 3847  
Valve travel: ... mm, if applicable, rod diameter: ... mm
- Attachment to Type 3278 Rotary Actuator (160/320 cm<sup>2</sup>),  
mounting unit with CrNiMo steel bracket or heavy-duty attachment
- Attachment to rotary actuators acc. to VDI/VDE 3845,  
mounting unit with CrNiMo steel bracket or heavy-duty attachment
- Pneumatic reversing amplifier for double-acting actuators  
with connection acc. to ISO 228/1-G ¼ or ¼-18 NPT
- Adapter M20x1.5 to ½ NPT
- Metal cable gland
- Special version: housing made of CrNiMo steel

**Article code**

Positioner	Type 3730-3	x	x	x	x	x	x	x	x	0	x	0	0	x	0	x	x
With LCD and autotune, HART® communication, 4 to 20 mA two software limit contacts, one fault alarm contact																	
<b>Explosion protection</b>																	
Without		0															
ATEX	II 2 G Ex ia IIC Gb; II 2 D Ex ia IIIC T80°C Db	1															
CSA	Ex ia IIC T6; Class I, Zone 0; Class I, Groups A, B, C, D; Class II, Groups E, F, G; Class I, Zone 2; Class I, Div.2, Groups A, B, C, D; Class II, Div.2, Groups E, F, G	3															
FM	Class I, Zone 0 AEx ia IIC; Class I, II, III; Div. 1, Groups A, B, C, D, E, F, G; Class I, Div. 2, Groups A, B, C, D; Class II, III. Div. 2, Groups F, G																
ATEX	II 2 D Ex tb IIIC T80°C Db	5															
ATEX	II 3G Ex nA II T6 Gc, II 3D Ex tc IIIC T80°C Db	8															
<b>Option (additional equipment)</b>																	
<b>Inductive limit contact</b>																	
Without			0														
SJ2-SN (NC contact)			1														
<b>Solenoid valve</b>																	
Without				0													
With, 24 V DC				4													
<b>Position transmitter</b>																	
Without					0												
With					1	0	0	0									
<b>External position sensor</b>																	
Without							0										
With			0			1					0						
Prepared connection			0			2											
Analog input x		0	0		0	3	0	0									
<b>Leakage sensor</b>																	
Without								0									
With					0	0	1	0									
<b>Binary input</b>																	
Without									0								
With					0	0	0	2									
<b>Diagnostics</b>																	
EXPERTplus										4							
<b>Housing material</b>																	
Aluminum (standard)											0						
Stainless steel					0						1						
<b>Special application</b>																	
Without																0	
Device completely free of paint-impairing substances																1	
Exhaust air with ¼ NPT connection, back of housing sealed																2	
With additional vent hole and VDI/VDE 3847 adapter, without travel pick-off parts																6	
With additional vent hole																7	
<b>Special version</b>																	
Without																	0 0
IECEx	Ex ia IIC T6...T4 Gb; Ex ia IIIC T80°C Db	1															1 2
	Ex tb IIIC T80°C Db	5															3 4
	Ex nA IIC T6 Gc; Ex tc IIIC T80°C Dc	8															1 3
EAC	1Ex ia IIC T6...T4 Gb; Ex ia IIIC T80°C Db; Ex tb IIIC T80°C Db	1															1 4
	2Ex ic IIC T6...T4 Gc; 2Ex nA IIC T6...T4 Gc X; Ex tc IIIC T80°C Dc X	8															2 0

