

Welded, Hermetically Sealed Load Cell

FEATURES

- Capacities 5–500 kg
- Stainless steel construction
- OIML R60 and NTEP approved
- IP68 protection
- **Optional**
 - EEx ia IIC T6 hazardous area approval
 - FM approval available



APPLICATIONS

- Low profile platforms
- Loss-in-weight feeders
- Marine and hybrid scales
- Belt weighers
- Food industry harsh environment

The low profile, high accuracy and sealing makes this load cell highly suitable for applications such as low profile platforms, weighing and packing machines, conversion of mechanical scales and variety of other applications where sealed cells are required. For hazardous environments this load cell is available with EEx ia IIC T6 level of approval as an option.

DESCRIPTION

Model 355 is a welded bending load cell manufactured in stainless steel. Hermetically sealed against moisture the Model 355 construction and polyurethane shielded cable enables the load cell to function in harsh environments while maintaining its operating specifications.

The two additional sense wires feed back the voltage reaching the load cell. Complete compensation of change in the lead resistance due to temperature change and/or cable extension, is achieved by feeding this voltage into the appropriate electronics.

OUTLINE DIMENSIONS in millimeters

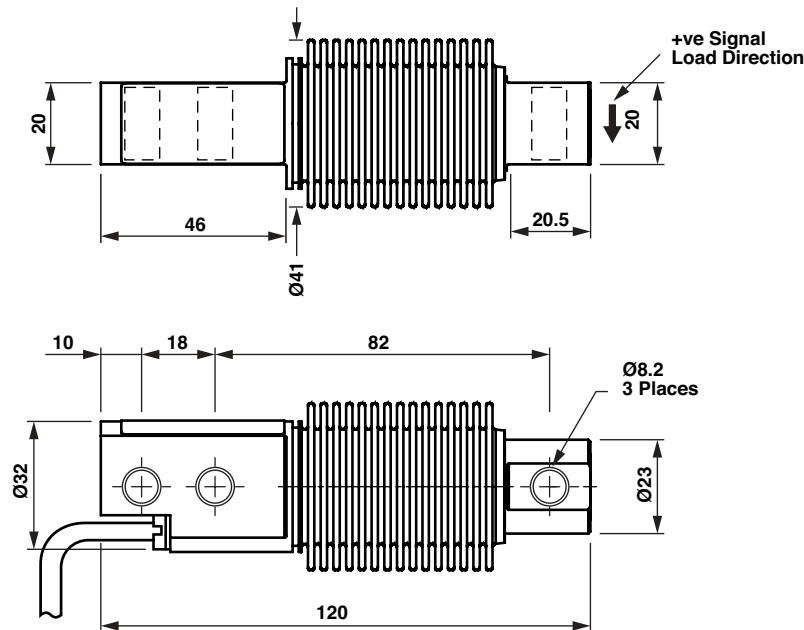

Welded, Hermetically Sealed Load Cell

SPECIFICATIONS					
PARAMETER	VALUE				UNIT
Rated capacity—R.C. (E _{max})	5, 10, 20, 30, 50, 100, 200, 250, 500				kg
NTEP/OIML accuracy class	NTEP	Non-Approved	C3 ⁽¹⁾	C4 ⁽²⁾	
Maximum no. of intervals (n)	4000 single	1000	3000	4000	
Y = E _{max} /V _{min}	5800	2000	15000	13333	Maximum available 15000
Rated output—R.O.	2.00 (UR matched = 2.02)				mV/V
Rated output tolerance	0.002				±mV/V
Zero balance	0.04				±mV/V
Zero return, 30 min.	0.0125	0.0500	0.0170	0.0125	±% of applied load
Total error	0.0200	0.05	0.0200	0.0150	±% of rated output
Temperature effect on zero	0.0023	0.007	0.0009	0.0011	±% of rated output/°C
Temperature effect on output	0.001	0.0040	0.0010	0.0008	±% of applied load/°C
Temperature range, compensated	-10 to +40				°C
Temperature range, safe	-20 to +70				°C
Maximum safe central overload	150				% of R.C.
Ultimate central overload	300				% of R.C.
Excitation, recommended	10				VDC or VAC RMS
Excitation, maximum	15				VDC or VAC RMS
Input impedance	380±10				Ω
Output impedance	355±5				Ω
Insulation resistance	>2000				MΩ
Cable length	3				m
Cable type	6-wire, braided, polyurethane, dual floating screen				Standard
Construction	Stainless steel				
Environmental protection	IP68				
Recommended torque	22.0				N*m

⁽¹⁾ 20% utilization

⁽²⁾ 30% utilization

All specifications subject to change without notice.

Wiring Schematic Diagram

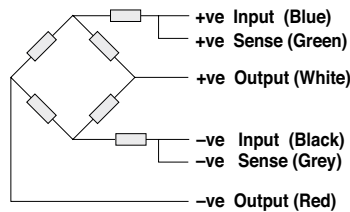

Disclaimer

ALL PRODUCTS, PRODUCT SPECIFICATIONS AND DATA ARE SUBJECT TO CHANGE WITHOUT NOTICE.

Vishay Precision Group, Inc., its affiliates, agents, and employees, and all persons acting on its or their behalf (collectively, "VPG"), disclaim any and all liability for any errors, inaccuracies or incompleteness contained herein or in any other disclosure relating to any product.

The product specifications do not expand or otherwise modify VPG's terms and conditions of purchase, including but not limited to, the warranty expressed therein.

VPG makes no warranty, representation or guarantee other than as set forth in the terms and conditions of purchase. **To the maximum extent permitted by applicable law, VPG disclaims (i) any and all liability arising out of the application or use of any product, (ii) any and all liability, including without limitation special, consequential or incidental damages, and (iii) any and all implied warranties, including warranties of fitness for particular purpose, non-infringement and merchantability.**

Information provided in datasheets and/or specifications may vary from actual results in different applications and performance may vary over time. Statements regarding the suitability of products for certain types of applications are based on VPG's knowledge of typical requirements that are often placed on VPG products. It is the customer's responsibility to validate that a particular product with the properties described in the product specification is suitable for use in a particular application. You should ensure you have the current version of the relevant information by contacting VPG prior to performing installation or use of the product, such as on our website at vpgsensors.com.

No license, express, implied, or otherwise, to any intellectual property rights is granted by this document, or by any conduct of VPG.

The products shown herein are not designed for use in life-saving or life-sustaining applications unless otherwise expressly indicated. Customers using or selling VPG products not expressly indicated for use in such applications do so entirely at their own risk and agree to fully indemnify VPG for any damages arising or resulting from such use or sale. Please contact authorized VPG personnel to obtain written terms and conditions regarding products designed for such applications.

Product names and markings noted herein may be trademarks of their respective owners.

Copyright Vishay Precision Group, Inc., 2014. All rights reserved.

Document No.: 63999 Revision: 15-Jul-2014