

Setup and Operation Instructions



INITIATING THE AUTOSET COMMAND

STEP 1— Position the effective UV light beam focused on the invisible fluorescent material and push the AUTOSET button. The reading will go to “8” on the Contrast Indicator.

STEP 2— Manually move the area with the invisible fluorescing agent out of view. The reading on the contrast indicator must go below 3 – the lower the reading the higher the contrast deviation.

It is recommended that a minimum contrast deviation of 7 or 8 be obtained to provide a reasonable operating safety margin. Please note that if the signal level fails to reach 7 to 8 when operating during the AUTOSET routine, it is advisable to move closer to the surface and repeat the AUTOSET. It may be necessary to peak the signal level by moving the sensor up or down, searching for the position that achieves the maximum signal level as displayed on the contrast indicator with the UV fluorescent material in view.

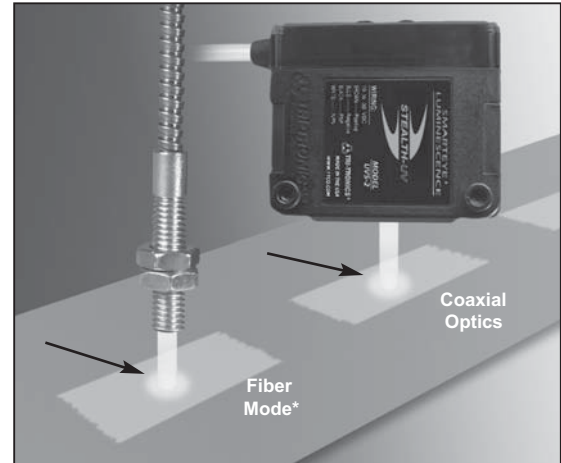

UV fluorescent agent glows when excited by ultraviolet light.

CONTRAST INDICATOR

CONTRAST INDICATOR BAR 8
Remains illuminated when light-state signal strength is 8 or above.

SWITCHPOINT BAR 4
Sensor outputs toggle or switches state when the signal level passes above and below bar 4.

CONTRAST INDICATOR BAR 1
Extinguishes when dark state signal strength is below bar 1.

Responds to invisible fluorescent UV materials

TIMER INDICATOR
Color green illuminates when the 15 millisecond pulse stretching timer is enabled. Push both buttons simultaneously to enable/disable the timer.

OUTPUT INDICATOR
Color red illuminates when the output transistors are in the “on” state.

MANUAL UP ADJUST BUTTON
Used to “tweak” setting if needed.

LIGHT/DARK TOGGLE
Push button for two seconds to toggle the output.

MANUAL DOWN ADJUST BUTTON
Use to “tweak” setting if needed.

AUTOSET
Push button for one second with fluorescent surface in view.



Model/Range Guidelines

Optimal range is dependent upon fluorescent concentration, size, and surface reflectivity.

NOTE: Sensor selection should not be determined solely by range. It may be advisable to test multiple sensors or fiber optic light guide tip configurations to ensure optimum performance.

COAXIAL

UVS-1

Focal Distance 0.50" (12.7 mm)
 Spot Size 0.067" (1.7 mm)
 Usable Range 0 to 5.0"
 (0 to 127 mm)
 Response Time 200 microseconds

UVS-2

Focal Distance 1.0" (25.4 mm)
 Spot Size 0.086" (2.2 mm)
 Usable Range 0 to 7.5"
 (0 to 190.5 mm)
 Response Time 200 microseconds

CONVERGENT

UVS-5

Focal Distance 8.0" (203 mm)
 Spot Size 1.0" (25.4 mm)
 Usable Range 2.0 to 24.0"
 (50.8 to 609.6 mm)
 Response Time 750 microseconds

UVS-3

Focal Distance 2.0" (50.8 mm)
 Spot Size 0.128" (3.25 mm)
 Usable Range 0 to 10.0"
 (0 to 254 mm)
 Response Time 200 microseconds

UVS-4

Focal Distance 4.0" (101.6 mm)
 Spot Size 0.16" (4.1 mm)
 Usable Range 0 to 13.0"
 (0 to 330 mm)
 Response Time 200 microseconds

FIBER OPTIC

UVS-6

Micro Polished Fiber Optic Light Guide
 BF-U-36TUV 0.156" Bundle Size
 Usable Range Up to 2.5" (63.5 mm)
 Response Time 350 microseconds

SPECIFICATIONS

SUPPLY VOLTAGE

- 10 to 30 VDC
- Polarity Protected

CURRENT REQUIREMENTS

- UVS-1, UVS-2, UVS-3, UVS-4: 50 milliamps
- UVS-5, UVS-6: 65 milliamps (exclusive of load)

OUTPUT TRANSISTORS

- (1) NPN and (1) PNP output transistor:
 NPN: Sink up to 150 milliamps
 PNP: Source up to 150 milliamps
- Continuous short circuit protected
- Outputs protected from pulsing during power up

RESPONSE TIME

- Varies by sensor model

LIGHT IMMUNITY

- Responds to sensor's pulse modulated light source ... immune to most ambient light and strobes, including indirect sunlight

RUGGED CONSTRUCTION

- Chemical resistant high impact polycarbonate housing, acrylic lens cover
- Industry Ratings: NEMA 4, IP67

AMBIENT TEMPERATURE

- -40°C to +70°C
 (-40°F to 158°F)

PUSH BUTTON CONTROL

- "One-Touch" AUTOSET™ push-button setup
- Tweak adjustments with "up" or "down" buttons
- Selection of Light/Dark operation
- Enable/Disable pulse stretcher

HYSTERESIS

- 2 bars as displayed on Contrast Indicator:
 Light State switch = 5
 Dark State Switch = 3

DIAGNOSTIC INDICATORS

- Contrast Indicator – Display scaled reading of sensor's response to contrasting light levels (light vs. dark) on an 8 bar LED display
- RED LED OUTPUT INDICATOR
 Illuminates when the sensor's output transistors are "on"
- GREEN LED TIMER INDICATOR
 Illuminates when the 15 millisecond pulse stretcher timer is enabled

Product subject to change without notice.

Connections and Dimensions

SMARTEYE® STEALTH-UV

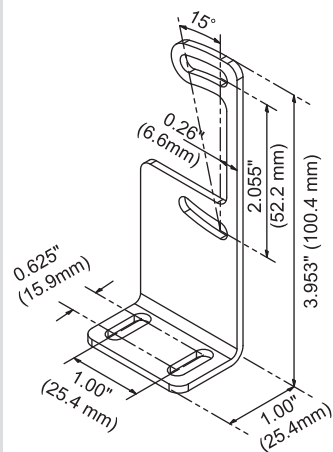

SEB-4 Mounting Bracket With Hardware

4 Pin 12 mm Male Micro Connector

