

TSUBAKI TERVO REDUCER for SERVO MOTOR

Instruction Manual



- Thank you for purchasing Tsubaki's TERVO Reducer. This is a high-quality sophisticated unit, which should be handled only by experienced engineers.
- To ensure you obtain optimum life from the unit, read and understand the entire contents of this manual prior to operation.
- This manual should be considered an essential part of the reducer and remain with the reducer when redistributed.
- To ensure safe operation, this manual must be accessible to every user.

TSUBAKIMOTO CHAIN Co.



Table of Contents

Safety Precautions

1. Upon Receiving Your Reducer
 - 1-1. Verifying Your Order
 - 1-2. Inquiries
 - 1-3. How to Read the Nameplate
2. Transportation
3. Motor installation to reducer
 - 3-1. Keyed Motor Shaft (Sleeve Coupling Type)
 - 3-2. Round Motor Shaft (Clamp Type Input Hollow Shaft)
 - 3-3. Keyed Motor Shaft Installation to Clamp Type Input Hollow Shaft
4. Installation
 - 4-1. Ambient Conditions
 - 4-2. General Installation
 - 4-4. Connecting to Equipment
5. Lubrication
 - 5-1. GMTK and HMTK
 - 5-2. TMMK, SW(J)MK and EW(J)MK
6. Precautions for Daily Inspection and Maintenance
 - 6-1. Precautions for Maintenance
 - 6-2. Maintenance
 - 6-3. Abnormal Conditions
 - 6-4. Oil Seals
7. Assembly and Disassembly
8. Storage
9. Others
10. Disposal
11. Trouble Shooting
12. Warranty
 - 12-1. Warranty Period without Charge
 - 12-2. Warranty Coverage
 - 12-3. Warranty with Charge
13. Disclaimer

<Safety Precautions>

Safety precautions in this manual are classified into two categories: WARNING and CAUTION. These categories are defined as follows.

 WARNING	Death or serious injury may result from misusing the product without following the instructions under this label.
 CAUTION	Minor to moderate injury and damage to the product may result from misusing the product without following the instructions under this label.

Note that there is a possibility that an item listed under CAUTION may result in serious injuries.



<General>

- Transporting, installing, wiring, maintaining or inspecting must be carried out by skilled and professional engineers. Otherwise, explosion, electrical shock, injury or damage to the unit may result.
- When the reducer is used for a passenger vehicle, install a suitable protection device on the vehicle. This can prevent accidents and equipment damage.
- When the reducer is used for an elevator, install a safety device on the elevator in order to protect it from falling over. Otherwise, accidents resulting in death, injury or equipment damage may occur.
- Only TSUBAKIMOTO CHAIN engineers should overhaul the reducer, for it requires specific skills.

<Transportation>

- Never stand under the product when it is lifted for transportation. Otherwise, the product may fall and cause major accidents resulting in death or injury.

<Operation>

- Never stand close to the rotating parts (ie. shafts) to avoid possible injuries.

<Daily Inspection and Maintenance>

- Avoid contact with rotating parts such as the shaft while carrying out maintenance or inspection. Rotating parts can catch body parts and cause injuries.
- Do not unplug the pressure vent during operation because hot oil may splash and cause burn injuries.
- Verify that the drive and driven shafts are completely stopped prior to inspecting gear teeth. Failure to do so may result in accidents.
- Do not overload the reducer. Doing so may damage the unit and shorten gear life.



CAUTION

<General>

- Do not use the reducer beyond the capacity specified on the nameplate or specification sheet. Otherwise, explosion, electrical shock, injury or equipment damage may result.
- Do not insert fingers or other objects into the reducer opening. Otherwise, electrical shock, injury, fire or equipment damage may result.
- Do not use a damaged reducer as this may cause fire or injury.
- Do not remove the nameplate.
- Problems caused by your attempts to remodel the product are not covered by our warranty, and are therefore, not held responsible by TSUBAKIMOTO CHAIN.

<Upon Receiving Your Reducer>

- Be sure the product delivered matches your order. This will prevent you from accidents, injuries or equipment damage caused by installing the wrong unit.
- Be sure the package is in its upright position prior to opening.

<Transportation >

- When transporting your equipment, take caution so that it does not fall or overturn. When using lifting rings, make sure they are securely fastened. After the reducer is installed to another equipment however, do not lift the entire system using these rings. Otherwise, injuries and equipment damage may result from defected lifting rings.
- Be sure the weight of the reducer, based on the diagram and catalog provided, does not exceed the maximum rate assigned to the lifting device. Otherwise, the device may break and damage the equipment.
- If the reducer is packed in a wooden case, it may not be appropriate for a fork lift transportation. Secure the package with belt straps if fork lifting is necessary.

<Installation and Connection>

- Do not place flammables in the vicinity of the reducer. Otherwise, fire or other such accidents may occur.
- Never place any obstacles that block the ventilation around the reducer. Overheating can cause burns, fire and other accidents.
- Never climb or hang from the reducer to avoid possible injury.
- Do not touch the shaft key with bare hands to avoid possible injury.
- When the reducer is used for a food processing machine, use an oil pan to prevent oil leaks caused by equipment failure or end of life. Lubricant oil can damage food or other such products and your equipment.

<Connecting to Equipment>

- When you connect the reducer to your equipment, pay attention to centering, belt tension, and pulley parallelism. Be sure to connect accurately for direct coupling. When using a belt-drive, make sure to tighten the belt to proper tension. Before operation, verify that the pulley and coupling bolts are securely fastened. Otherwise, injury or damage to the equipment may result from broken pieces of the equipment.
- Install covers to prevent access to any rotating parts.
- Before connecting to a machine, check the direction of the reducer rotation. Incorrect direction of rotation may cause injuries or equipment damage.

<Operation>

- If the reducer is run independently, remove the temporary key attached to the output shaft.
- Make sure the motor is completely stopped before reversing the direction of rotation. Failure to do so may result in damaged reducer or equipment.
- The surface temperature of the reducer increases considerably during operation. Do not touch the reducer so as to prevent burn injuries.
- Stop operation immediately upon suspecting any trouble. This can prevent possible electrical shock, injury or fire.
- Do not exceed the rated load. Otherwise, injury or equipment damage may result.
- Do not loosen oil plugs or pressure vents during operation. Otherwise, hot oil may splash and cause burn injuries.

< Daily Inspection and Maintenance >

- Follow the lubrication instructions provided in this manual. Not using the recommended lubricants may cause physical damage to the reducer, and reduce its life and capacity.
- Diagnose a problem based on the instructions provided in this manual. Never resume an operation until the cause of the problem is investigated.

<Assembly and Disassembly>

- Only skilled engineers should repair, disassemble or assemble the reducer. Otherwise, electrical shock, injury or fire may occur.

< Scrapping >

- Dispose the reducer and lubricant as general waste.

【 1 】 Upon Receiving Your Reducer

1-1. Verifying your order

Be sure to verify the following before using the product. Should you find any problems with the unit delivered, contact your distributor or TSUBAKIMOTO CHAIN.



CAUTION

- Be sure the product delivered matches your order. This will prevent you from accidents, injuries or equipment damage caused by installing the wrong unit.
- Be sure the package is in its upright position prior to opening.

- (1) The model number and gear ratio on the nameplate correspond to your request.
- (2) No damage has been done to the product during transportation.
- (3) Bolts and screws are snugly in place.

1-2. Contacting TSUBAKIMOTO CHAIN

When you are reporting an incorrect model number or gear ratio on the nameplate, or if you are ordering replacement parts or another product, contact your distributor or TSUBAKIMOTO CHAIN with the following information.

- (1) Manufacturing or test number of the said product.
- (2) Model number and type.
- (3) Drawing number

1-3. How to read the nameplate

Model No. of TERVO

S W M K 8 0 T 3 0 LF □□□□ - K
 ① ② ③ ④ ⑤ ⑥ ⑦

①Type	HMTK	Hypoid Gearhead
	GMTK	Helical Gearhead
	SW(J)MK	Worm Gearhead
	EW(J)MK	
	TMMK	
②Frame	HMTK	0220 0222 0228 0230 0428 0430 0435 0438 0735 0738 0742 0745 1542 1545 1550 1555 2242 2245 2250 2255
	GMTK	0218 0224 0228 0424 0428 0438 1538 1542 1550 2242 2250 2263
	SW(J)MK	35 42 56 70 80 100 (125)
	EW(J)MK	50 63 70 80 100 (125)
	TMMK	10 13 16
	③Mounting/ Installation	HMTK
	GMTK	L : Foot U : Face F : Flange
	SW(J)MK	T : Output Horizontal, Input Top B : Output Horizontal, Input Bottom
	EW(J)MK	V : Vertical E : Free
	TMMK	
④Gear Ratio	Example	3 0
⑤Shaft Arrangement	HMTK	S T
	SW(J)MK	LF RF DF
	EW(J)MK	L R LR LU LD LUD RU RD RUD
	TMMK	A B C
⑥Mounting Code	□□□□	Already registered the code on motor manufacturer, model, etc..
⑦Option	HMTK	K : With POWER-LOCK
	SW(J)MK	K : With POWER-LOCK
		T B ** : Taper Bushing Note : ** shows Shaft Diameter

【 2 】 Transportation

 **WARNING**

<Transportation>

- Never stand under the product when it is being lifted for transportation. Otherwise, the product may fall and cause major accidents resulting in death or injury.

 **CAUTION**

< Transportation >

- When transporting your equipment, take caution so that it does not fall over. When using lifting rings, make sure they are securely fastened to the equipment. After the reducer is installed to another equipment, however, do not lift the entire system using these rings. Otherwise, injuries and equipment damage may occur from defected lifting rings.

- Be sure the weight of the reducer, based on the nameplate, drawing and catalog provided, does not exceed the maximum rate assigned to the rings. Otherwise, the device may break and damage the equipment.
- If the reducer is packed in a wooden case, it may not be appropriate for a fork lift transportation. Secure the package with belt straps if fork lifting is necessary.

When transporting the reducer, insert eyebolts in the casing tap holes and suspend with care.

【 3 】 Motor Installation

 **CAUTION**

- Take caution so that the oil seal is not damaged from preliminary installation.
- Make sure to accurately center the motor shaft and reducer input shaft.
- Make sure to grease keyed motor shafts.
- Make sure to wipe off grease from round motor shafts.
- Do not hit the reducer and the motor with a tool such as a hammer, or insert the motor by tightening the bolts. Excessive force applied to the reducer and the motor may cause damage to the bearings or produce a loud noise.
- Be sure to tighten the bolts upon confirming that the motor is correctly installed.

3-1. Keyed Motor Shafts (Sleeve Coupling Type)

- (1) Install the reducer so that the motor mounting surface faces up.
- (2) Wipe off dust, rust, and rust prevention oil from the motor shaft and reducer.
- (3) Grease the motor shaft to prevent burns.
- (4) Align the motor output shaft key with the reducer input hollow shaft keyway accurately.
- (5) Carefully insert the motor output shaft into the reducer input hollow shaft.
- (6) After verifying that the motor and reducer flange grooves are completely intact, secure the reducer onto the motor flange by tightening appropriate bolts to their applicable torque.

a. Greasing

The reducer input hollow shaft bore is factory greased to prevent burns. Apply some of this grease to the motor shaft, and then mount the motor. If reassembling, use a molybdenum grease to prevent burns.

b. Installing a Key Sleeve Coupling

Slide a Key Sleeve coupling onto the motor shaft and secure by tightening the setscrews with a hexagonal wrench. Then, mount the motor to the reducer.

3-2. Round Motor Shafts (Clamp Type Input Shafts)

- (1) Install the reducer so that the motor mounting surface faces up.
- (2) Wipe off dust, rust, and rust prevention oil from the motor shaft and reducer.
- (3) Remove the flange setscrew, and then turn the input hollow shaft to align the bolt heads with the positions of the setscrew. Using an L spanner, verify that the set bolts are loosened.
- (4) Carefully and smoothly insert the motor shaft into the input hollow shaft. Take caution so that you do not insert the motor shaft at an angle.
- (5) After the key has been snugly fitted into the keyway grooves, secure the reducer onto the motor flange by tightening appropriate bolts to their applicable tightening torque.
- (6) Using a torque wrench, tighten the clamp bolts set on the input shaft to the torque specified in tables 3-1 and 3-2.
- (7) Tighten the setscrew to complete the motor installation.

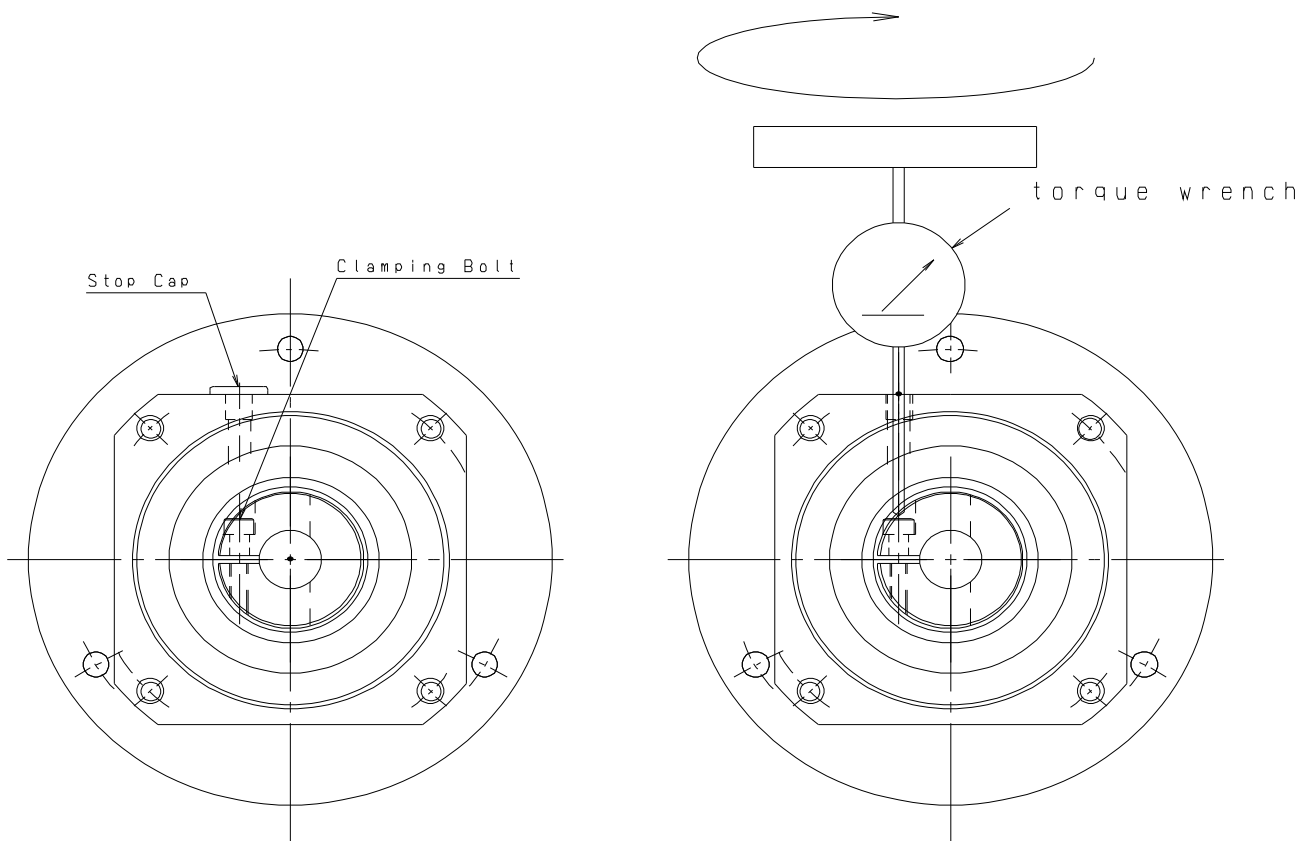

Table 3-1 Tightening Torque for GMTK/HMTK Clamp Set Bolts

GMTK Size	HMTK Size	Set Bolt Size	Tightening Torque
0218U/L 0224U/L 0228U/L	0230H 0228U	M4	4.1N·m (0.41kgf·m)
0424U/L 0428U/L 0438U/L	0430H 0428U 0435H 0438U		
0728U/L 0738U/L 0742F/L	0735H 0738U 0745H 0742U	M5	8.5N·m (0.85 kgf·m)
1538U/L 1542F/L 1550F/L	1545H 1542U 1555H 1550U		
2242F/L 2250F/L 2263F/L	2245H 2242U 2255H 2250U	M6	14N·m (1.42 kgf·m)

Table 3-2-1 SW(J)MK/EW(J)MK/TMMK Clamp Set Bolt Size

Worm Model No.	Mounting Code	E4□C	G2□C/G5□C	J4□C	K2□C/K3□C/K4□C	L1□C
	Groove Circumference	φ 50G7	φ 70G7	φ 95G7	φ 110G7	φ 114.3G7/H7
	Mounting Pitch	PCD70	PCD90	PCD115	PCD145	PCD200
TMMK10		M3	—	—	—	—
TMMK13/SWJMK35/EWJMK35		M3	M3	—	—	—
TMMK16/SWJMK42/EWJMK42		M3	M3	—	—	—
SWMK56		M3	M4	M4	—	—
SWJMK50/EWJMK50		—	M4	M4	—	—
SWJMK63/EWJMK63/SWJMK70		—	M4	M4	M6	M6
EWJMK70		—	—	M4	M6	M6
SWMK80/EWMK80		—	—	—	M6	M6
SWMK100/EWMK100		—	—	—	—	M6

Table 3-2-2.SW(J)MK/EW(J)MK/TMMK Clamp Set Bolt Tightening Torque

Clamp Set Bolt Size	Tightening Torque
M3	1.9N·m (0.19kgf·m)
M4	3.8N·m (0.39kgf·m)
M6	12 N·m (1.22kgf·m)

3-3. Installing a Clamp Type Input Hollow Shaft with Keyed Motor

Like the round shafts, keyed motor shafts can be used as a clamp type by removing the key. However, you must align the slit in the clamp portion with the keyway in the servo motor shaft as in the diagram below.

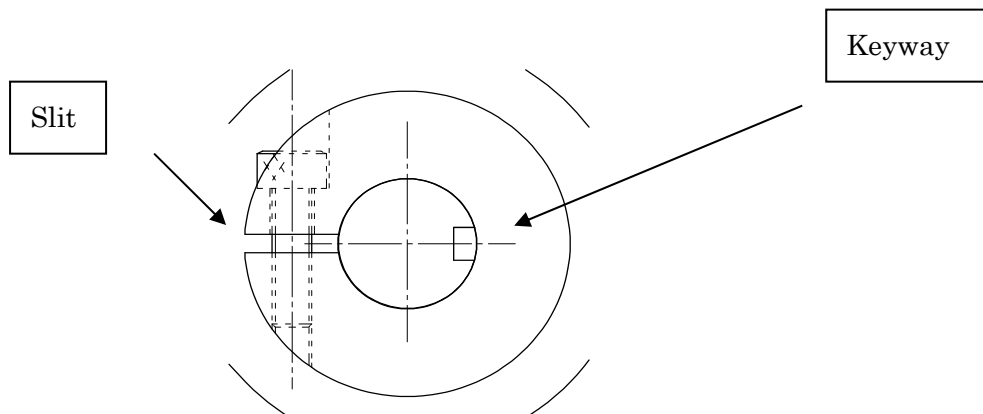

【 4 】 Installation

WARNING

- Do not place any flammables in the vicinity of TERVO Reducer. Otherwise, fire may occur.
- Never place obstacles that block the ventilation around the reducer. The unit may overheat and cause burn injuries, fires and other accidents.
- Do not climb or hang from the reducer. Doing so may result in accidents
- Do not touch the reducer shaft and keyway with bare hands. Failure to do so may cause injuries.
- Provide oil pans for food manufacturing machines to prevent oil from leaking into food products, should the machines experience a mechanical failure or end of life cycle.

4-1. Installation Environment

1. Ambient Temperature: 0~40 ° C
2. Humidity: 85% or greater
3. Altitude: Below 1000m
4. Atmosphere: Free of flammables, explosives and vapor. A well-ventilated space with no dust.

4-2. Installation

Fitting insufficient lengths of mounting bolts or tightening them with excessive torque may damage the tap holes. On the other hand, if the torque is too small, the entire unit assembly may loosen due to the shocks experienced from repeated starting and stopping.

Screw Size	Hexagonal Bolt		Hexagonal Head Cap Screw	
	N · m	{Reference : kgf · m}	N · m	{References : kgf · m}
M 8	9.8~10.3	{1.0~1.05}	9.8~19.6	{1.0~2.0}
M 1 0	19.6~20.6	{2.0~2.1}	19.6~39.2	{2.0~4.0}
M 1 2	34.3~36.3	{3.5~3.7}	34.3~68.6	{3.5~7.0}
M 1 6	84.3~88.2	{8.6~9.0}	84.3~168.6	{8.6~17.2}

Note) When mounting a flange to a GMTK Face Mount Type (U), be sure to use the bolts and conical spring washer provided.

4-3. Connecting to an Equipment

CAUTION

- When loading the reducer, pay attention to pulley parallelism, belt tension and concentricity. If directly connecting to your equipment, take caution in the connection accuracy. If using a belt, be sure to adjust to appropriate tension. Before operation, verify that the pulley and coupling bolts are securely fastened. Otherwise, injury or damage to the equipment may result from broken pieces of the equipment.
- Use covers to prevent access to rotating parts. Failure to do so may result in injuries.
- Verify the direction of motor rotation prior to equipment connection. Incorrect direction of motor rotation may lead to accidents.

(1) Foot Mount and Face Mount Types

Hitting a sprocket or gear during installation may damage the output shaft bearing. For phase adjustments, try Tsubaki Power-Locks. Center belt and chain accurately, and make sure any overhang load does not exceed the rated value.

a. Foot Mount Type

- Installation must be carried out on a level surface that is strong enough to withstand vibrations. Verify that the reducer mounting-surface is clean. Then, using the attached four bolts, secure the reducer to the installation surface.
- In the case of using a coupling, be sure to align the shafts accurately. Misalignments may cause loud noise and vibrations and may also reduce the lives of bearing, gear, and shaft.
- Chains and belts should also be centered accurately and pulled to appropriate tension so that excessive overhang load will not apply to the output shaft.

b. Face Mount Type

- Use the case tap holes to directly mount the reducer to your equipment.
- In the case of using a coupling, be sure to accurately align the shafts. Misalignments may cause loud noise and vibrations and may also reduce the lives of bearing, gear, and shaft.
- Chains and belts should also be centered accurately and pulled to appropriate tension so that excessive overhang load will not apply to the output shaft.

(2) Installing and Removing a Hollow Shaft

a. Mounting to Driven Shaft

- Grease the driven shaft and then insert into hollow shaft.
- When the shaft does not slide in smoothly, lightly tap with a soft hammer. Take caution so that you do not damage the casing and oil seal during this procedure. Using the below jigs may simplify the procedure.

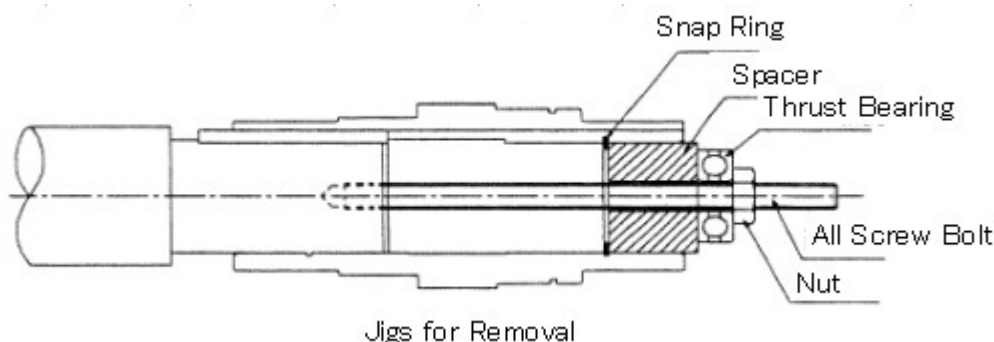

- Use a parallel key (JIS B1301-1976). Using an angled key or that with a head will affect the shaft alignment and reduce equipment life or cause physical damage.

(3) Mounting to Driven Shaft

Be sure to mount the reducer to driven shaft.

(1) Mounting Methods

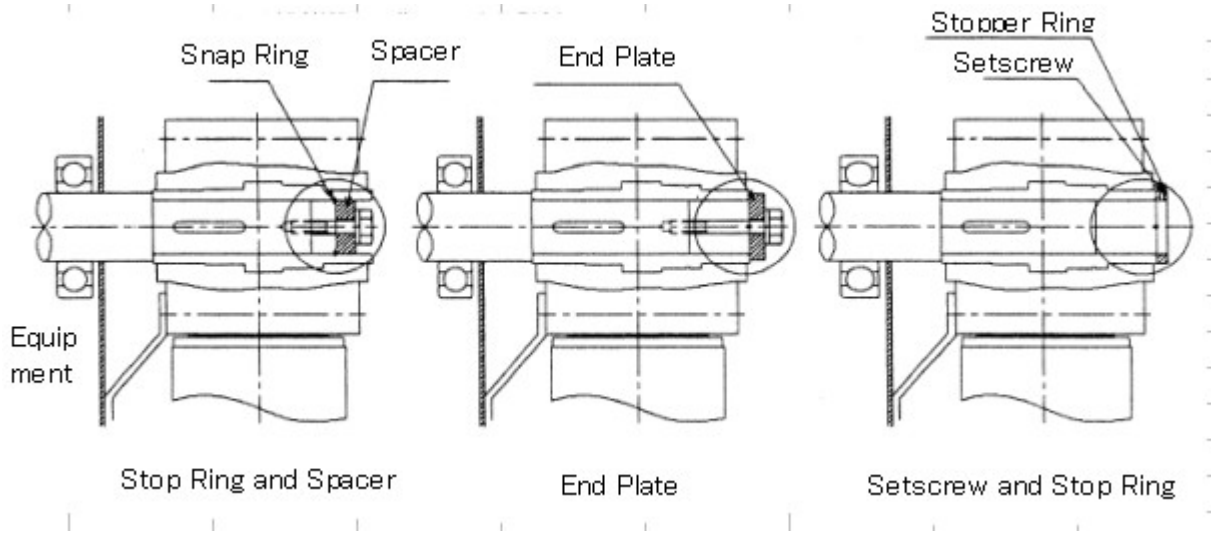
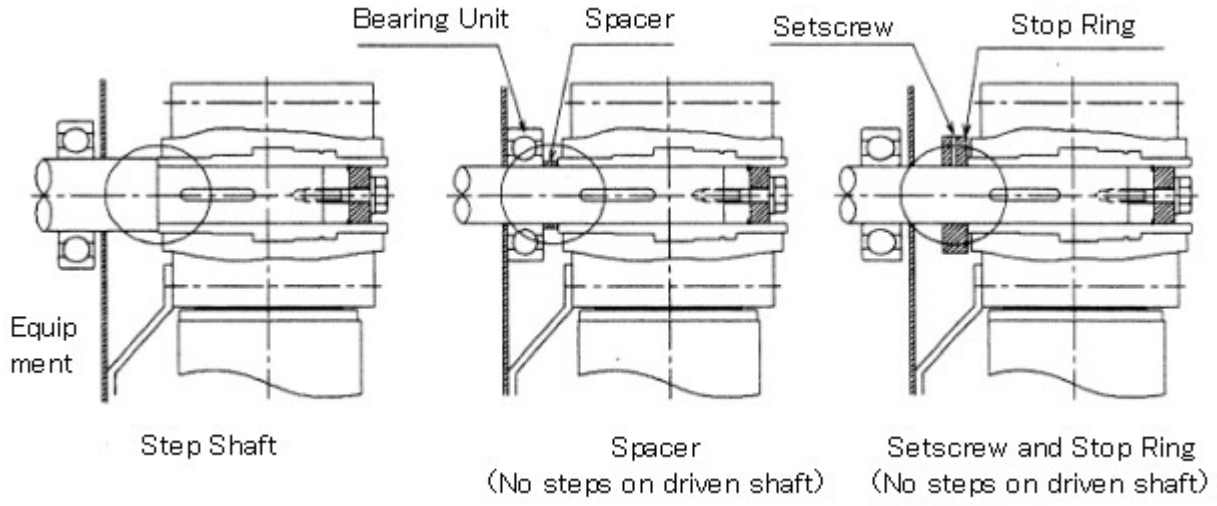

(4) Torque Arm Rotation Prevention

Install a torque arm after determining the appropriate reducer mounting method (position). Pay attention so that the reducer and the driven shaft do not rotate together during this process. Provide enough leeway between the reducer and the driven shaft in the rotation prevention portion of the arm, so that they will not rotate together. Do not fix the torque arm with a rotation prevention bolt.

(5) Removing from a Driven Shaft

Remove driven shaft from hollow shaft, without applying too much force between the casing and the hollow shaft. Using the jigs below will allow a smooth removal.

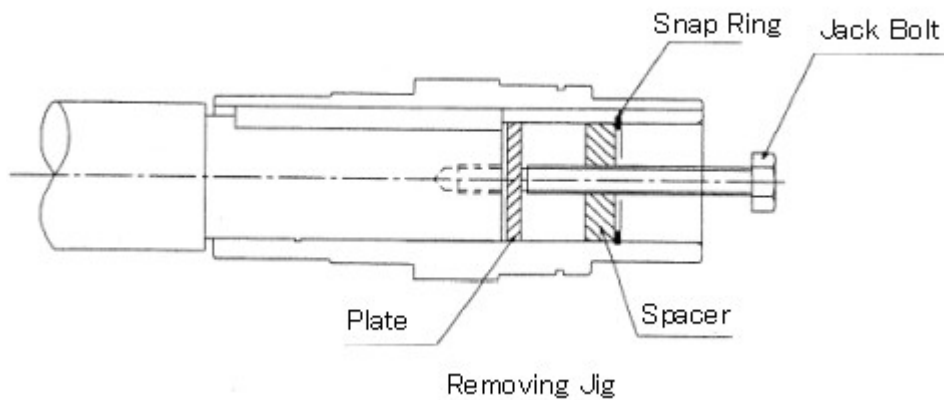

【 5 】 Lubrication



CAUTION

- Change lubrication according to the instruction manual. Use only the lubrication recommended. Other kinds of lubrication may damage your equipment.
- Do not lubricate the reducer during or immediately after operation. Doing so may cause burn injuries.
- Dispose lubrication as general waste.

5-1. GMTK and HMTK

(1) Grease Lubrication

Your reducer is factory lubricated with Nippon Grease Nigtite LMS No.000. Replace with No.000 or No.00 high quality gear grease accordingly, at the next lubrication interval.

(2) Grease Quantity in Kilograms

GMTK	
Model No.	Grease Quantity
0 2 1 8	0. 1 4
0 2 2 4	0. 3 0
0 2 2 8	0. 5 0
0 4 2 4	0. 3 0
0 4 2 8	0. 5 0
0 4 3 8	1. 1 0
0 7 2 8	0. 5 0
0 7 3 8	1. 1 0
0 7 4 2	1. 3 0
1 5 3 8	1. 3 0
1 5 4 2	1. 4 0
1 5 5 0	2. 8 0
2 2 4 2	1. 3 0
2 2 5 0	2. 8 0
2 2 6 3	4. 2 0

HMTK			Grease Quantity
Model No.	(Gear Ratio)		
0 2 2 0	0 2 2 2	(1 / 5 ~ 1 / 2 5)	0. 2 7
0 2 2 0	0 2 2 2	(1 / 3 0 ~ 1 / 6 0)	0. 2 3
0 2 2 8	0 2 3 0		0. 3 3
0 4 2 8	0 4 3 0		0. 3 3
0 4 3 5	0 4 3 8		0. 5 3
0 7 3 5	0 7 3 8	(1 / 5 ~ 1 / 3 0)	0. 6 7
0 7 3 5	0 7 3 8	(1 / 4 0 ~ 1 / 5 0)	0. 5 3
0 7 4 2	0 7 4 5		1. 1 5
1 5 4 2	1 5 4 5	(1 / 5 ~ 1 / 3 0)	1. 4 0
1 5 4 2	1 5 4 5	(1 / 4 0 ~ 1 / 8 0)	1. 1 5
1 5 5 0	1 5 5 5		3. 8 0
2 2 4 2	2 2 4 5	(1 / 5 ~ 1 / 2 0)	1. 4 0
2 2 4 2	2 2 4 5	(1 / 2 5 ~ 1 / 6 0)	1. 1 5
2 2 5 0	2 2 5 5		3. 8 0

(3) Greasing Intervals

In most cases, additional greasing is not required. However, replacing the grease after 20,000 hours of operation will further extend the reducer life.

5-2. TMK, SW(J)MK and EW(J)MK

(1) Oil Lubrication

Your reducer is factory lubricated with Daphne alpha oil TE260. To lubricate EWMK 80 ~ EWMK 125 and SWMK80 ~ SWMK 125 be sure to use the attached pressure vent and apply only the specified oil. Proper lubrication is critical to reducer power, life and efficiency. Do not mix lubrication oils.

(2) Oil Quantity in Liters

Model Type		TMMK 1 0	TMMK 1 3	TMMK 1 6
Mounting Position	E	0. 0 8	0. 1 7	0. 2 9

Model Type		SWJMK35	SWJMK42	SWJMK50	SWMK56	SWJMK70
Mounting Position	E	0. 1 0	0. 1 6	0. 5 5	0. 6 8	1. 3

Model Type		SWMK80	SWMK100	SWMK125
Mounting Positions	B	1. 0	1. 4	2. 2
	T	1. 8	2. 8	5. 1
	V	1. 4	2. 1	3. 7

Model Type		EWJMK50	EWJMK63	EWJMK70	EWMK80	EWMK100	EWMK125
Mounting Positions	E & B & T	0. 5	0. 9	1. 0	1. 2	1. 7	3. 1
	E & V				1. 7	2. 8	4. 8

(3) Oil Change Intervals

Oil change is not necessary for TMMK, SWJMK 35~70, and EWJMK 50~70. However, change the oil if severe oil deterioration cannot be avoided due to certain operation conditions. Oil change intervals for SWMK80~125 and EWMK80~125 are as follows.

- a. The first oil change should be carried out after 1,000 hours of operation.
This will remove all the abrasion powder generated by the initial contacts of parts and will improve performance and increase life.
- b. From the second time and thereafter, change oil every 5,000 hours of operation.
If oil performance decreases (change in viscosity, color etc.) shorten the intervals as needed.

(4) Operation Temperature

After the first 2~3 days of operation, the unit will normally under go a considerable temperature rise. However, if the casing surface temperature of EW(J)MK and SW(J)MK models exceed 100 ° C and that of TMMK exceed 93 ° C, the reducer may not have enough capacity for the operation or its lubrication may be insufficient. In this case, stop the operation immediately and investigate the problem.

【 6 】 Maintenance Precautions (Inspections and Adjustments)



WARNING

- Avoid contact with rotating parts such as the shaft while carrying out maintenance or inspection. Rotating parts can catch body parts and cause injuries.
- Do not unplug the pressure vent during operation because hot oil may splash and cause burn injuries.
- Verify that the drive and driven shafts are completely stopped prior to inspecting gear teeth. Failure to do so may result in accidents.
- Do not overload the reducer. Doing so may damage the unit and shorten gear life.



CAUTION

- Change lubrication according to the instruction manual. Use only the lubrication recommended. Other kinds of lubrication may damage your equipment.
- Touching the reducer surface with bare hands may cause burn injuries.
- Do not lubricate the reducer during or immediately after operation. Doing so may cause burn injuries.
- Handle troubles according to the instruction manual. Be sure to stop the operation and do not resume until the cause of the trouble has been identified.
- Repair, disassembly and assembly must be carried out by certified engineers.

6-1. Maintenance Precautions

To conduct maintenance:

- (1) Dress appropriately and wear safety glasses, gloves and shoes where necessary.
- (2) Clean the surrounding area to prevent secondary accidents.
- (3) Turn off the power and make sure that your equipment has completely stopped.
Take caution so that the power does not reconnect accidentally.
- (4) Touching the reducer during operation may cause burn injuries.
- (5) Observe the Labor Safety & Hygiene Regulations, General Criteria, Paragraph 1, Chapter 1, Edition 2, or your local regulations.

6-2. Maintenance

In general, the reducer may be maintained just by using your common sense and simple tools.

For example, keep your senses alert for the following indicators of abnormal conditions:

Noise: A clattering or strange noise.

Vibration: Abnormal vibration patterns.

Temperature: Abnormal increase in temperature.

Oil Leak: Oil leaks from oil seal, cover portion and between the contact surfaces of the reducer unit.

6-3. Handling Abnormal Conditions

Upon noticing any abnormal conditions, stop operation immediately. If the cause to such failure cannot be determined, contact the CS Center at TSUBAKIMOTO CHAIN.

6-4. Oil Seal

Operation conditions such as temperature will affect oil seal life and characteristics. You must replace oil seal if it is causing leaks. Use an oil pan or a similar device for food processing machines to prevent oil from leaking into food products.

【 7 】 Disassembly and Assembly



CAUTION

● Repair, disassembly and assembly must be carried out by certified engineers. Otherwise, electrical shock, injury and fire may result.

Contact TSUBAKIMOTO CHAIN if disassembly of the unit is required.

【 8 】 Storage Requirements

If you are not operating your TERVO Reducer immediately upon purchase, store under the following conditions.

8-1. Storage Space

Store in clean and dry space. Do not store outdoors where humidity, dust and corrosive gas may be present. Also, do not expose the unit to extreme temperature fluctuations.

8-2. Storage Direction

The unit is delivered in a package that is appropriate for the specific mounting style. Store with the package in the upright position. In the case of special mounting, take caution so that the grease and oil in the bearing portion do not mix and start to melt.

8-3. Storage Period

- (1) The reducer may be stored up to 6 months.
- (2) Storage over 6 months may require a special anti-rust treatment.

8-4. Operation after Storage

- (1) Non-metallic parts, such as oil seal, oil gage and oil plug are relatively easily affected by environmental factors such as temperature and UV rays. Before operating the product after a prolonged period of storage, inspect these parts to make sure that they function properly. If not, replace with new parts.
- (2) Also, check that there are no abnormal noise, vibration and heat prior to operating the unit. Contact TSUBAKIMOTO CHAIN CS Center or your distributor in times of product failure.

【 9 】 Others

For units with special specifications, refer to the drawings while observing the instructions provided in this manual. Should you need further information in regards to your special specifications model, contact TSUBAKIMOTO CHAIN CS Center.

【10 】 Disposal

 CAUTION
●Dispose TERVO Reducer lubrication grease and oil as general waste.

【 11 】 Trouble Shooting Trouble Shooting Chart

Trouble	What to Inspect	Action
Motor does not run under unloaded condition.	Gear, shaft and bearing	Carry out professional inspection
Motor does not run when the unit is loaded	Wear of gear	Carry out professional inspection
Abnormal increase in temperature	Bearing	Replace
Loud noise	Continuous noise: bearing and gear	Carry out professional inspection
	Intermittent noise: gear or foreign objects inside the unit.	Carry out professional inspection
Excessive vibration	Gear and bearing	Carry out professional inspection
	Incomplete mounting, loosened bolts	Retighten
Oil leak	Loosened bolts	Retighten
	Oil seal	Replace

【 12 】 Warranty:

TSUBAKIMOTO CHAIN Co.: hereinafter referred to as “Seller”

Customer: hereinafter referred to as “Buyer”

Goods sold or supplied by Seller to Buyer: hereinafter referred to as “Goods”

1. Warranty period without charge

18 months effective the date of shipment or 12 months effective the first use of Goods, including installation of Goods to Buyer’s equipment or machine—whichever comes first.

2. Warranty coverage

Should any damage or problem with the Goods arise within the warranty period, given that the Goods were operated and maintained under instructions provided in the manual, Seller would repair and replace at no charge. This warranty does not cover the following:

- 1) Any costs related to removal of Goods from the Buyer’s equipment or machine to repair or replace parts.
- 2) Cost to transport Buyer’s equipment or machine to the Buyer’s repair shop.
- 3) Costs to reimburse any profit loss due to any repair or damage and consequential losses caused by the Buyer.

3. Warranty with charge

Seller will charge any investigation and repair of Goods caused by:

- 1) Improper installation by failing to follow the instruction manual.
- 2) Insufficient maintenance or improper operation by the Buyer.
- 3) Incorrect installation of Goods into other equipment or machine.
- 4) Any modifications or alterations of Goods by the Buyer.
- 5) Any repair by engineers other than the Seller or those designated by the Seller.
- 6) Operation in an inappropriate environment not specified in the manual.
- 7) Force Majeure or forces beyond the Seller’s control such as natural disaster and injustices done by a third party.
- 8) Secondary damage or problem incurred by the Buyer’s equipment or machine.
- 9) Defected parts supplied or specified by the Buyer.
- 10) Wear, tear or deterioration of parts including bearings and oil seal.
- 11) Losses or damages not liable to the Seller

【 13 】 Disclaimer

- 1) In our constant efforts to improve, TSUBAKIMOTO CHAIN may change the contents of this document without notice.
- 2) Considerable effort has been made to ensure that the contents of this document are free from errors. However, TSUBAKIMOTO CHAIN makes no warranties with respect to the accuracy of information described herein. In the mean time, we would appreciate comments or reports on any inaccuracies or omissions in regards to this document to help us make amendments as necessary. Your cooperation is greatly appreciated.