

# unidirectional pump - series XV

**XV-OP**

**STANDARD PUMP**  
**ø22 FLANGE - PARALLEL SHAFT**

**X 0 P 06 02 A B B A**

Series	X	series XV
Group	0	group 0
Category	P	unidirectional pump
Displacement	06	0.76
Flange	02	Ø22 right rotation
Shaft	A	CI001 - Parallel ø7 - M7x1 - key thk. 2
Body	IN	inlet - 1/4" GAS
	OUT	outlet - 1/4" GAS
Cover	A	standard



**XP001**

**Technical data table**

TYPE	Displacement cm3/rev	Max. Pressure		CODE	
		P1 bar	P3 bar	Left rotation	Right rotation
XV-OP/0.17	0,16	220	260	X 0 P 01 01 A B B A	X 0 P 01 02 A B B A
XV-OP/0.25	0,24	220	260	X 0 P 02 01 A B B A	X 0 P 02 02 A B B A
XV-OP/0.45	0,45	220	280	X 0 P 04 01 A B B A	X 0 P 04 02 A B B A
XV-OP/0.57	0,56	220	280	X 0 P 05 01 A B B A	X 0 P 05 02 A B B A
XV-OP/0.76	0,75	220	280	X 0 P 06 01 A B B A	X 0 P 06 02 A B B A
XV-OP/0.98	0,92	220	280	X 0 P 07 01 A B B A	X 0 P 07 02 A B B A
XV-OP/1.27	1,26	220	280	X 0 P 09 01 A B B A	X 0 P 09 02 A B B A
XV-OP/1.52	1,48	220	280	X 0 P 11 01 A B B A	X 0 P 11 02 A B B A
XV-OP/2.30	2,28	190	210	X 0 P 13 01 A B B A	X 0 P 13 02 A B B A

P1) Max. working pressure - P3) Max. peak pressure

For heavy-duty applications, it is recommended to check the admissible torque of the shaft

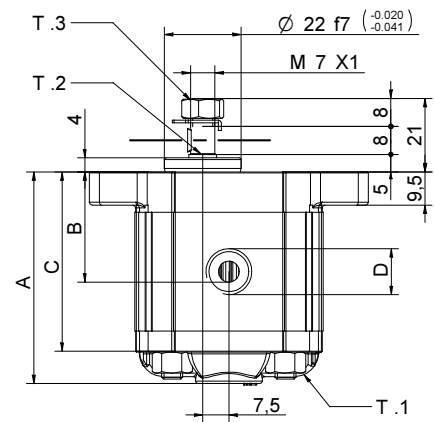
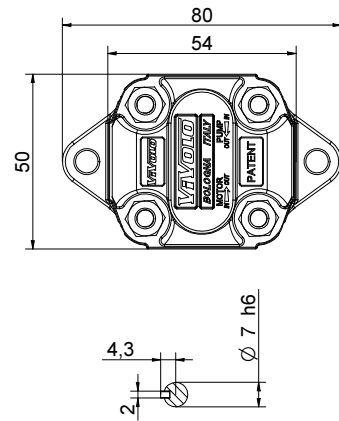

**Dimensions table**

TYPE	Weight kg	A	B	C	D	D
		mm	mm	mm	IN	OUT
XV-OP/0.17	0,400	55,8	26,2	46,8	1/4" BSPP	1/4" BSPP
XV-OP/0.25	0,410	56,4	26,5	47,4	1/4" BSPP	1/4" BSPP
XV-OP/0.45	0,420	58,0	27,3	49,0	1/4" BSPP	1/4" BSPP
XV-OP/0.57	0,430	59,0	27,8	50,0	1/4" BSPP	1/4" BSPP
XV-OP/0.76	0,440	60,5	28,5	51,5	1/4" BSPP	1/4" BSPP
XV-OP/0.98	0,460	62,0	29,3	53,0	1/4" BSPP	1/4" BSPP
XV-OP/1.27	0,480	64,5	30,5	55,5	1/4" BSPP	1/4" BSPP
XV-OP/1.52	0,500	66,5	31,5	57,5	1/4" BSPP	1/4" BSPP
XV-OP/2.30	0,560	72,5	34,5	63,5	1/4" BSPP	1/4" BSPP

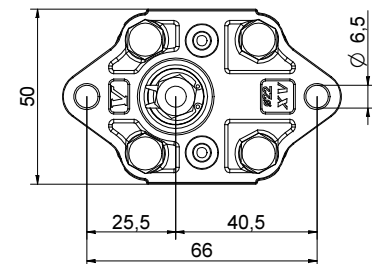

07/12/04 XOP0602ABBA.dft

T.1 = 11.7÷13.7 [Nm] - screw tightening torque M6

T.3 = 11.5 [Nm] - torque wrench setting 11

T.2 = 2.1 [Nm] - admissible shaft torque (N.B. When choosing a shaft, always check the admissible torque).

# Table of variations

**XV-OP**

## Standard ø22 FLANGE

Standard ø22 FLANGE				Shaft				Cover			
Left rotation		Right rotation						Left rotation		Right rotation	
	<b>01</b>		<b>02</b>	CI001 - Parallel T.2 = 2.1 [Nm]	<b>A</b>	CF001 - Milled shank T.2 = 9.2 [Nm]	<b>B</b>			<b>A</b>	
	<b>03</b>		<b>04</b>	CF005 - Milled shank T.2 = 8.4 [Nm]	<b>F</b>	CO001 - Tapered T.2 = 21.9 [Nm]	<b>E</b>			<b>B</b>	
	<b>05</b>		<b>06</b>							<b>C</b>	
	<b>07</b>		<b>08</b>							<b>D</b>	

Displacement	
TYPE	CODE
XV-0P/0.17	<b>01</b>
XV-0P/0.25	<b>02</b>
XV-0P/0.45	<b>04</b>
XV-0P/0.57	<b>05</b>
XV-0P/0.76	<b>06</b>
XV-0P/0.98	<b>07</b>
XV-0P/1.27	<b>09</b>
XV-0P/1.52	<b>11</b>
XV-0P/2.30	<b>13</b>

Standard bodies				
Displacement cm <sup>3</sup> /rev	Standard threads			
	0.17	B - B	Z - B	Z - Z
0.25	B - B	Z - B	Z - Z	
0.45	B - B	Z - B	Z - Z	
0.57	B - B	Z - B	Z - Z	
0.76	B - B	Z - B	Z - Z	
0.98	B - B	Z - B	Z - Z	
1.27	B - B	Z - B	Z - Z	
1.52	B - B	Z - B	Z - Z	
2.30	B - B	Z - B	Z - Z	

Table showing standard flange and thread combinations available in stock

		<b>N</b>
Internal drainage		
		<b>O</b>
External drainage		

Body (threads/flanges)													
	<b>A</b>		<b>B</b>		<b>C</b>		<b>D</b>		<b>E</b>		<b>F</b>		<b>G</b>
	<b>H</b>		<b>I</b>	<b>Closed Body</b>		<b>Z</b>							