

DNFT-PRG-PS

P/N: 000519

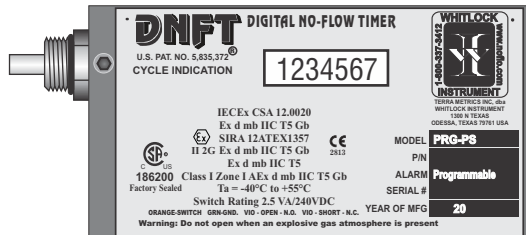

DNFT-PRG-PS

- MONITORS MOVEMENT OF DIVIDER VALVE PISTON FOR DEPENDABLE "TIMED" SHUTDOWN PROTECTION
- CLOSED LOOP OR OPEN LOOP OPERATION
- INSTALLS DIRECTLY TO DIVIDER VALVE
- NOT AFFECTED BY TEMPERATURE OR OIL VISCOSITY
- REQUIRES NO EXTERNAL POWER
- FIELD REPLACEABLE BATTERY
- LED INDICATOR AND LCD DISPLAY
- PRG IS PROGRAMMABLE TO DISPLAY: TOTAL PINTS
- PINTS PER DAY PUMP RATE TOTAL DIVIDER VALVE CYCLES
- CYCLE TIME OF DIVIDER VALVE
- PROGRAMMABLE ALARM TIME
- DEDICATED SWITCH CLOSURE TO MONITOR
- EACH DIVIDER VALVE CYCLE (PS OPTION)

SPECIFICATIONS

Temperature Range.....	-40°C to +55°C
Switch Rating.....	2.5VA/240 VDC
PRX Rating.....	2.5VA/240 VDC/0.5A
Epoxy Encapsulated.....	UL LISTED EL-CAST VFR 641
Power.....	Field Replaceable Lithium Battery
	3.6 Volt, 1.5 Ah, 75mA MAX Contentious Current
Alarm/Shutdown.....	Programmable - 20 sec to 4 min 15 sec alarm
Battery.....	P/N 000505
Divider Block Application.....	SBCO/Lubriquip/Lincoln/Dropsa
Warranty.....	2.5 Years

WARRANTY RATINGS

IECEX CSA 12.0020
SIRA 12ATEX1357
II 2G Ex d mb IIC T5 Gb
Ex d mb IIC T5
Class I Zone I A Ex d mb IIC T5 Gb
Ta = -40°C to +55°C
Switch Rating 2.5 VA/240VDC
PRX 2.5 VA/200VDC MAX/0.5mA

DESCRIPTION

The DNFT-PRG-PS is a totally enclosed electronic device, combining the latest technology in microprocessor and transistor components for detecting Slow-Flow and No-Flow of divider block lubrication systems. The DNFT incorporates an oscillating crystal to accurately monitor the cycle time of the lubrication system to enable precisely timed shutdown capability. The magnet assembly and control housing mount directly to the divider valve to become an integral part of the lubrication system. The DNFT-PRG operates on field replaceable lithium battery. If battery voltage drops below normal operating levels, the DNFT goes into alarm mode and the unit cannot be restarted. The PRG utilizes a LED to indicate each cycle of the divider valve. This enables the operator to easily set and monitor lubrication rates. The PRG comes with a liquid crystal display to display total pints, cycle time of divider valve, total cycles of divider valve, and pints per day pump rate. The PRG can easily be programmed for an alarm time from 20 seconds to 4minutes 15 seconds. The DNFT has been designed and rated for use in Class I Zone I environments, to be used outdoors in wet or dry locations, in altitudes under 2000 meters, with a Pollution Degree of 4.

OPERATION

Lubricant flow through the divider valve assembly forces the pistons to cycle back and forth causing a lateral movement of a magnet linked to the piston. Movement is monitored by the microprocessor which resets the timer, lights the LED, and allows the unit to continue operation. This indicates one complete cycle of the lubrication system. The microprocessor must receive this cycle in a predetermined time or a shutdown will occur. The DNFT will automatically reset alarm circuit when normal operation of divider valve resumes.

Distributed by:

TROUBLESHOOTING DNFT-PRG

NOTICE: WHEN MORE THAN ONE DNFT IS INSTALLED ON THE COMPRESSOR OR ENGINE, EACH DNFT MUST BE WIRED TO A SEPARATE ALARM CIRCUIT ON THE CONTROL PANEL, ANNUNCIATOR OR PLC TO SIMPLIFY TROUBLESHOOTING THE LUBRICATION SYSTEM AND DNFT.

PROBLEM	POSSIBLE CAUSE	SERVICE PROCEDURE AND / OR CORRECTION
1. LED does Not Blink, Control Panel Indicates Lube No-Flow (See also, 3.Erratic shutdown)	A. Improperly Adjusted	Loosen set screws, slide DNFT all the way onto hex of magnet housing and torque to 25 inch pounds max.(Do not over tighten) Cycle divider valve by pumping clean oil through system with lubrication system purge gun or running compressor. If necessary, adjust DNFT 1/16" back until LED blinks or LCD changes with each cycle of divider valve
	B. Spring or Magnet is Broken in Magnet Assembly	Loosen set screws, remove DNFT from magnet housing. Remove magnet assembly from divider valve. Remove magnet, spacer and spring. Check components for damage. Replace damaged spring or magnet and install on divider valve. If necessary, adjust DNFT, check for LED blink or number change on LCD. Purge air from system with lubrication system purge gun.
	C. Bent Magnet Housing	Loosen set screws, remove DNFT from magnet housing. Check for damaged or bent magnet housing. Remove magnet assembly from divider valve. Replace magnet housing, magnet, spring and spacer. Re-install DNFT on magnet housing. If necessary, adjust DNFT, check for LED blink or number change on LCD. Purge air from system with lubrication system purge gun.
2. No Display on LCD	A. Low Battery voltage B. Defective LCD	Remove the battery from the DNFT per the attached instructions. Replace the battery if the voltage is below 2.5 volts using a factory recommended replacement battery.
3. After installation of DNFT, Rupture Disc is Blown and Divider Valve is Locked up.	A. Wrong Magnet Housing Installed on Divider Valve (See magnet assy. Below)	Loosen set screws, remove DNFT from magnet housing. Check for correct magnet housing for divider valve manufacturer. Remove and replace with correct magnet housing. If necessary, adjust DNFT, check for LED blink or number change on LCD. Purge air from system with lubrication system purge gun.
	B. Air or Debris in Divider Valve System.	Check system pressure to insure oil is flowing to divider valves. If necessary install pressure gauge to monitor operation of lubrication system. 1. <u>Loosen</u> outlet plugs in front of valve blocks. Fast purge the system with lubrication system purge gun until clean, clear, air free oil appears from plugs. 2. <u>Loosen</u> each piston enclosure plug individually to purge air from behind piston Do not remove piston enclosure plugs. Tighten all divider valve plugs. Adjust DNFT. <u>To insure proper operation of the divider block lubrication system, it is absolutely necessary that all tubing and components be filled with oil and free of air before start-up.</u>
Electrical Testing of PRG		1. NORMALLY OPEN - Attach ohmmeter to orange wires, violet wires should be insulated from each other. Ohmmeter should read 10 ohms or less in alarm state 2. NORMALLY CLOSED - Attach ohmmeter to read red wires. Violet should be shorted together. Ohmmeter should read infinity in alarm mode
C. Faulty Lube Pump		Check system pressure to insure oil is flowing to divider valve. If necessary, install pressure gauge to monitor operation of lubrication system. Check gauge to insure pump will build sufficient pressure to inject oil into cylinder. You cannot check for oil flow into cylinder by removing tubing from check valve and pumping oil to atmosphere. Replace pump.

TYPICAL DNFT INSTALLATION

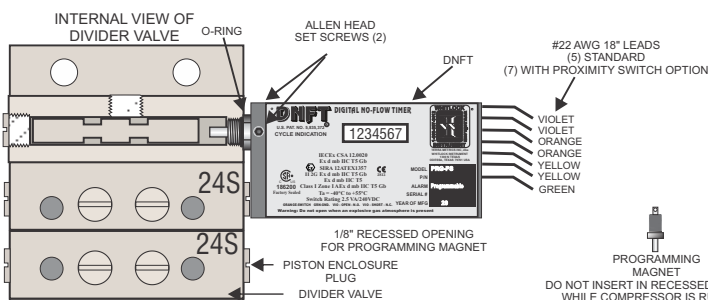

Magnet Assemblies and Applications

DNFT must be installed with correct magnet assembly for each divider valve manufacturer.

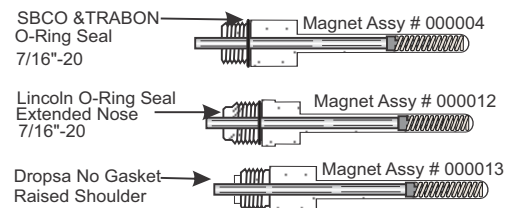

CAUTION: DISCONNECT ALL WIRING PRIOR TO WELDING ON COMPRESSOR OR SKID.

DNFT

DIGITAL NO-FLOW TIMER



Name: PRG Literature
 Date of Revision: 16AUG2022
 Revision: 1.6
 Created By: AR / Approved by: RG
 File: PRG_LIT
 Rev Change: Updated Markings

P/N 000519 DNFT-PRG-PS PROGRAMMABLE DIGITAL NO-FLOW TIMER WITH DEDICATED PROXIMITY SWITCH. INSTALL ON TRABON* DIVIDER BLOCK WITH O-RING SEALS. SWITCH RATING 2.5VA / 240VDC

NOTICE: DNFT-PRG MUST BE PROGRAMMED BEFORE INSTALLING ON DIVIDER VALVE (SEE PROGRAMMING INSTRUCTIONS)

- Loosen all Allen head set screws (A) on DNFT (B) and remove magnet housing (C). Do not remove magnet, spring or spacer from magnet housing.
- Remove piston enclosure plug (D) from end of divider valve where DNFT will be installed. The DNFT does not have to be installed on the top divider valve. It may be installed on any convenient divider valve, top to bottom. (**Notice:** Do not install DNFT on Lincoln divider valves with cycle indicator pins or any Dropsa divider valve less than SMX 16.)
- Be sure O-ring (F) is in place on magnet housing (C). Screw magnet housing (C) into end of divider valve (E). Torque to 15 foot pounds max.
- Slide DNFT (B) all the way onto hex of magnet housing (C). Tighten set screws on hex of magnet housing. Torque 25 inch pounds max.
- If number on LCD (G) does not change, or LED does not blink, DNFT must be adjusted. Before adjusting DNFT, divider valve must be cycling with compressor running or by manually pumping oil into the divider valve. **Notice:** The self-check circuitry indicates normal operation and battery voltage by a continuous faint blink of the LED. Normal cycle indication is a bright strobe type blink.
- Adjustment is made by sliding the DNFT (B) all the way on the hex of the magnet housing (C). Tighten set screws on hex of the magnet housing to 25 inch pounds max. If there is no change on the LCD or the LED does not blink, adjust the DNFT back in 1/16" increments. Correct adjustment of the DNFT is confirmed by number change on the LCD or the LED blinking.
- All conduit and connections should be appropriate for area classification. **Notice:** Conduit and fittings must be supported to avoid bending magnet housing.
- After installing magnet assembly and pre-compressor start-up, it is absolutely necessary to purge all air from divider block lubrication system. This can easily be accomplished with a lubrication system purge gun.**
- DNFT must be installed with correct magnet assembly for each divider valve manufacturer.
 - Lincoln-7/16"-20 extended nose with O- ring
 - Trabon-1995 and later 7/16"-20 with O-ring
 - Dropsa

TYPICAL DNFT INSTALLATION

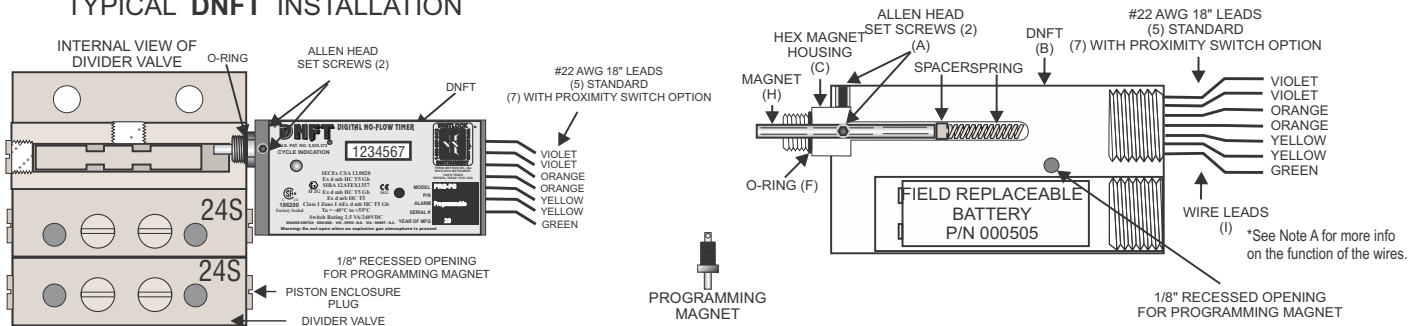

Notice: When installing more than one DNFT, each DNFT must be wired to a separate alarm circuit of the control panel, annunciator, or PLC to simplify troubleshooting the lubrication system and DNFT.

NOTE: The DNFT shall be installed in such a way that there is a low risk of mechanical danger.

Warning: DO NOT OPEN when an explosive gas atmosphere is present.

***NOTE A:**

Output Alarm Wires: The orange alarm wires are used to connect the DNFT to a PLC, annunciator, or other control monitoring device. The alarm wires will open or close, depending on which wires are used, to indicate a fault in the lubrication system.

Device Operation Wires: The violet wires control the Normally Open or Normally Closed operation of the alarm wires. Violet wires Isolated = N.O. Violet wires shorted N.C. operation. The yellow PRX wires will open and close with each cycle, these are used for a PLC input or for an external totalizer or counter.

Green Ground Wire: The green ground wire is used to ground the DNFT from stray voltages or currents floating around the natural gas compressor package.

OPEN LOOP MODE

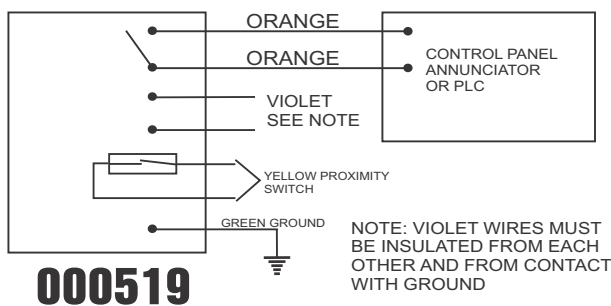

CLOSED LOOP MODE

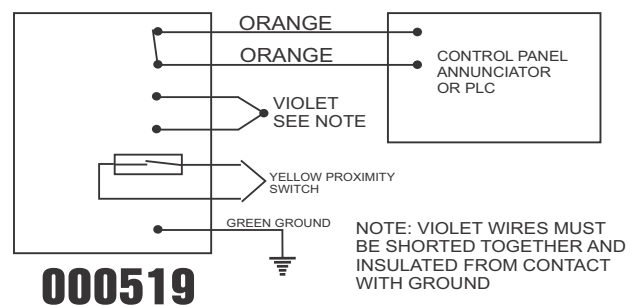

WIRING CONNECTIONS SHOWN FOR UNIT IN OPERATING MODE

PROGRAMMING PROCEDURE FOR 000519

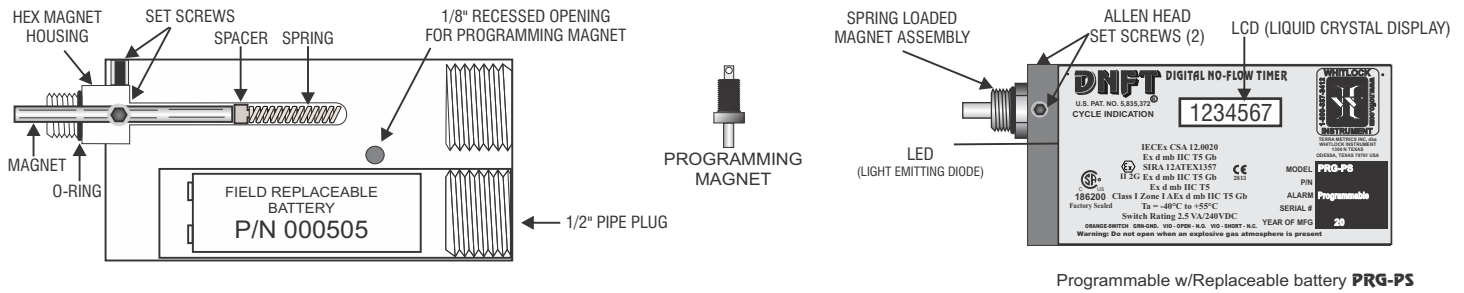

Programming Modes Available:

- MODE 1- Displays Total Divider Valve Cycles. Program Alarm Time in Seconds. MAX: 255 Sec. (4 Min. 15 Sec.) MIN: 20 Seconds
- MODE 2 - Displays Cycle Time of Divider Valve in Seconds
- MODE 3 - Displays Total Pints. Program Divider Valve Total: Maximum of 120
- MODE 4 - Displays Pump Rate in Pints Per Day

To program the DNFT, the programming magnet must be inserted into the 1/8" recessed opening located on the face of the DNFT. To change programming mode, remove and re-insert the programming magnet into the recessed opening. The current programming mode 1,2,3 or 4 will immediately be displayed followed by a "0" 2 seconds later. This "0" indicates that the current mode may be programmed.

NOTICE: DNFT MUST BE PROGRAMMED BEFORE INSTALLATION ON DIVIDER BLOCK.

Mode 1 - LCD Displays Total Divider Valve Cycles. Program Alarm Time MAX: 4 Minutes 15 Seconds (255 seconds) MIN: 20 Seconds

Insert programming magnet into the 1/8" recessed opening located on the face of the DNFT. If mode 1 is not selected in display, remove and re-insert programming magnet until the LCD indicates mode 1. Do not remove programming magnet when mode 1 is displayed. To set alarm time, depress and release spring loaded magnet assembly until desired alarm time (in seconds) is displayed on the LCD. Example: 60 counts on LCD = 60 second alarm time. Remove programming magnet. DNFT will display total divider valve cycles if left in this mode and is now set for 60.

ALARM TIME MUST BE PROGRAMMED BEFORE INSTALLING ON DIVIDER VALVE.

Mode 2 - LCD Displays Cycle Time of Divider Valve in Seconds. LCD will count each cycle of the divider valve in seconds, counting up from "0" until the divider valve completes one full cycle. When divider valve completes one full cycle, the LCD will reset to zero and begin counting each second until another cycle is completed.

Mode 3 - LCD Displays Total Pints Used. Program Divider Valve Total in This Mode. MAXIMUM DIVIDER VALVE TOTAL: 120

Insert programming magnet into 1/8" recessed opening located on the face of the DNFT. If mode 3 is not selected in display, remove and re-insert programming magnet until the LCD indicates mode 3. Do not remove programming magnet when mode 3 is displayed. To program divider valve total, add the total of the divider valve assembly on which the DNFT will be installed. Example: 24 + 24 + 24 = 72. Enter the total of the divider valve assembly by depressing and releasing the spring loaded magnet until the divider valve total is displayed on the LCD. When the total of the divider valve assembly is displayed, remove the programming magnet. The DNFT is now programmed and will record total pints on the LCD if left in mode 3. The LED blinks in all modes to indicate each divider valve cycle. This blink enables the operator to set pump rate.

Mode 4 - LCD Displays Pump Rate in Pints Per Day. FOUR (4) SECOND MINIMUM CYCLE TIME.

CAUTION: DO NOT INSERT PROGRAMMING MAGNET IN THE RECESSED OPENING WHEN THE UNIT IS MOUNTED ON DIVIDER VALVE WITH COMPRESSOR RUNNING. DNFT WILL GO INTO ALARM AND COMPRESSOR WILL SHUTDOWN. MODES CANNOT BE CHANGED WHILE DNFT IS MOUNTED ON DIVIDER VALVE WITH COMPRESSOR RUNNING.

DNFT must be removed from the divider valve to change modes. After removing DNFT from divider valve, operator may change to any mode by inserting and removing programming magnet until desired mode is displayed by LCD. Please Note: DNFT will store all programmed information until programming magnet is inserted and spring loaded magnet is depressed. If spring loaded magnet is depressed with programming magnet in place, unit defaults to zero and must be reprogrammed.

DNFT BATTERY REPLACEMENT INSTRUCTIONS

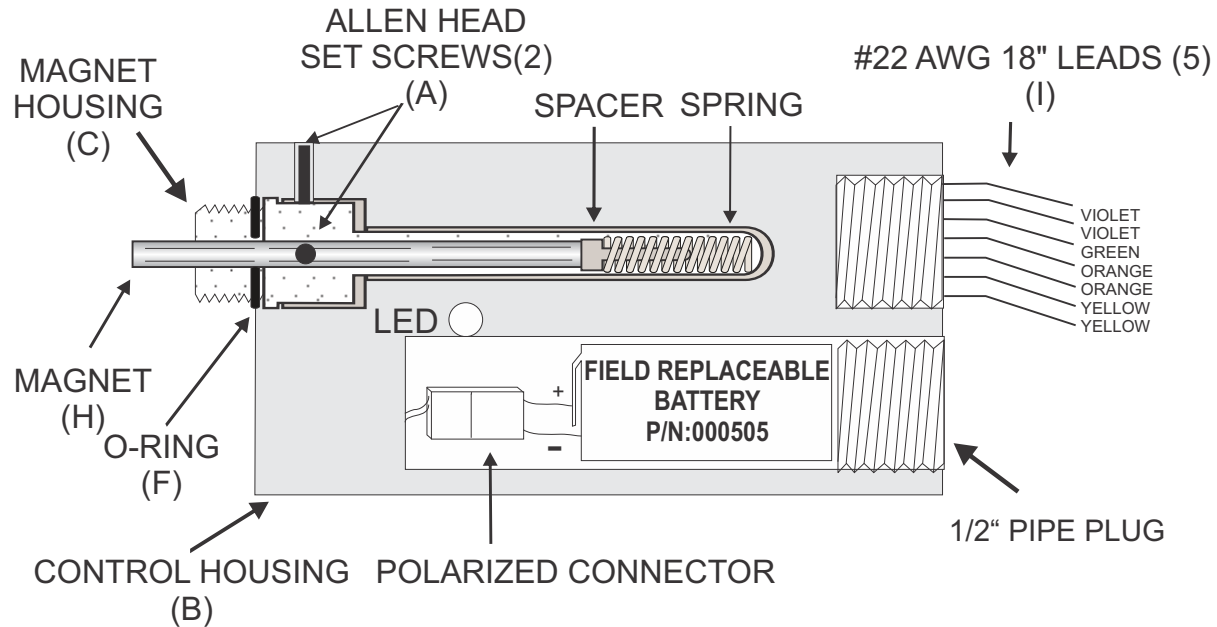

Directions for replacing the battery in the Digital No Flow Timer.

1. Shut down the engine or set the bypass timer.
2. Use a 3/8" ratchet to remove the 1/2" NPT Pipe plug.
3. Remove the battery from the DNFT and disconnect from the polarized connector.
4. Connect the new battery to the attached polarized plug.
5. Reinsert the battery and reinstall 1/2" NPT Pipe plug.
6. Verify the DNFT is working by pre-lubing the system and check for LED blink.

ITEMS REQUIRED FOR REPLACING THE DNFT BATTERY:

- (1) P/N: 000505 BATTERY
- (1) 3/8" RATCHET WRENCH (for removal of battery plug)