



CONVEYOR COMPONENTS COMPANY

MODEL CMS INSTALLATION INSTRUCTIONS

WARNING:

DEATH or SERIOUS INJURY may occur.

Before installing or adjusting, shut down and physically lock-out the conveyor system.

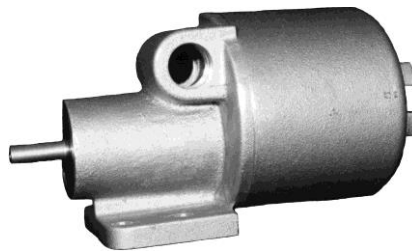

Contents

	<u>PAGE</u>
A. INTRODUCTION	
1. USAGE	2
2. HOW IT OPERATES	2
B. SPECIFICATIONS	
1. ELECTRICAL	3
2. MECHANICAL	3
C. INSTALLATION	
1. LOCATION & MOUNTING	4
2. WIRING	5
3. CONDUIT INSTALLATION	6
4. SIGNAL SET POINT	6
5. TIME DELAY SETTING	6
D. TROUBLESHOOTING	
1. PROBLEMS & SOLUTIONS	7
2. FACTORY ASSISTANCE	8
E. MOUNTING DIMENSIONS	8-9
FIGURES	
1. SUGGESTED COUPLING ARRANGEMENT	4
2. SUGGESTED COG BELT OR ROLLER CHAIN ARRANGEMENT	4
3. SUGGESTED SPUR GEAR ARRANGEMENT	5
4. CIRCUIT BOARD ARRANGEMENT	5
5. MOUNTING HOLE DIMENSIONS	8
6. MOUNTING DIMENSIONS	8
7. MOUNTING DIMENSIONS	9
8. DRILL DIMENSIONS	9

A. INTRODUCTION

1. USAGE

The model CMS motion sensing control is a compact switch designed to include all mechanical and electronic components into a single housing. It will produce an output signal at a predetermined speed which may be over-speed, under-speed or zero-speed. Rugged, heavy-duty construction combined with solid state electronics and photo-electric technology makes this one of the most advanced motion detectors available. Model CMS protects all valuable rotating equipment including belt conveyors, bucket elevators, rotary feeders or screw conveyors. It operates in a clockwise or counter-clockwise direction and mounts in any position.

2. HOW IT OPERATES

The model CMS senses motion by means of a precision metal disc mounted on the input shaft. This disc generates measurable light pulses by a series of slots on its periphery, which rotate past an infrared light source. A photo-electric sensor monitors the series of light pulses and converts them to digital electronic signals. Solid state circuitry then analyzes the digital signals and activates or de-activates the output relay at the pre-set speed.

Field adjustment of the signal set point is easily accomplished by means of an adjustment screw on the electronics. For under-speed sensing, the signal point is set below the normal operating speed of the unit. The output relay will then de-energize if the speed drops below the signal point. For over-speed sensing, the pick-up point is set above the normal operating speed. The output relay will energize if the speed exceeds the pick-up point. Zero-speed sensing can be accomplished by turning the adjustment screw to its minimum setting. The output relay will then de-energize when the shaft speed of the unit approaches zero.

B. SPECIFICATIONS

1. ELECTRICAL

Input Voltage:	105-135 volts AC, 50/60 Hz. 210-250 volts AC, 50/60 Hz. (Special Order) 24 volts AC/DC, 50/60 Hz. (Special Order)
Output:	DPDT relay to 3 Amp. Resistive at 120 volts AC DPDT relay to 3 Amp. Resistive at 240 volts AC DPDT relay to 3 Amp. Resistive at 30 volts DC 1/10 Horsepower at 120 volts AC 1/10 Horsepower at 240 volts AC
Ambient Temperature Range:	14°F to +131°F (-10°C to +55°C)
Max. Operating Temperature (CMS-X):	Class T6: 85°C (185°F)
Repeatability:	+2% maximum at constant voltage and temperature.
Power Consumption:	3 Watts
Pick-up Point:	3 speed ranges at which relay will energize: LOW: 0.1 to 10 RPM MEDIUM: 1 to 100 RPM HIGH: 10 to 1000 RPM
Signal Point:	Speed at which relay will de-energize. Recommended to be 15-20% lower than pick-up point to eliminate nuisance shutdowns.
Start-up Delay:	Adjustable up to 45 seconds.

2. MECHANICAL

Radial Load on Input Shaft:	125 lb (56.25 kg) Maximum.
End Thrust on Input Shaft:	100 lb (45 kg) Maximum.
Rotation:	Either clockwise or counter-clockwise
Driving Torque:	1"/lb (0.11 N*m) maximum.
Shaft:	5/8" (16 mm) diameter w/ 3/16" x 7/8" (5 x 22 mm) key
Enclosure:	Aluminum w/screw cover
Meets:	CMS-G:NEMA Types 3S, 4 & 4X CMS-X:NEMA Type 7: Class I groups C & D NEMA Type 9: Class II groups F & G 120 VAC units cULus Listed
Bearings:	Ball, permanently lubricated and sealed for life.
Shaft Seal:	Leather type oil seal.
Weight:	5 lb (2.25 kg)
Size:	5" high x 5" wide x 8-1/2" long (127 x 127 x 216 mm)

C. INSTALLATION

1. LOCATION & MOUNTING

The model CMS motion switch can be mounted for operation in any position. The surface to which the switch is affixed should be as flat and as smooth as possible. Bearing brackets and shim plate sets (models 311, 312, 313) can be used to mount the unit directly to the pillow block supporting a shaft. On installations where vibration conditions are not extreme, use $\frac{1}{4}$ " (6 mm) diameter machine bolts with lock washers through the four mounting holes in the base of the switch. Mounting bolts and lock washers are not furnished with the switch. If vibration conditions are extreme, use of a doweling is recommended through two mounting holes in the switch base. The switch should be mounted as axially in line, and/or parallel as possible to the existing shaft, which is to drive the switch. The model CMS motion switch can be driven by one of the following means:

FIGURE 1: Suggested Coupling Arrangement, side view. Direct connection through a coupling (preferred means). Note: Switch should be concentric with the mating shaft. If Stub is used, it must be concentric with the main shaft. If a stub shaft is required, we suggest the use of a $\frac{5}{8}$ " (16 mm) stub shaft. Use with a split or flexible type coupling.

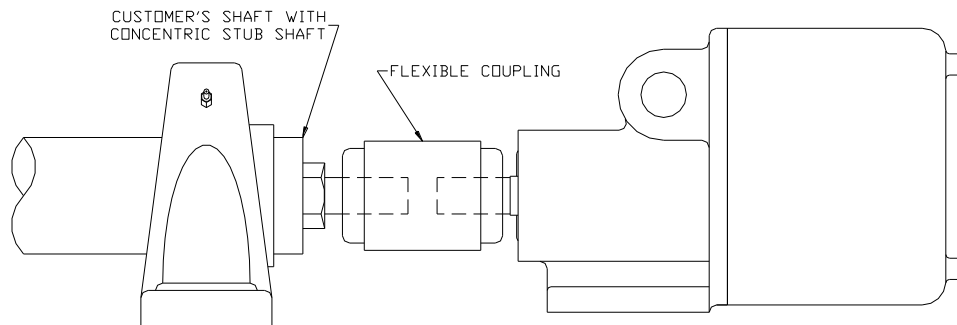

FIGURE 2: Cog Belt Drive (timing) or Roller Chain Drive: A V-Belt drive is not as desirable because of possible slippage.

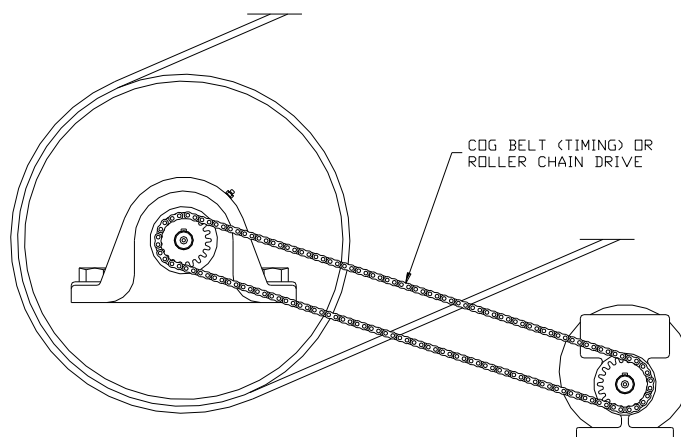
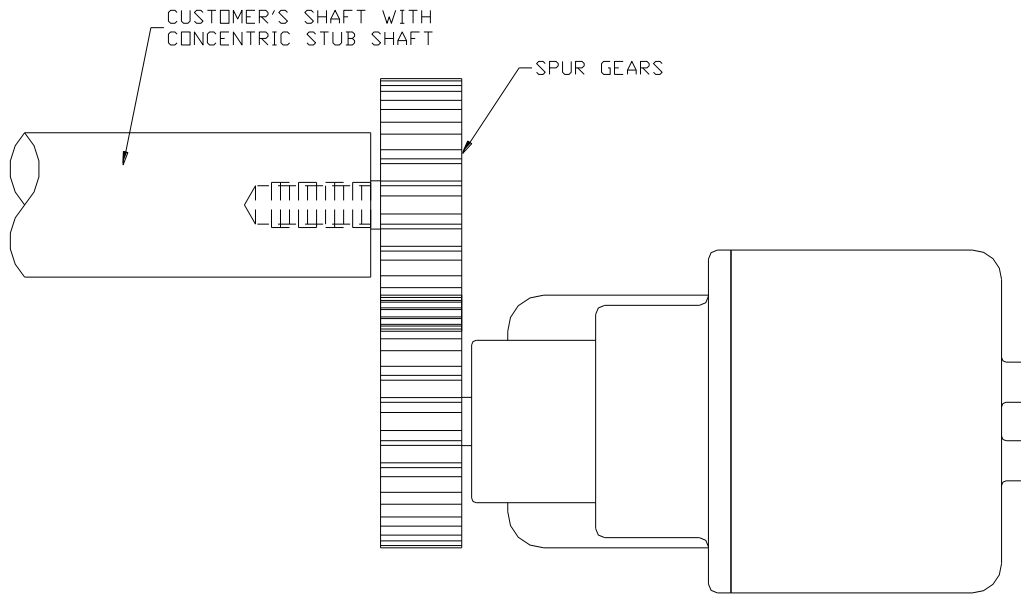

FIGURE 3: Suggested Spur Gear Arrangement (top view)



2. WIRING

Note: TWIST WIRES TOGETHER BEFORE INSERTING IN TERMINAL (ENROULEZ LES FILS ENSEMBLE AVANT LES INTRODUITE DANS LA BORNE.).

FIGURE 4: Electronics View

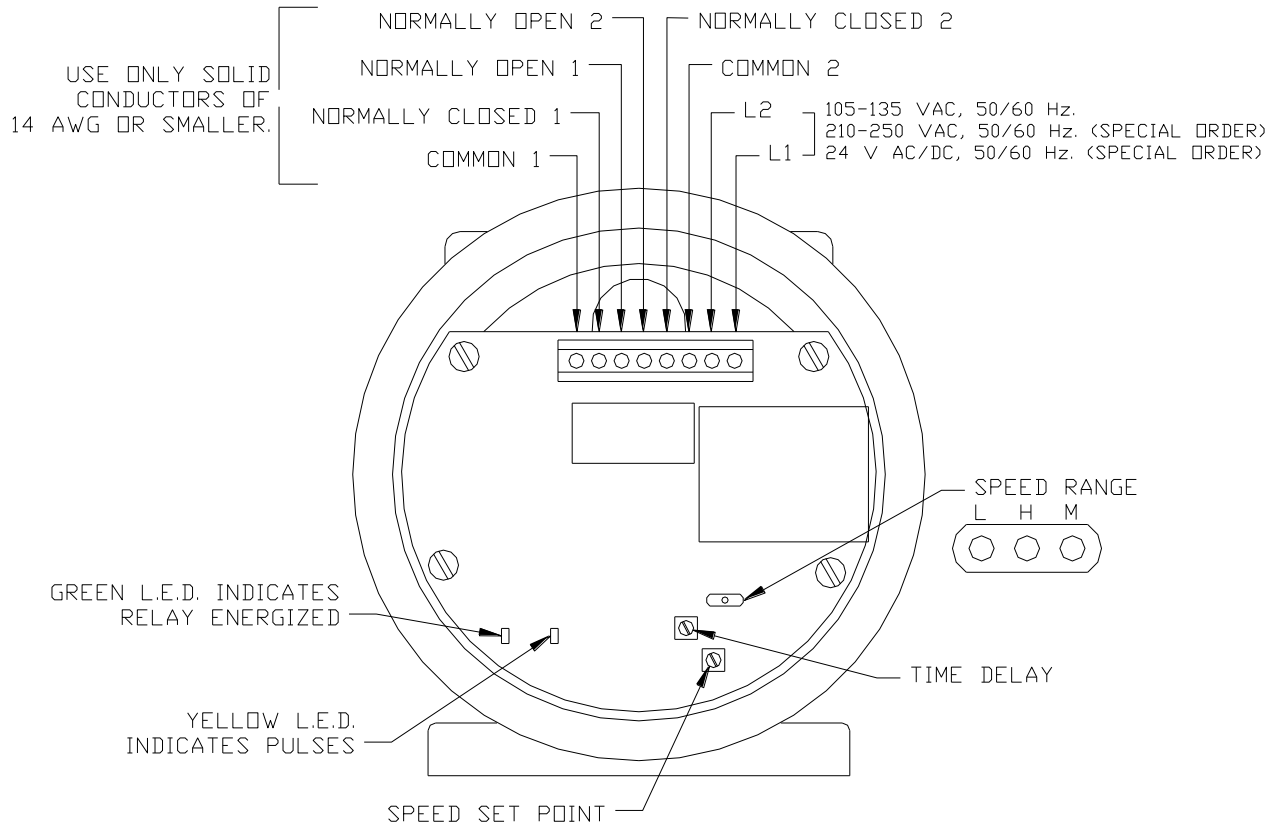

Remove end cap to expose terminals and pick-up speed adjustment screw. Wire input power from source to terminals L1 & L2. Be certain to use the provided ground screw. The output of the model CMS is a DP/DT relay. There are two sets of output contacts. Each set includes normally open, normally closed and common. As a result, the unit can be used to control two separate circuits such as a motor starter and a signal light.

3. CONDUIT INSTALLATION:

Field wiring must meet or exceed the requirements of the National Electrical Code and any other agency or authority having jurisdiction over the installation. Conduit fittings must meet applicable CSA and UL standards.

4. SIGNAL SET POINT

FOR USE AS UNDERSPEED SWITCH:

Select the speed range required by changing the switch to LOW for 0.1 to 10 RPM, MEDIUM for 1 to 100 RPM and HIGH for 10 to 1000 RPM. Turn the set point potentiometer to the counter-clockwise stop. With motion present on the input shaft and at normal operating RPM, the yellow L.E.D. should blink. The green L.E.D. should turn on indicating that the output relay is energizing. Slowly turn the set point adjustment screw clockwise until the output relay de-energizes and the green L.E.D. turns off. (A "click" will occur at this point.) Back up until the output relay energizes. Thus, when speed drops below the set point, the green L.E.D. should turn off indicating that the output relay is de-energized. NOTE: Typically, the motor contact is wired in series with one of the N.O. output contacts and an alarm is wired with one of the N.C. output contacts.

FOR USE AS OVERSPEED SWITCH:

Select the speed range required by changing the switch to LOW for 0.1 to 10 RPM, MEDIUM for 1 to 100 RPM and HIGH for 10 to 1000 RPM. Turn the set point potentiometer to the counter-clockwise stop. With motion present on the input shaft and at normal operating RPM, the yellow L.E.D. should blink. The green L.E.D. should turn on indicating that the output relay is energized. Slowly turn the set point adjustment screw clockwise until the output relay de-energizes and the green L.E.D. turns off. (A "click" will occur at this point.) With the potentiometer on that setting, if the speed increases the output relay will energize. NOTE: Typically, the motor contact is wired in series with one of the N.O. output contacts and an alarm is wired with one of the N.C. output contacts.

FOR USE AS A ZERO SPEED SWITCH:

Use the HIGHEST speed range possible for the application. Turn the set point potentiometer slightly under the current running speed, as indicated by the green LED turning on, and then adjust the potentiometer slightly under this setting. If the speed drops below this set point, the output relay will de-energize. Typically, the motor contact is wired in series with one of the N.O. output contacts, and an alarm is wired with one of the N.C. output contacts. NOTE: very slow speeds will cause a mechanical delay in the sensor operation, resulting in a longer time lapse before response.

5. TIME DELAY SETTING

The model CMS motion sensing control has a start-up delay that is adjustable up to 45 seconds. This setting should be set, depending on the application and the length of time it takes for the conveyor to reach its normal operating RPM. This time delay takes effect upon power-up of the model CMS after shutdown. This delay only effects start-up, avoiding nuisance start-up alarms.

NOTE: The input power supplied to the model CMS must be interrupted for start-up delay timer to be reset.

D. TROUBLESHOOTING

1. PROBLEMS & SOLUTIONS

PROBLEM:	SOLUTION:
Unit not functioning; no pulses from yellow LED.	<p>Check power supply and voltage.</p> <p>Make sure input shaft is turning: yellow LED flashing.</p> <p>Clean or polish disk to increase reflectivity.</p> <p>Replace disk if bent or distorted.</p> <p>Circuit board may be too close to disk: shim electronics board with 1 small washer on each standoff.</p> <p>If shaft has been forced into housing, disk will be too close to sensor: contact factory for repair estimate.</p>
Input shaft does not spin freely; shaft may be damaged.	Return to factory for repair.
Alarm sounds when equipment is started.	<p>Start-up delay setting may be too short: increase if needed.</p> <p>Check for proper connections between alarm and relay.</p> <p>AC power to CMS must be interrupted for alarm to reset.</p>
Alarm does not sound when expected.	<p>Check power supply.</p> <p>Check for proper connections between alarm and relay.</p>
Equipment is not shut off when expected.	<p>Check power supply.</p> <p>Check for proper connections between control circuit and relay.</p>
Yellow LED is on steady with rotation.	Electronics exposed to outdoor infrared (sun) light: install cover or shield unit during calibration.
Green LED changes state yet relay contacts do not transfer.	Relay contacts damaged or closed: replace electronics board.
Relay takes a long time to change state at very low speeds, especially when used as a zero speed switch.	<p>NOTE: Very slow speed mechanically delays sensor operation, resulting in a longer response to changes.</p> <p>Use a higher speed range if possible.</p> <p>Increase shaft speed with belt or chain drive.</p> <p>Use a multiplier sprocket to increase RPM.</p> <p>Use highest range that includes alarm speed needed.</p> <p>Adjust time delay potentiometer slightly clockwise. Do not set the time delay pot completely CCW.</p> <p>Consult factory.</p>
Relay contacts do not switch as expected.	Relay contacts are labeled in alarm (no motion) state.
Vibration is causing false trips.	Mount unit separately from vibrating machinery and drive with belt or chain.

2. FACTORY ASSISTANCE

If assistance is needed to locate difficulties with a unit or you would like information about alternate control devices, please call the factory at 1-800-233-3233.

To help solve a problem quickly, please have as much of the following information as possible when you make your call:

Model Number	Date Purchased
Brief Application Information	Brief Description of the Problem

EQUIPMENT SHIPPED BACK TO THE FACTORY WITHOUT PROPER AUTHORIZATION WILL BE REFUSED AND RETURNED AT THE SHIPPER'S EXPENSE.

E. MOUNTING DIMENSIONS

FIGURE 5

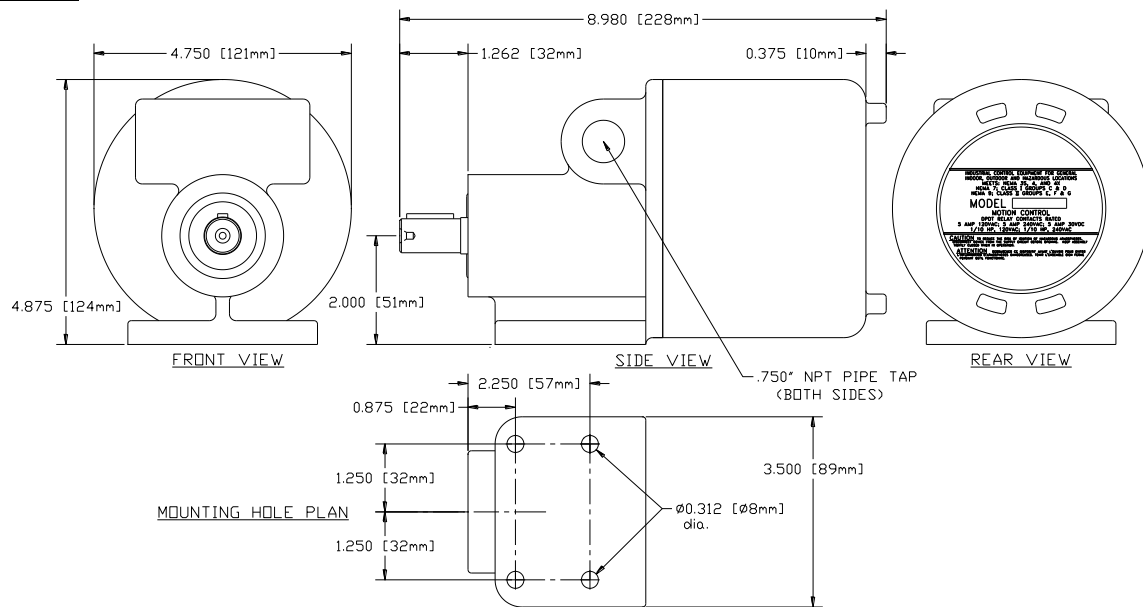

FIGURE 6

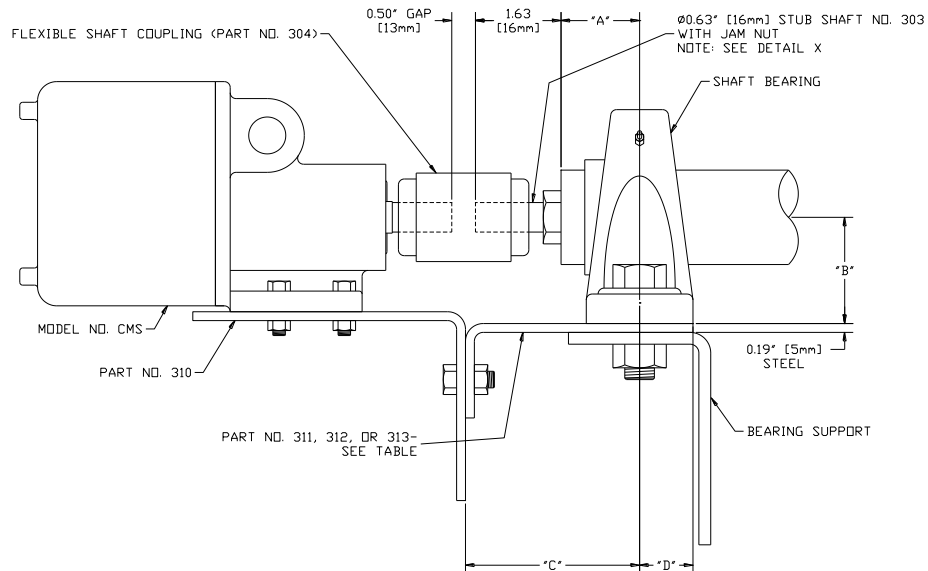
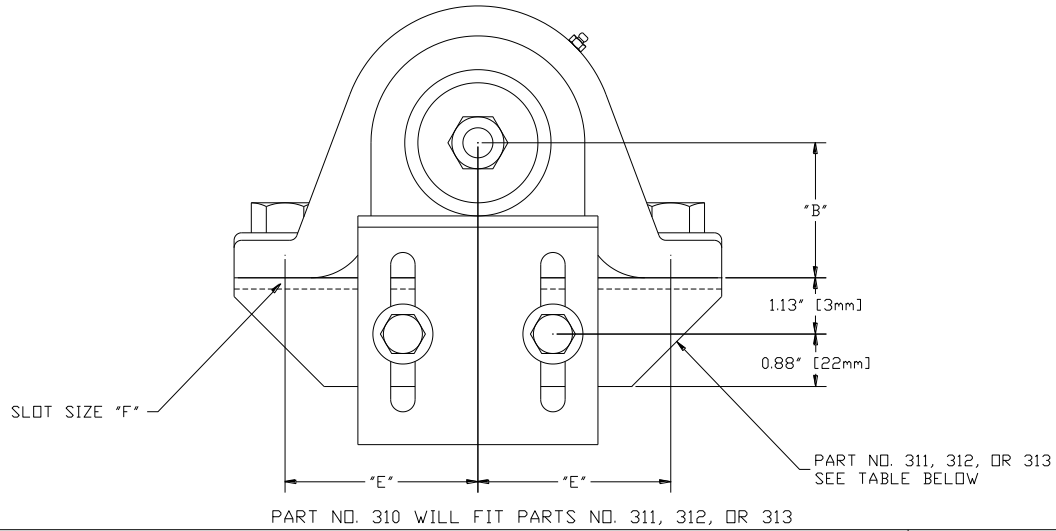

FIGURE 7



ALL DIMS IN INCHES, EXCEPT DIMS IN [] ARE IN MILLIMETERS.							BEARING BRACKET & SHIM PLATE PART NO.
SHAFT DIA.	"A"	"B"	"C"	"D"	"E"	"F"	
1.44 [11]	1.25 TO 2.00 [32 TO 51]	1.88 TO 2.13 [48 TO 54]	3.13 [79]	1.13 [29]	5.38 [137]	0.56 W x 1.31 LG [14 W x 33 LG]	311
1.94 TO 2.44 [49 TO 62]	1.50 TO 2.56 [38 TO 65]	2.25 TO 3.00 [57 TO 76]	3.75 [95]	1.63 [41]	7.38 [187]	0.81 W x 1.94 LG [21 W x 49 LG]	312
2.94 TO 3.94 [75 TO 100]	3.00 TO 3.75 [76 TO 95]	3.13 TO 4.13 [79 TO 105]	4.50 [114]	2.19 [56]	9.63 [244]	1.06 W x 2.56 LG [27 W x 65 LG]	313

FIGURE 8

DRILL $\phi 17/32$ " [13mm] X 1.75" [44mm] DEEP (MIN.)
TAP 5/8"-11 N.C. R.H. THREAD X 1.38" [35mm] DEEP

PREFERRED ROTATION
SEE NOTE

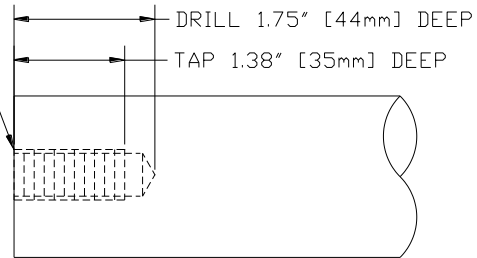
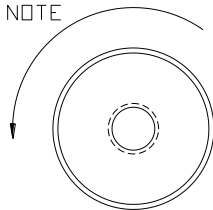

DETAIL X

NOTE: WHEN THREADED STUB SHAFT (PART NO. 303) IS USED, IT IS RECOMMENDED THAT THE LOCATION OF THE STUB BE IN THE END OF THE SHAFT THAT ROTATES COUNTER-CLOCKWISE. THIS ALLOWS THE THREADS TO CONTINUE BEING UNDER A CONSTANT FASTENING TORQUE WHILE THE SHAFT TURNS. IF THE ROTATION IS CLOCKWISE OR THE SHAFT IS FOR REVERSING TYPE SERVICE, MAKE SURE THE JAM NUT IS LOCKED TIGHT AGAINST THE SHAFT.