



SERIES V6 | W.E. ANDERSON FLOTECT® MINI-SIZE FLOW SWITCHES



V6 with tee



V6 low flow

FEATURES/BENEFITS

- Unique magnetically actuated switching design gives superior performance
- Features a free-swinging vane which attracts a magnet within the solid metal switch body, actuating a snap switch by means of a simple lever arm with no bellows, springs, or seals to fail
- Leak proof body machined from bar stock
- Electrical assembly can be easily replaced without removing the unit from installation so that the process does not have to be shut down
- Choice of models in a tee with calibrated vane or field adjustable trimmable vane
- Easy installation with simple pipe insert via tee and simple electrical switch connections
- High-pressure rating of 1000 psig (69 bar) with brass body and 2000 psig (138 bar) with stainless steel body
- Low flow model offers field adjustable set point

APPLICATIONS

- Protects pumps, motors and other equipment against low or no flow
- Controls sequential operation of pumps
- Automatically starts auxiliary pumps and engines
- Stops liquid cooled engines, machines and processing when coolant flow is interrupted
- Shuts down burner when air flow through heating coil fails
- Controls dampers according to flow
- Signals alarm when emergency shower or eyewash station in use

DESCRIPTION

The **Series V6 Flotect® Mini-Size Flow Switches** are surprisingly compact, and specifically engineered to monitor liquid, gas, or air flows. Time tested in thousands of pipeline installations and processing plants around the world, this Series is Weatherproof, designed to meet NEMA 4 and Explosion-proof (listing included in specifications). Tees are available for installation in pipelines from 1/2" to 2". With bushings added the unit is easily adapted to 1/4" and 3/8" piping.

SPECIFICATIONS

Service	Gases or liquids compatible with wetted materials.
Wetted Materials	Standard V6 models: Vane: 301 SS; Lower body: Brass or 303 SS; Magnet: Ceramic; Other: 301, 302 SS; Tee: Brass, iron, forged steel, or 304 SS. V6 low flow models: Lower body: Brass or 303 SS; Tee: Brass or 304 SS; Magnet: Ceramic; O-ring: Buna-N standard, fluoroelastomer optional; Other: 301, 302 SS.
Temperature Limits	-4 to 220°F (-20 to 105°C) standard, MT high temperature option 400°F (205°C) (MT not UL, CSA, ATEX, IECEx or KC) ATEX compliant AT, IECEx IEC option and KC (KC option); Ambient temperature: -4 to 167°F (-20 to 75°C); Process temperature: -4 to 220°F (-20 to 105°C).
Pressure Limit	Brass lower body with no tee models 1000 psig (69 bar), 303 SS lower body with no tee models 2000 psig (138 bar). Brass tee models 250 psi (17.2 bar), iron tee models 1000 psi (69 bar), forged and SS tee models 2000 psi (138 bar), low flow models 1450 psi (100 bar).
Enclosure Rating	Weatherproof and explosion-proof. Listed with UL and CSA for Class I, Groups A, B, C and D; Class II, Groups E, F, and G. (Group A on stainless steel body models only). ATEX CE 2813 Ex II 2 G Ex db IIC T6 Gb Process Temp ≤75°C Alternate Temperature Class T5 Process Temp ≤90°C, 115°C (T4) Process Temp ≤105°C consult factory. EU-Type Certificate No.: KEMA 04ATEX2128. ATEX Standards: EN 60079-0:2012+A11:2013; EN 60079-1:2014. IECEx Certified: For Ex db IIC T6 Gb Process Temp ≤75°C Alternate Temperature Class T5 Process Temp ≤90°C, 115°C (T4) Process Temp ≤105°C consult factory. IECEx Certificate of Conformity: IECEx DEK 11.0039; IECEx Standards: IEC 60079-0:2011; IEC 60079-1:2014; Korean Certified (KC) for: Ex d IIC T6 Gb Process Temp ≤75°C; KTL Certificate Number: 12-KB4BO-0091.
Switch Type	SPDT snap switch standard, DPDT snap switch optional.
Electrical Rating	UL models: 5 A @125/250 VAC. CSA, ATEX and IECEx models: 5 A @ 125/250 VAC (V~); 5 A res., 3 A ind. @ 30 VDC (V--). MV option: .1 A @ 125 VAC (V~). MT option: 5 A @125/250 VAC (V~). [MT option not UL, CSA, ATEX or IECEx].
Electrical Connections	UL models: 18 AWG, 18" (460 mm) long. ATEX/CSA/IECEx models: Terminal block.
Upper Body	Brass or 303 SS.
Conduit Connection	3/4" male NPT standard, 3/4" female NPT or M25 with BSPT option on junction box models.
Process Connection	1/2" male NPT or 1/2" male BSPT on models without a tee.
Mounting Orientation	Switch can be installed in any position but the actuation/deactuation flow rates in the charts are based on horizontal pipe runs and are nominal values.
Set Point Adjustment	Standard V6 models none. Without tee models vane is trimmable. Low flow models are field adjustable in the range shown. See set point charts.
Weight	2 to 6 lb (.9 to 2.7 kg) depending on construction.
Options not Shown	Custom calibration, bushings, PVC tee, reinforced vane, DPDT relays.
Agency Approvals	ATEX, CE, CSA, IECEx, KTL, UL.

DIMENSIONS

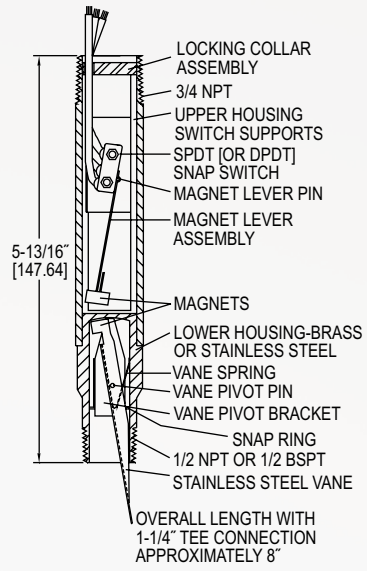

V6 with tee

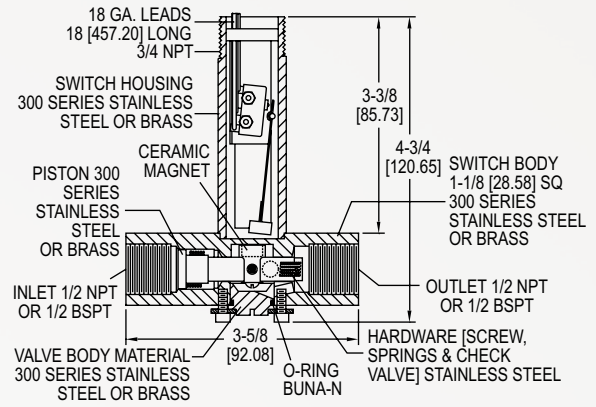

V6 low flow

HOW TO ORDER

Use the **bold** characters from the chart below to construct a product code.

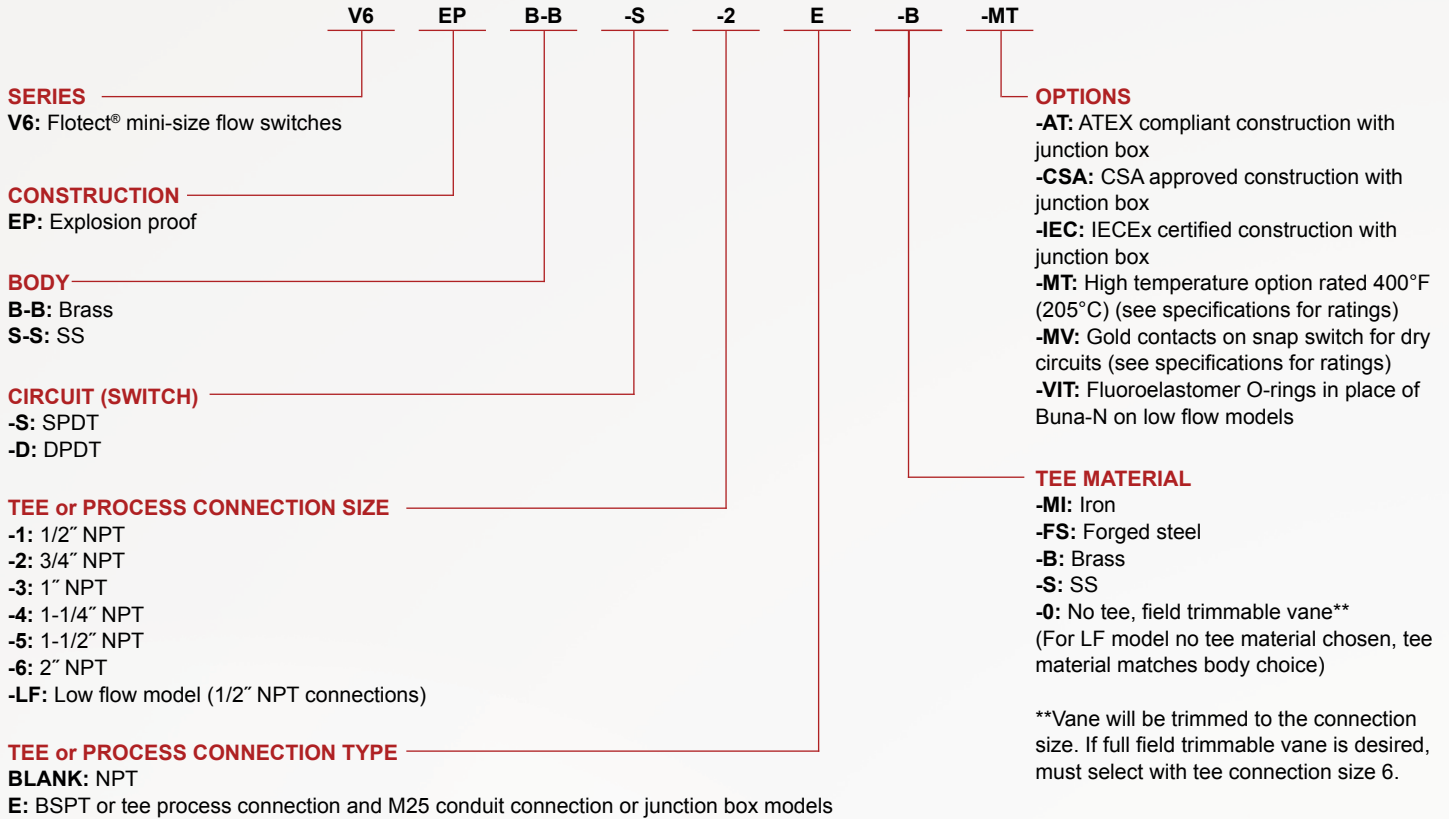

SET POINT CHARTS

APPROXIMATE ACTUATION/DEACTUATION FLOW RATES FOR AIR; SCFM (LPM)		
Pipe Size	Actuate	Deactuate
1/2"	6.50 (180)	5.00 (120)
3/4"	10.0 (300)	8.00 (240)
1"	14.0 (420)	12.0 (360)
1-1/4"	21.0 (600)	18.0 (540)
1-1/2"	33.0 (960)	30.0 (840)
2"	43.0 (1200)	36.0 (1020)

APPROXIMATE ACTUATION/DEACTUATION FLOW RATES FOR COLD WATER; GPM (LPM)		
Pipe Size	Actuate	Deactuate
1/2"	1.50 (5.667)	1.00 (3.83)
3/4"	2.00 (7.5)	1.25 (4.67)
1"	3.00 (11.33)	1.75 (6.67)
1-1/4"	4.00 (15.17)	3.00 (11.3)
1-1/2"	6.00 (22.67)	5.00 (18.9)
2"	10.00 (37.83)	8.50 (32.2)

V6 set point charts - Factory installed tee

MIN-MAX FLOW RATES IN 1/2" PIPE		
Media	Actuate	Deactuate
GPM-water	.04-0.75	.03-0.60
LPM-water	.15-2.84	.11-2.27
SCFM-air	.18-2.70	.15-2.0
LPS-air	.09-1.3	.07-.95

Pressure drop (head loss) is a function of both set point and flow rate. Typically, pressure drop at actuation flow rate listed will be 5-10 psid (.34-.69 bar). Pressure drops at other flow rates will vary in proportion to the (change in flow).

V6 low flow set point chart