

W6D910-GA01-01

AC axial fan - HyBlade®

sickled blades (S series)

with full square nozzle



Nominal data

| | | | |
|-------------------------------|-------------------|------|------|
| Type | W6D910-GA01-01 | | |
| Motor | M6D138-NA | | |
| Phase | | 3~ | 3~ |
| Nominal voltage | VAC | 400 | 400 |
| Connection | | Δ | Y |
| Frequency | Hz | 50 | 50 |
| Type of data definition | | ml | ml |
| Valid for approval / standard | | CE | CE |
| Speed | min ⁻¹ | 885 | 685 |
| Power input | W | 2480 | 1570 |
| Current draw | A | 5.15 | 2.9 |
| Max. back pressure | Pa | 150 | 90 |
| Min. ambient temperature | °C | -40 | -40 |
| Max. ambient temperature | °C | 50 | 50 |
| Starting current | A | 18.6 | 6.2 |

ml = Max. load · me = Max. efficiency · fa = Running at free air · cs = Customer specs · cu = Customer unit
Subject to alterations

Data according to ErP directive

| | |
|-----------------------|--------|
| Installation category | A |
| Efficiency category | Static |
| Variable speed drive | No |
| Specific ratio* | 1.00 |

* Specific ratio = $1 + p_{fs} / 100\,000\text{ Pa}$

| | | Actual | Request 2013 | Request 2015 |
|--------------------------------|-------------------|--------|--------------|--------------|
| Overall efficiency η_{es} | % | 36.1 | 32.1 | 36.1 |
| Efficiency grade N | | 40 | 36 | 40 |
| Power input P_e | kW | 2.46 | | |
| Air flow q_v | m ³ /h | 21770 | | |
| Pressure increase p_{fs} | Pa | 142 | | |
| Speed n | min ⁻¹ | 890 | | |

Data definition with optimum efficiency. LU-136151
The ErP data is determined using a motor-impeller combination in a standardised measurement configuration.

W6D910-GA01-01

AC axial fan - HyBlade®

sickled blades (S series)

with full square nozzle

Technical features

| | |
|---|--|
| Mass | 52.4 kg |
| Size | 910 mm |
| Surface of rotor | Cast in aluminium |
| Material of terminal box | PP plastic |
| Material of blades | Aluminium sheet insert, sprayed with PP plastic |
| Material of wall ring | Sheet steel, pre-galvanised and coated in black plastic (RAL 9005) |
| Material of guard grille | Steel, coated in black plastic (RAL9005) |
| Number of blades | 5 |
| Blade angle | 0° |
| Direction of air flow | "V" |
| Direction of rotation | Clockwise, seen on rotor |
| Type of protection | IP 54 |
| Insulation class | "F" |
| Humidity class | F3-1 |
| Max. permissible ambient motor temp. (transp./ storage) | + 80 °C |
| Min. permissible ambient motor temp. (transp./storage) | - 40 °C |
| Mounting position | Any |
| Condensate discharge holes | On rotor and stator sides |
| Operation mode | S1 |
| Motor bearing | Ball bearing |
| Touch current acc. IEC 60990 (measuring network Fig. 4, TN system) | <= 3.5 mA |
| Electrical leads | Via terminal box |
| Motor protection | Thermal overload protector (TOP) brought out |
| Cable exit | Axial |
| Protection class | I (if protective earth is connected by customer) |
| Product conforming to standard | EN 60034; EN 61800-5-1; CE |
| Approval | EAC; VDE |

W6D910-GA01-01

AC axial fan - HyBlade®

sickled blades (S series)

with full square nozzle

Product drawing

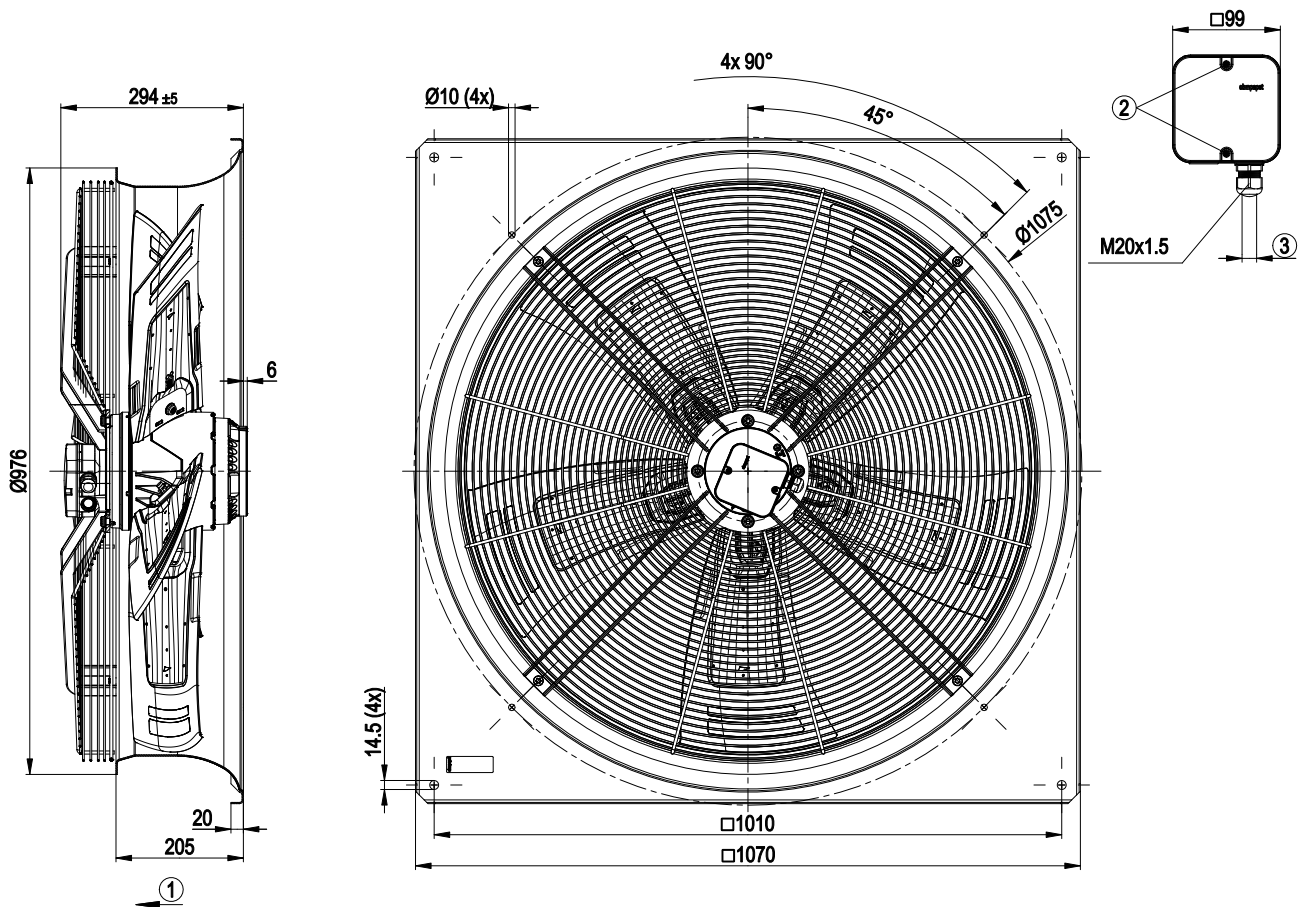

| | |
|---|--|
| 1 | Direction of air flow "V" |
| 2 | Tightening torque 1.5 ± 0.2 Nm |
| 3 | Cable diameter: min. 7 mm, max. 14 mm; tightening torque: 2 ± 0.3 Nm |

AC axial fan - HyBlade®

sickled blades (S series)

with full square nozzle

Connection screen

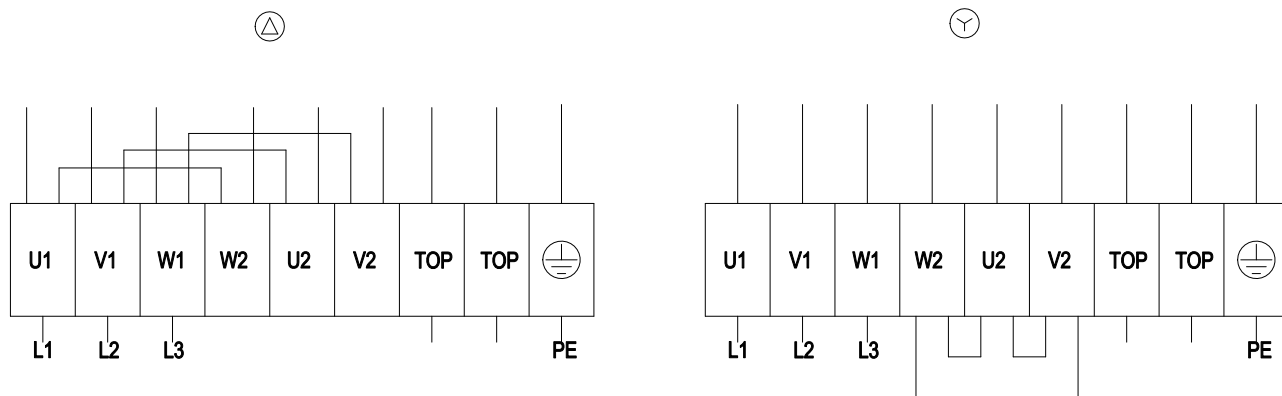

| | | | | | |
|----|------------------|----|-----------------|-----|--------------|
| Δ | Delta connection | Y | Star connection | L1 | = U1 = black |
| L2 | = V1 = blue | L3 | = W1 = brown | W2 | yellow |
| U2 | green | V2 | white | TOP | 2 x grey |
| PE | green/yellow | | | | |

Charts: Air flow 50 Hz

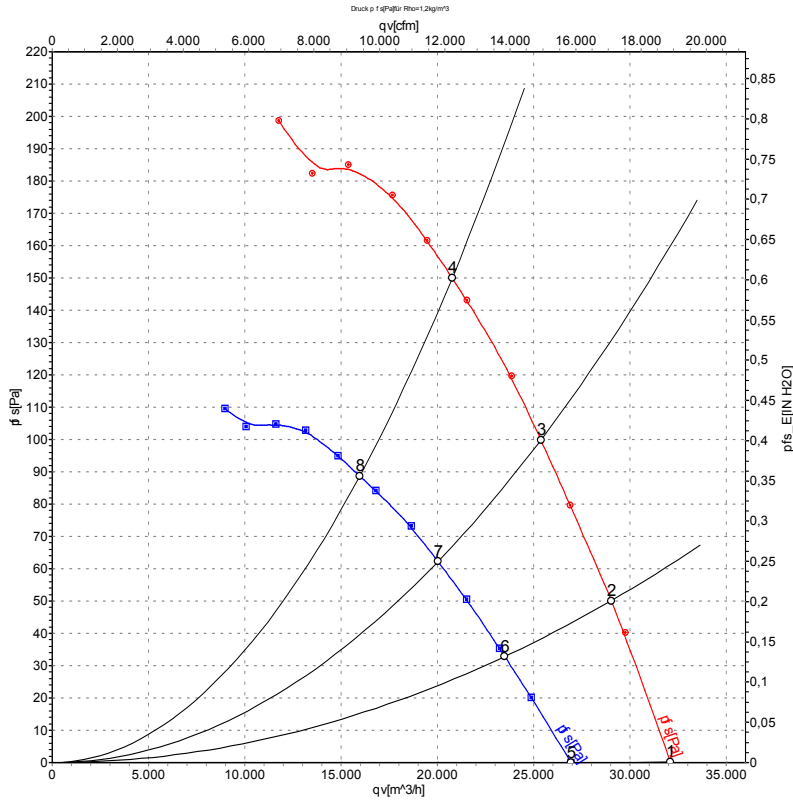

Measurement: LU-117504
Measurement: LU-118398

Air performance measured as per ISO 5801 Installation category A. For detailed information on the measuring set-up, please contact ebm-papst. Suction-side noise levels: LwA measured as per ISO 13347 / LpA measured with 1m distance to fan axis. The values given are valid under the measuring conditions mentioned above and may vary according to the actual installation situation. With any deviation from the standard set-up, the specific values have to be checked and reviewed with the unit installed.

Measured values

| | Conn. | U | f | n | P _e | I | LpA _{in} | LwA _{in} | LwA _{out} | qv | p _{fs} |
|---|-------|-----|----|-------------------|----------------|------|-------------------|-------------------|--------------------|-------------------|-----------------|
| | | V | Hz | min ⁻¹ | W | A | dB(A) | dB(A) | dB(A) | m ³ /h | Pa |
| 1 | Δ | 400 | 50 | 930 | 1786 | 4.38 | 70 | 77 | 78 | 32100 | 0 |
| 2 | Δ | 400 | 50 | 915 | 2050 | 4.67 | 68 | 75 | 75 | 29020 | 50 |
| 3 | Δ | 400 | 50 | 900 | 2262 | 4.88 | 68 | 75 | 75 | 25370 | 100 |
| 4 | Δ | 400 | 50 | 885 | 2480 | 5.15 | 70 | 77 | 77 | 20770 | 150 |
| 5 | Y | 400 | 50 | 785 | 1291 | 2.44 | 65 | 73 | 73 | 26940 | 0 |
| 6 | Y | 400 | 50 | 750 | 1410 | 2.67 | 63 | 70 | 70 | 23500 | 33 |
| 7 | Y | 400 | 50 | 715 | 1489 | 2.82 | 61 | 69 | 69 | 20030 | 62 |
| 8 | Y | 400 | 50 | 685 | 1570 | 2.90 | 63 | 71 | 70 | 15980 | 90 |

Conn. = Connection · U = Supply voltage · f = Frequency · n = Speed · P_e = Power input · I = Current draw · LpA_{in} = Sound pressure level inlet side · LwA_{in} = Sound power level inlet side
LwA_{out} = Sound power level outlet side · qv = Air flow · p_{fs} = Pressure increase