

ELECTRONIC ACTUATOR

MINI-TOP ELECTRONIC ACTUATOR

(linear type)

Functions & Features

- Small-size control valve actuator
- 1/1000 high resolution
- Seal-spring incorporated for both directions; usable with three-way valves
- Easy adjustment: electronic limiter at the valve open & closed positions
- Overload protection
- Various power inputs

Typical Applications

- Actuator for automatic control valve in pilot plants
- Air-conditioning in buildings or plants
- Micro-flow control for pharmaceutical injection
- For small-size control valves

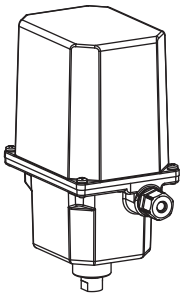

MODEL: MSP6-[1][2][3][4]-[5][6][7][8]

ORDERING INFORMATION

- Code number: MSP6-[1][2][3][4]-[5][6][7][8]

Specify a code from below for each of [1] through [8].

(e.g. MSP6-361T-ACR/F/P/Q)

- Special input range (for codes Z and 0)
- Specify the specification for option code /Q (e.g. /SET)

[1] STROKE

3: 10 to 20 mm (.39" to .79")

4: 20 to 40 mm (.79" to 1.57") (Not available for /P)

Y: 10 to 22 mm (.39" to .87") (Not available for /P)

For Japan sales only.

Select 'Y' when the yoke set (model: YSS-1) is used.

Must select '8: M8 female thread, 1.0 pitch' as [3] OUTPUT STEM TYPE.

[2] OPERATION TIME, THRUST

3: 5 sec. / 10 mm, 600 N

4: 8 sec. / 10 mm, 1200 N

6: 15 sec. / 10 mm, 2500 N

[3] OUTPUT STEM TYPE

6: M6 female thread, 0.75 pitch

8: M8 female thread, 1.0 pitch

1: M10 female thread, 1.25 pitch

D: M6 female thread, 1.0 pitch

E: M8 female thread, 1.25 pitch

F: M10 female thread, 1.5 pitch

[4] TERMINAL BOX

T: With

0: Without

[5] INPUT

Current

A: 4 - 20 mA DC (Input resistance 250 Ω)

Z: Specify current (See INPUT SPECIFICATIONS)

Voltage

6: 1 - 5 V DC (Input resistance approx. 1 MΩ)

0: Specify voltage (See INPUT SPECIFICATIONS)

[6] CE & UKCA MARKING

C: With CE and UKCA

0: Without

[7] POWER SUPPLY VOLTAGE

AC Power

A: 24 V AC (Operational voltage range 24 V ±10 %, 47 - 66 Hz)
(Not selectable for CE or UKCA)

K3: 100 - 120 V AC

(Operational voltage range 90 - 132 V, 47 - 66 Hz)
(Not selectable for CE and UKCA)

L3: 200 - 240 V AC

(Operational voltage range 180 - 264 V, 47 - 66 Hz)
(Not selectable for CE and UKCA)

DC Power

R: 24 V DC

(Operational voltage range 24 V ±10 %, ripple 10 %p-p max.)

[8] OPTIONS (multiple selections)

Control Signals

blank: Without

/L: Full-open/-closed signal

/F: Forced open/close signal

/B: Full-open/-closed and forced open/close signals

(Select 'With Terminal Box.')

Long-life Potentiometer

blank: Standard potentiometer

/P: Long-life potentiometer (for 20 mm stroke only)

(Not available when /L or /B is selected)

Other Options

blank: none

/Q: Option other than the above (specify the specification)

SPECIFICATIONS OF OPTION: Q

EX-FACTORY SETTING

/SET: Preset according to the Ordering Information Sheet
(No. ESU-4854)

GENERAL SPECIFICATIONS

Degree of protection: IP66

Action: Direct or Reverse; field selectable with DIP switches

Ex-factory setting: Reverse

In "Reverse" action, the output stem moves upward as the input signal increases when the actuator is mounted upright.

Operation at abnormally low input:

- Retract/move upward
- Extend/move downward
- Stop

Ex-factory setting: Extend/move downward

(The operation direction of the output stem when the actuator is mounted upright)

Field selectable with DIP switches

Abnormal signal level: $-16 \pm 2.5\%$

Electrical connection

•Without terminal box

Wiring conduit: Cable connector with 1 m wire (0.5 mm²)

•With terminal box

(Sequential control signal suffix code: B)

Wiring conduit: G 1/2 female (two)

Terminal screws: M3 pillar terminal

•With terminal box

(Sequential control signal suffix code: other than B)

Wiring conduit: G 1/2 female (two)

Terminal screws: M3 chromated steel
(torque 0.5 N·m)

Housing material: Diecast aluminum (ADC.12)

Drive: Stepping motor

Insulation class: E

Position detection: Potentiometer

- Common specification (contact conductive)

Deadband: 0.1 - 4.5 % adjustable

Ex-factory setting: 1.5 %

Restarting timer: 0 - 10 sec.

Ex-factory setting: 1.5 sec.

Isolation: AC power to signal

Zero adjustment: 0 - 25 %

Span adjustment: 50 - 100 %

Protective functions: Overload (lock) protection

Power indicator: Green LED is ON while power is supplied

Input indicator: Green LED is ON while normal signal is input

Status indicator LED: Red LED blinks at intervals of: 2 sec. in normal operation; and 0.5 sec. when an overload (lock) is detected

Manual operating handle: Not available

Output stem operation distance and adjustable range

3: 10 - 20 mm

- Ex-factory setting: 0 - 20 mm

- Adjustable range: 0 - 10 mm (min. distance)

4: 20 - 40 mm (Not available for /P)

- Ex-factory setting: 0 - 40 mm

- Adjustable range: 0 - 20mm (min. distance)

Y: 10 - 22 mm (Not available for /P)

- Ex-factory setting: 0 - 20 mm

- Adjustable range: 0 - 22 mm (max. distance)

- Adjustable range: 0 - 10 mm (min. distance)

INPUT SPECIFICATIONS

■ **DC Current:** Input resistor incorporated (250 Ω)

■ **DC Voltage:** 1 - 5 V DC or specific range within 0 - 5 V DC, minimum span 1 V

(For a current input, convert the current to a voltage with 250 Ω)

Input resistance: Approx. 1 MΩ

■ **Forced open/close signal:** Dry contact inputs to command to go up and go down

Rating: 5 V DC @ 2.5 mA

(go up and go down when upright mount)

OUTPUT SPECIFICATIONS

■ **Operation Time & Torque** (at rated power voltage)

MSP6-x3: 5 sec. /10 mm 600 N (135 lbf)

MSP6-x4: 8 sec. /10 mm 1200 N (270 lbf)

MSP6-x6: 15 sec. /10 mm 2500 N (562 lbf)

■ **DC Voltage:** 1 - 5 V DC (not isolated)

With "direct" action, 5 - 1 V DC position output is provided proportionally to 4 - 20 mA DC (1 - 5 V DC) input.

Load resistance: $\geq 5\text{ k}\Omega$

■ **Full-open / -closed signals:** Limit switch contact

Rating: 125 V AC @ 0.75 A ($\cos \phi = 1$)

30 V DC @ 0.6 A (resistive load)

Mechanical life: 3×10^7 cycles

Maximum operation frequency: 60 cycles/min.

INSTALLATION

Power consumption

- AC: 25 VA
- DC: 0.6 A

(Current is approx. 1.5 times as high as the above figure during the motor startup)

Operating temperature: -5 to +55°C (23 to 131°F)

Operating humidity: 30 to 85 %RH (non-condensing)

Vibration

•Sweep endurance test

Acceleration: 2 G (19.6 m/s²)

Frequency: 10 to 1000 Hz

Cycle: 20 cycles

Rate: 1 Oct./min.

Endurance: approx. 4 hr. 30 min.

Direction: X, Y, Z

Mounting position: All directions

However, DO NOT mount the actuator with its output stem or cable connector facing upward if the actuator is to be exposed to dripping water.

Weight

DC powered: 3.5 kg (7.7 lb)

AC powered: 3.6 kg (7.9 lb)

Add 0.5 kg (1.1 lb) for the terminal box.

PERFORMANCE

Resolution: 1/1000 or 0.02 mm, whichever is greater, with a deadband of 0.1 %

Insulation resistance

•AC powered (100 V AC, 200 V AC):

≥ 100 MΩ with 500 V DC

(signal or metallic housing to power)

≥ 100 MΩ with 100 V DC

(signal to metallic housing)

•AC powered (24 V AC):

≥ 100 MΩ with 100 V DC

(signal or metallic housing to power)

•DC powered (24 V DC):

≥ 100 MΩ with 100 V DC

(signal or power to metallic housing)

Dielectric strength

•AC powered (100 V AC, 200 V AC):

1500 V AC @ 1 minute

(signal or metallic housing to power)

100 V AC @ 1 minute

(signal to metallic housing)

•AC powered (24 V AC):

1500 V AC @ 1 minute

(signal or metallic housing to power)

•DC powered (24 V DC):

100 V AC @ 1 minute

(signal or power to metallic housing)

STANDARDS & APPROVALS

■ EU conformity (CE marking)

•EMC Directive

EMI EN 61000-6-4

EMS EN 61000-6-2

•Low Voltage Directive

EN 61010-1

Measurement Category II (125 V)

Reinforced insulation:

Full-open/-closed signal to other signals or power

Full-open/-closed signal to metal housing

Pollution Degree 2

•RoHS Directive

EN IEC 63000

■ UK conformity (UKCA marking)

The UK legislations and designated standards equivalent to the applicable EU directives.

TERMINOLOGY

• Overload (Lock) Protection

The Mini-Top Series is equipped with a protection circuit against overload caused by for example the valve catching an alien substance.

When an overload is detected, the Mini-Top stops supplying power to the motor and the status LED blinks in 0.5 sec. intervals.

The protection is reset automatically with applying opposite-direction input signal or turning the power off and restarting.

• Restarting Timer

The Mini-Top Series is equipped with a timer circuit which gives an interval period (0 - 10 seconds) between stop-restart actions to prevent the motor and other internal components from overheating.

It is recommended to set a long restarting time when the ambient temperature and/or the temperature of flow material is high.

• Electronic Limiter

This model is equipped with electronic limiters in order to prevent mechanical locks when the input goes below 0 % or above 100 %.

Limiters are set at approx. -0.5 % for the full-closed side, approx. 100.5 % for the full-open side.

• Seal-Spring

The Mini-top Series incorporates a seal-spring to maintain the sealing pressure when the valve is fully closed. The standard spring has 0.5 - 1 mm (.02" - .04") flexibility to facilitate the full-closed adjustment.

TERMINAL CONNECTIONS

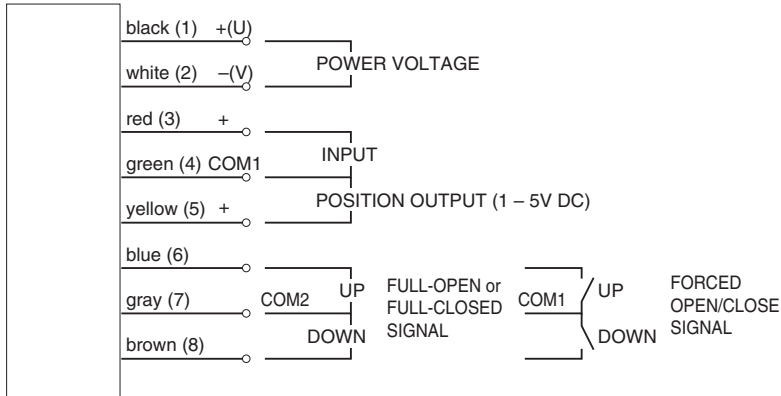

■ With Both Full-open/closed Signal and Forced Open/Close Signal

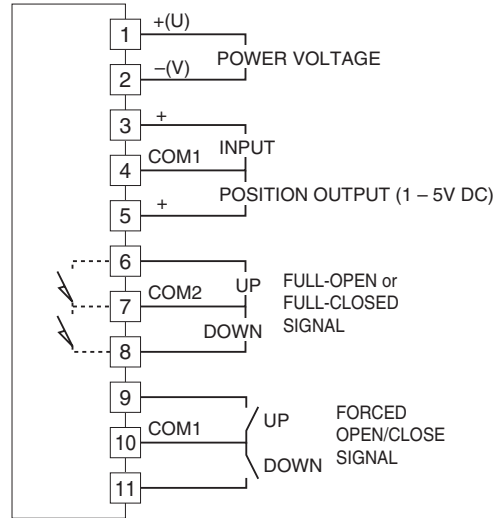

NOTE

- (1) to (8): Terminal No. of terminal box.
- Full-open/-closed signals and forced open/close signals are optional.

EXTERNAL DIMENSIONS unit: mm [inch]

■ WITHOUT TERMINAL BOX

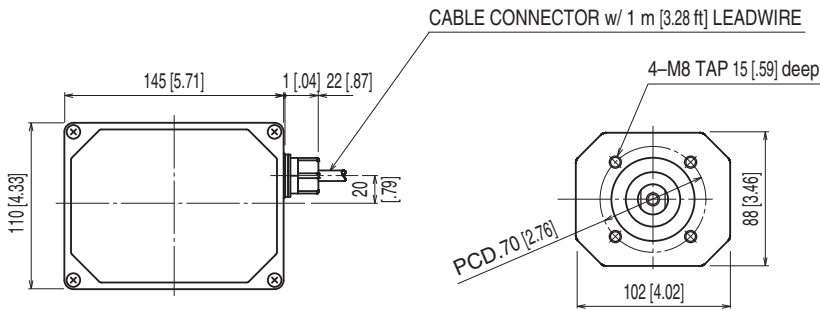

OUTPUT STEM HOLE SIZE M

CODE	DIA.	PITCH	DEPTH
6	M 6	0.75	15
8	M 8	1.0	
1	M10	1.25	
D	M 6	1.0	
E	M 8	1.25	
F	M10	1.5	

YOKE CONNECTION

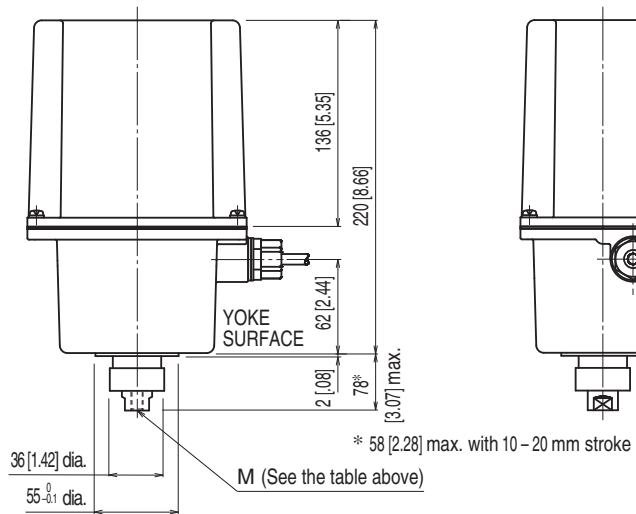

WITH TERMINAL BOX

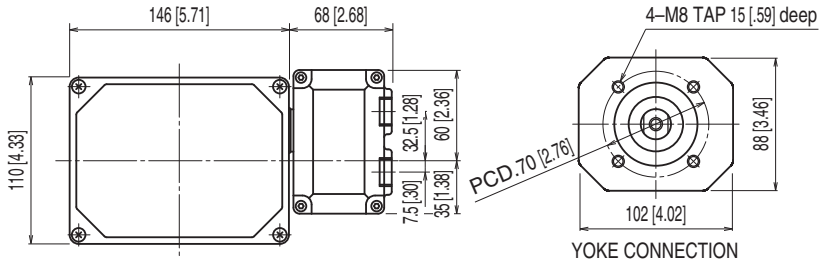

OUTPUT STEM HOLE SIZE M

CODE	DIA.	PITCH	DEPTH
6	M 6	0.75	15
8	M 8	1.0	
1	M10	1.25	
D	M 6	1.0	
E	M 8	1.25	
F	M10	1.5	

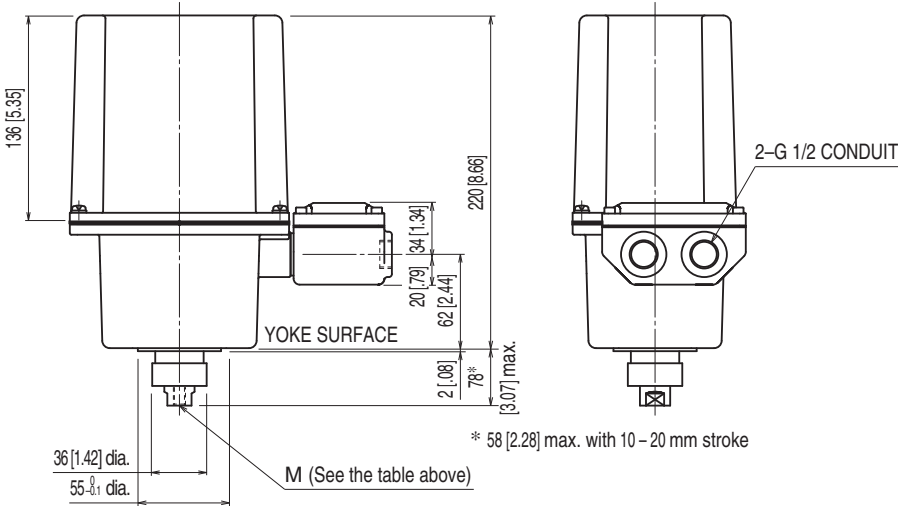

Cable connector or leadwires not provided with terminal box.

SCHEMATIC CIRCUITRY

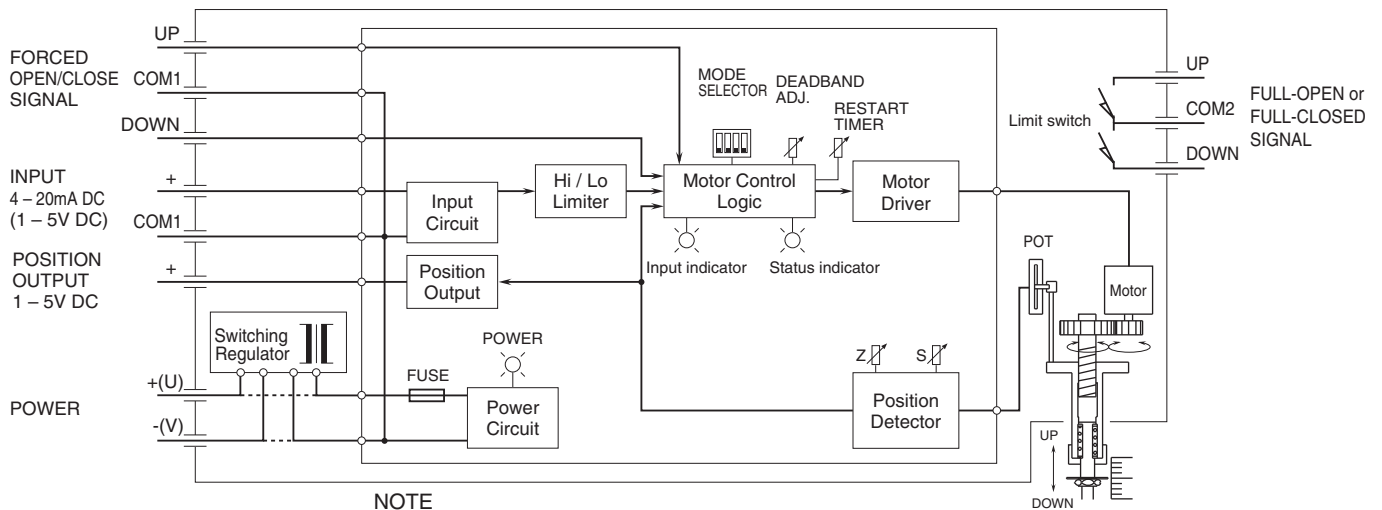

NOTE

- Full-open/-closed signals and forced open/close signals are optional.
- Disregard the switching regulator circuit for DC power input.



Specifications are subject to change without notice.