

Directional cartridge valve tight on both sides type 2URED6

NS 6 | p_{max} 35 MPa | Q_{max} 25 dm³/min | WK 433 400



DATA SHEET - OPERATION MANUAL

APPLICATION

Directional cartridge valve type 2URED6... is intended for control direction of fluid flow, causing particular movement direction or stops a receiver (cylinder or hydraulic motor). The directional valve is mounted by screwing into a threaded cavity.

The product is compliant with the regulations of directive 2014/35/UE

DESCRIPTION OF OPERATION

The directional valve type 2URED6... consists of solenoid 1, sleeve 2, poppet 3 and spring 4. Flow opening or closing is obtained by changing position of the poppet 3 inside the sleeve 2.

In version 2URED6C1... in neutral position poppet 3 opens the flow. Flow closing occurs by supplying the solenoid 1 with the voltage and moving the poppet 3. Cutting off supply voltage causes return of the poppet 3 to its starting position by means of the spring 4 and opens the flow.

In version 2URED6C5... in neutral position poppet 3 closes the flow. Flow opening occurs by supplying the solenoid 1 with the voltage and moving the poppet 3. Cutting off supply voltage causes return of the poppet 3 to its starting position by means of the spring 4 and closes the flow.

Additionally, directional valves could be supplied with manual override:

- with stroke setting by rotated knob, type **NE** (see page 2)
- with detent, type **NB** (see page 2).

TECHNICAL PARAMETERS

| | | |
|-------------------------------------|--|-------------|
| hydraulic fluid | mineral oil | |
| required fluid cleanliness class | ISO 4406 class 20/18/15 | |
| nominal fluid viscosity | 37 mm ² /s at temperature 55 °C | |
| viscosity range | 2,8 ÷ 380 mm ² /s | |
| fluid temperature range (in a tank) | recommended | 40 ÷ 55 °C |
| | max. | -20 ÷ 70 °C |
| ambient temperature range | -20 ÷ 50 °C | |
| maximum operating pressure | 25 MPa line 1 35 MPa line 2 | |
| power consumption | 26 W | |
| degree of protection | IP 65 | |
| weight | 0,32 kg | |

assembly and operation requirements at www.operating-conditions.ponar.pl

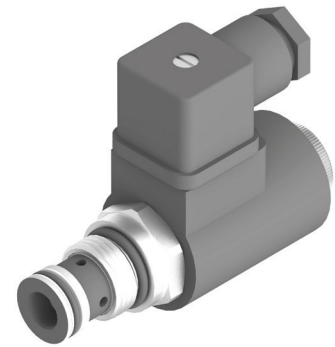

version: 2URED6C1...

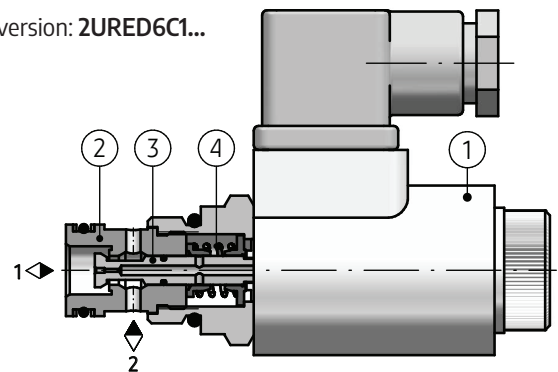

version: 2URED6C5...

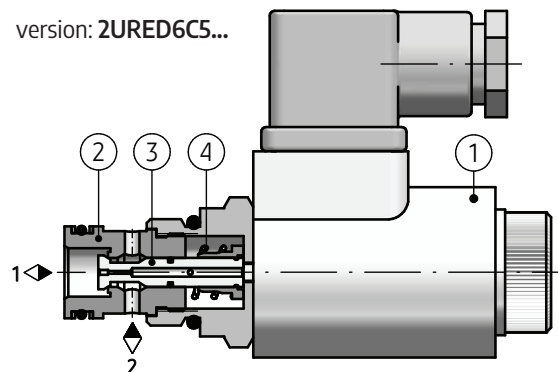

DIAGRAMS

version 2URED6C1...

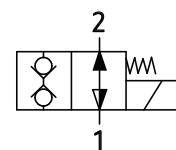

version 2URED6C5...

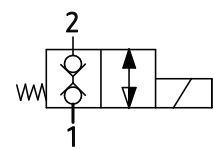

PERFORMANCE CURVES

measured at viscosity $\nu = 41 \text{ mm}^2/\text{s}$ and temperature $t = 50 \text{ }^\circ\text{C}$

Flow resistance curves

Pressure resistance Δp in relation to flow Q for directional cartridge valve type 2URED6... C1...; ...C5...

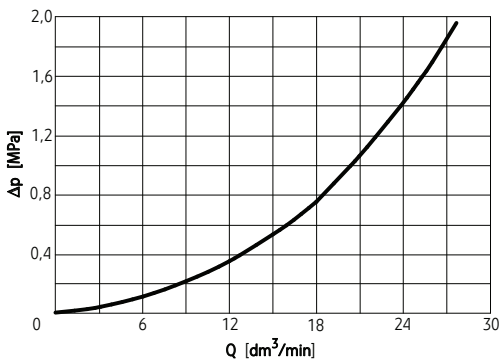

Operating limits curves

characteristic curves $p - Q$ for directional cartridge valve type 2URED6C1...; flow direction: 1 → 2 — ; 2 → 1 - -

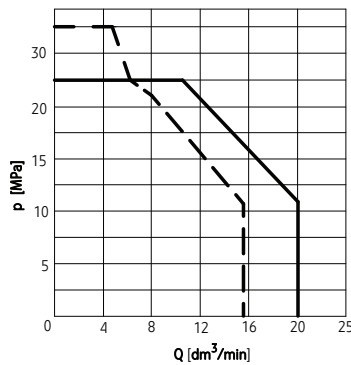

characteristic curves $p - Q$ for directional cartridge valve type 2URED6C5...; flow direction: 1 → 2 — ; 2 → 1 - -

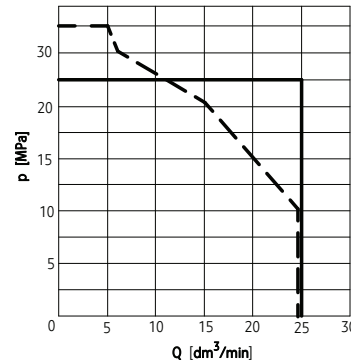

HOW TO ORDER

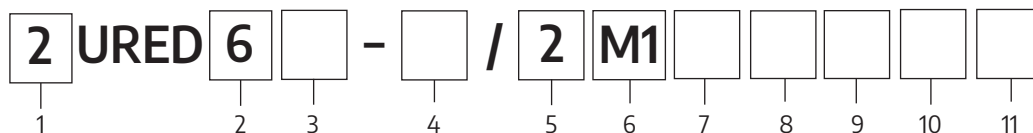

1 Number of service ports

2-way =

2

2 Nominal size (NS)

NS6 =

6

3 Spool symbol

(spool diagrams acc. to page 1)

spool ...C1... =

C1

spool ...C5... =

C5

4 Series number

(12 ÷ 19) connection and installation

dimensions unchanged =

1X

series 16 =

16

5 Number of working positions

2-position valve =

2

6 Type of connection

cavity M22 × 1,5 =

M1

7 Control voltage for solenoids

12 V DC =

G12

24 V DC =

G24

110 V AC 50 Hz (with rectifier) =

W110R

230 V AC 50 Hz (with rectifier) =

W230R

9 Electrical connection

ISO 4400 (DIN 43650-A) without LED = Z4

ISO 4400 (DIN 43650-A) with LED = Z4L

AMP Junior without plug-in connector – only for 12 V DC; 24 V DC (see pos. 7) = J

10 Sealing

NBR (for fluids on mineral oil base) = ∅

FKM (for fluids on phosphate ester

base) =

V

11 Further requirements = *

(to be agreed with the manufacturer)

NOTES:

∅ indicates that the box should be left blank.

The **symbols in bold** are the preferred versions available in short delivery time.

Coding example: **2URED6 C5 - 16 / 2 M1 G24 Z4**

Special version type 2URED6C5...- SO 478

APPLICATION, DESCRIPTION OF OPERATION, TECHNICAL DATA, DIAGRAMS, PERFORMANCE CURVES, CAVITY DIMENSIONS

as in standard version - acc. to page 1 ÷ 3

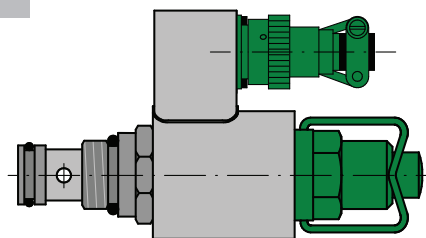

OVERALL AND CONNECTION DIMENSIONS

version: 2URED6C5...- SO 478

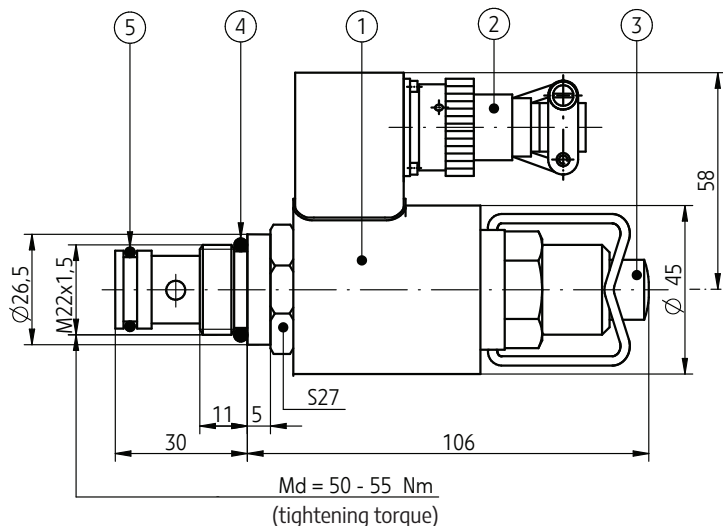

1. Solenoid with plug-in cavity type **MS3112E12-3P** (producer SOURIAU)
2. Plug-in connector type **MS3116E12-3S** (producer SOURIAU)
3. Manual override
4. O-ring 18 × 2,65
5. O-ring 15,6 × 1,78

HOW TO ORDER

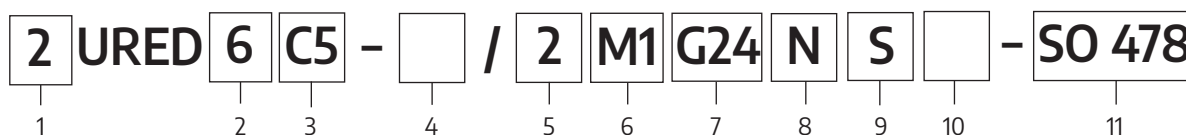

1 Number of service ports

2-way = 2

2 Nominal size (NS)

NS6 = 6

3 Spool symbol

(spool diagrams acc. to page 1)
spool ...C5... = C5

4 Series number

(12 ÷ 19) connection and installation dimensions unchanged = 1X
series 12 = 12

5 Number of working positions

2-position valve = 2

6 Type of connection

cavity M22 × 1,5 = M1

7 Control voltage for solenoids

24 V DC = G24

8 Manual override

solenoid with manual override = N

9 Electrical connection

special execution plug-in connector type MS3112E - 12 - 3P (SOURIAU) = S

10 Sealing

NBR (for fluids on mineral oil base) = ∅
FKM (for fluids on phosphate ester base) = V

11 Special execution

version with special plug-in connector and swinging clamp of manual override = **SO 478**

∅ indicates that the box should be left blank.

Directional cartridge valve should be ordered according to the above coding.

Coding example: **2URED6 C5 - 12 / 2 M1 G24 N S - SO 478**

CONTACT

PONAR Wadowice S.A.
ul. Wojska Polskiego 29
34-100 Wadowice