

DATA SHEET - Housing **GLOBTOP®** series CF

- **Dimensional:** mod. CFIA&CFXA= h197mm Ø 130mm ; mod. CFIB&CFXB= h167mm Ø 130mm
mod. CFC&CFX = h150mm Ø 130mm.
- **Conduit entries:** nr 3 (A,B,C) from ¾" NPT-F. (mod. CFIA,CFIB,CFC) ; nr 4 from ¾" NPT-F (mod. CFXA,CFXB,CFX)
- **Material:** aluminum alloy copper free (copper ≤ 0,1%) or SS 316L (except mod. CFC & CFX).
- **Casting method:** die-cast for aluminium housing and investment casting for SST housing



The term "**Copper Free**" is used to describe aluminum alloys that contain **less than 0,4% copper**. **The copper content in our housing is ≤ 0.1%** and this very low content of copper increases the strength properties of the natural corrosion of aluminum in the presence of saline atmosphere, sulfur gases and ammonium nitrate. Aluminum alloys with a level not higher than 0.1% copper, is also **required and/or recommended for installation in tropical environment** warm (40°C) – humid (90%). **Attention:** in the presence of copper increased to 0.4% (NO copper free), galvanic corrosion due to the action within the structure of the metal increases rapidly.

- **Superficial treatment:**

- ✓ **Aluminium alloy housings :** Chromate, specific for anticorrosion. Treatment in accordance with military norms MIL-DTL-5541F or a and MIL-C5541E for class 1A

This treatment generates a light yellow amorphous film, creating an excellent protection on unpainted aluminum alloy objects with a "self-healing" effect in case the film is superficially damaged or scratched, in addition to guaranteeing an optimal base for paint. The corrosion resistance in the salt spray test, is much higher than the normal passivation treatments

- ✓ **Painting** (for aluminum only): hot electrostatic with polyester powder (high adhesion) - std color. RAL 7000
- ✓ **316L SS housings:** solution heat-treatment, sand blasting, electro-polishing and passivation

These treatments, which serve to remove the superficial oxides present on the pieces in the presswork and machining phase, regenerate and improve the original rust-resistant characteristics of the object, thus adding years to its life in corrosive environments without the need for protective coatings. Excellent results in salt spray tests.

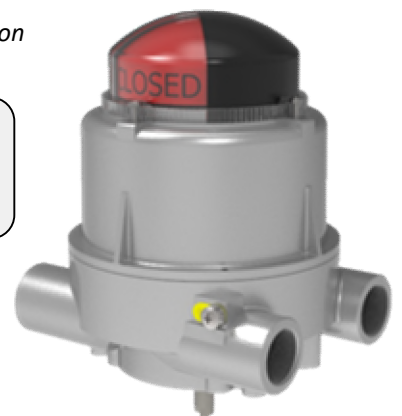

- **Protection degree:** IP66/67/67M
- **Certifications ATEX, IECEx, EAC (TR CU), INMETRO and ECAS for Exd IIC & Exia IIC area:**
Ex II 2GD - Ex db IIC T6,T5,T4 Gb – Ex tb IIIC T85/T100/T130°C Db (Tamb. da -60°C a +60/+80/+100°C)
Ex II 2GD - Ex ia IIC T6,T5,T4 Gb – Ex ia IIIC T85/T100/T130°C Db (Tamb. da -60°C a +75/+90/+100°C)
- **SIL certification:** SIL1,2,3 available according to the required configurations.
- **Mechanical coupling:** shaft and brackets for fixing according to NAMUR standard and VDI / VDE3845 (material stainless steel 316L). Wheelbases of custody fixing: 30x80mm; 57,2x57,2mm; 46x90mm

- **Visual position indicator (standard version):** material, MAKROLON® polycarbonate shock and UV resistant (excluding CFC model). Three-dimensional shape mounted on the lid (does not require disassembly in the opening / closing phase of the case).
- **Number of sensors that can be mounted inside:** from 1 up to 4(6) limit switches mechanical, magnetic and inductive of various sizes and brands.
- **Terminal strips mounting options:** up to 12 terminals of 2.5mm²

Adjustment and rotation of the vane without obstacles

T.B without obstacles to the insertion and fixing of cables

Rapid positioning and replacement of sensors

Compartment for housing input cables

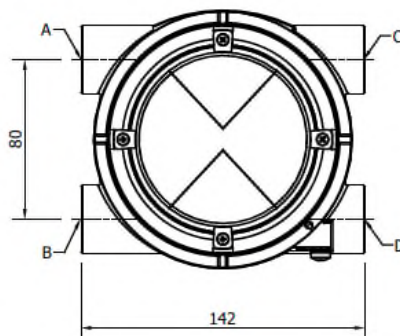
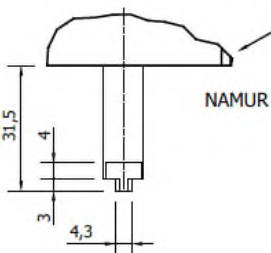
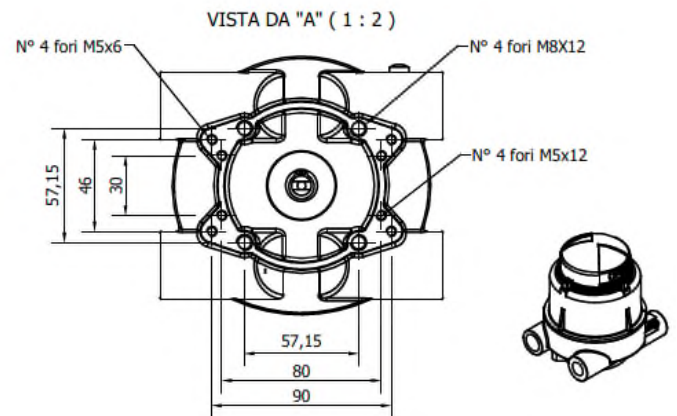
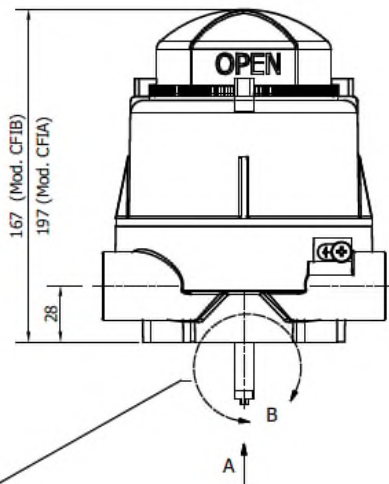
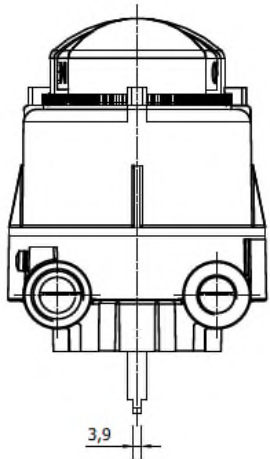
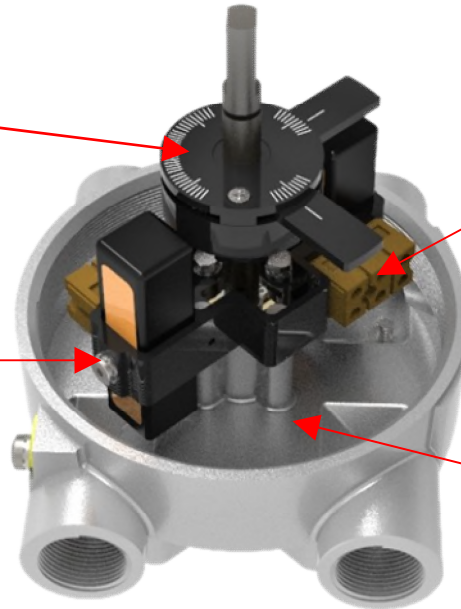

MORSETTIERA - TERMINAL BOARD					
pin	standard		pin	option	
-	switch meccanici e magnetici limit switches and magnetics	switch induttivi inductives sensors	-	switch meccanici e magnetici limit switches and magnetics	switch induttivi inductives sensors
1	N/C - ROSSO/RED	BN L +	7	N/C - ROSSO/RED	BN L +
2	C - NERO/BLACK	BK LOAD	8	C - NERO/BLACK	BK LOAD
3	N/D - BLU/BLUE	BU L -	9	N/D - BLU/BLUE	BU L -
4	N/C - ROSSO/RED	BN L +	10	N/C - ROSSO/RED	BN L +
5	C - NERO/BLACK	BK LOAD	11	C - NERO/BLACK	BK LOAD
6	N/D - BLU/BLUE	BU L -	12	N/D - BLU/BLUE	BU L -

CONFIGURAZIONE STANDARD DI FORNITURA
STANDARD CONFIGURATION FOR SUPPLY

PRODUCT CODE COMPOSITION

DIGIT 1	HOUSING MODEL
CFIB	Low cover version - Nr. 3 ¾" npt.f conduit entries - Position display in 3D (STANDARD)
CFIA	High cover version - Nr. 3 ¾" npt.f conduit entries- Position display in 3D
CFC	High cover version - Nr. 3 ¾" npt.f conduit entries
CFXB	Low cover version - Nr. 4 ¾" npt.f conduit entries- position display in 3D (STANDARD)
CFXA	Low cover version - Nr. 4 ¾" npt.f conduit entries- position display in 3D
CFX	High cover version - Nr. 4 ¾" npt.f conduit entries
NOTES: other threads available on request: ½"Npt (digit 7= _X), M20x1,5F (digit 7= _Y e M25x1,5F (digit 7= _Z)	

DIGIT 2	Nr. SENSORS
1	Nr. 1 sensor - Combined with nr.3 terminals if with SPST/SPDT contact or n° 6 if with DPDT contact
2	Nr. 2 sensors - Each with nr.3 terminals when combined with SPST/SPDT contact or n° 6 if with DPDT contact
3	Nr. 3 sensors - Each with nr. 3 terminals when combined with SPST/SPDT contact or n° 6 if with DPDT contact
4	Nr. 4 sensors - Each with nr. 3 terminals when combined with SPST/SPDT contact or n° 6 if with DPDT contact

DIGIT 3	SENSOR TYPE & POSITION TRANSMITTER
MA	Hybrid Magnetic GO switch
ME	Micro switch
IN	Inductive
RD	Magnetic JETREED
IP	4÷20mA Position Transmitter

DIGIT 4	SENSOR MODEL
MA - Magnetic GO® switch	
35H	- Mechanical contact: SPDT gold flashed. Switching capacity: 3A @ 24Vdc ; 2A @ 240Vac; resistive load. - Mechanical life cycle: about 1x10 ⁸ operations - Electrical life cycle: over 1,5x10 ⁶ operations at max. load - Operating ambient temperature: from -50°C to +105°C - (hermetically sealed model) <i>NOTES: this model replaces and is interchangeable with the sealed model 35 not longer in production</i>
7H	- Mechanical contact: DPDT palladium silver. Switching capacity: 1A @ 24Vdc ; 1,5A @ 240Vac; resistive load.- Mechanical life cycle: about 1x10 ⁸ operations - -- - Electrical life cycle: over 1,5x10 ⁶ operations at max. load - Operating ambient temperature: from -50°C to +105°C - (resin sealed model) - Digits CFIB & CFXB not included
ME Lever limit micro switch	
V15	- Mechanical contact: SPDT. Switching capacity: 10A @ 30Vdc ; 15A @ 250Vac; resistive load. - Mechanical life cycle: about 50x10 ⁶ operations - Electrical life cycle: over 1x10 ⁵ operations at maximum load - Operating ambient temperature: from -25°C to +80°C (Omron)
V3	- Mechanical contact: SPDT gold plated - Ambient operating temperature: from -60°C to 125°C - Switching capacity: from 1mA @ 4Vdc/ac to 5A @ 24Vdc/240Vac ; resistive load. (Crouzet) - Mechanical life cycle: about 2x10 ⁷ operations - Electrical life cycle: over 1,5x10 ⁵ operations at maximum load <i>NOTES: the mod. V3 Crouzet replaces and is interchangeable with the previous Honeywell V3 and Panasonic ABV versions</i>
VP	- Mechanical contact (positive break): SPDT (Specific to plants in SIS; B10d=2.10⁷; Level SIL2/3 and HFT = 0) - Switching capacity DC/AC: : from 30mA @ 10Vdc/ac to a 6A @ 24Vdc/240Vac ; resistive load - Electrical life cycle: over 1,5x10 ⁵ operations at maximum load - Ambient operating temperature: from -40°C to 85°C (Crouzet)
HS	- Mechanical contact (hermetically): SPDT - Switching capacity: 10Amp @ 30Vdc – 15Amp @ 250Vac ; resistive load.- Mechanical life cycle: about 1x10 ⁶ operations - Electrical life cycle: until 5x10 ⁵ operations at maximum load - Ambient operating temperature: from -55°C to 125°C (Honeywell)
DZ	- Mechanical contact: DPDT - Switching power: 10A @ 30Vdc – 10A @ 250Vac - Resistive load. - Mechanical life cycle: about 1x10 ⁶ operations - Electrical life cycle: until 5x10 ⁵ operations at maximum load - Operating ambient temperature: from -25°C to +80°C (Omron)

NOTES: with 3&4 micro switch please contact CE srl to define digit 1

IN - Inductives sensor	
03	Cylindrical ; namur NC ; -SIL2 ; ATEX Exia ; Tamb- 25°C + 100°C ; (mod.: NJ2 -12GK-N)
05	Rectangular; namur NC ; incorporable ; SIL2 - ATEX Exia - Tamb -25°+100°c ; (mod.: NJ2-V3-N)
13	Cylindrical; Namur NC with Safety func.; up to SIL3; EXia - Tamb - 50°C +100°C; (mod.: NJ4-12GK-SN)

RD - Magnetic JETREED®	
P1	- Reed contact: SPDT - Switching capacity: 3A, 120Vac/dc from 0,03 to 100 W /VA ; resistive load. - Mechanical life cycle: 1X10 ⁸ operations - Electrical life cycle: over 6X10 ⁵ operations at max. load - Operating ambient temperature: from -40°C a +125°C. (hermetically sealed model -IP67)

P2	- Reed contact: SPDT - Switching capacity: 3A, 240Vac/500Vdc from 3 to 100 W/VA ; resistive load. - Mechanical life cycle: 1X10 ⁸ operations - Electrical life cycle: over 6X10 ⁵ operations at max. load - Operating ambient temperature: from -25°C to +125°C - (hermetically sealed model -IP67)
P3	- Reed contact: SPDT - Switching capacity: 1A, 240Vac/dc 25 Wa/VA ; resistive load. - Mechanical life cycle: 1X10 ⁸ operations - Electrical life cycle: over 6X10 ⁵ operations at max. load - Operating ambient temperature: from -25°C to +125°C - (hermetically sealed model -IP67)
P4	- Reed contact: SPDT - Switching capacity: 3A, 240Vac/500dc from 3 to 100 W/VA ; resistive load. - Mechanical life cycle: 1X10 ⁸ operations - Electrical life cycle: over 6X10 ⁵ operations at max. load - Operating ambient temperature: from -60°C to +125°C - (hermetically sealed model -IP67)
P5	- Reed contact: SPDT gold plated - Switching capacity: 3A, 240Vac/500dc, 100 W/VA ; resistive load. - Mechanical life cycle: 1X10 ⁸ operations - Electrical life cycle: over 6X10 ⁵ operations at max. load - Operating ambient temperature: from -60°C to +125°C - (hermetically sealed model -IP67)
IP - 4÷20mA Position Transmitter	
T	Position transmitter 4-20mA with μprocessor - Calibration angle: min.0° ÷ 20°, max. 0° to 330°
H	4-20mA Position trasmitter μ processor based - HART compatible - Calibration angle range 0°÷20° min. 0°÷330° max.
OPTION	
XX	<i>To be defined according to other models, sensors can be used on request.</i>

DIGIT 5	HOUSING CERTIFICATE (SIL certificate available on request)
0	Protection IP66/67/67M
C	Atex certificate (BVI 19 ATEX 0036X): Ex II 2GD Exia IIC T6,T5,T4 Gb - Exia IIIC T85/T100/T135°C Db (T.amb. from -60°C to +75/+90/+100°C) - IP66÷67M Note: Zone 0 available on request
CE	IECEx certificate (IECEx EPS 17.0056X): Exia IIC T6,T5,T4 Gb - Exia IIIC T85°C, T100°C, T135°C Db (T.amb.max. from -60°C to +75/+90/+100°C) - IP66÷67M Note: Zone 0 available on request
C₋	Combined Exia certifications: C1 (digit C+CE) - C2 (digit C+CG) - C3 (ECAS + digit CE) - C4 (ECAS + digit C+CE) - C5 (digit CM+CE)
E	IECEx certificate (IECEx EPS 17.0057): Ex db IIC T6/T5/T4 Gb ; Ex tb IIIC T85/T100/T135°C Db (T.amb. max. from -60°C to +60/+80/+100°C) - IP66÷67M
ET	Atex certificate (BVI 19 ATEX 0006): Ex II 2 GD – Ex db IIC T6/T5/T4 Ex tb IIIC T85/T100/T135°C (T.amb. max from -60°C to +60°C /+80°C /+100°C) - IP66÷67M
E₋	Combined Exia certifications: E1 (digit E+ET) - E2 (digit ET+G) - E3 (ECAS + digit E) - E4 (ECAS + digit E+ET) - E5 (digit M+E)
G	EAC certificate (RU C-IT.HA65-B-00507-20): 1Exd IIC T6/T5/T4 Gb X – Ex td A21 T85/T100/T130°C Db X (T.amb. max -60°C to +60/+80/+100°C) - IP66÷67M
CG	EAC certificate (RU C-IT.HA65-B-00507-20): 1EXia IIC T6/T5/T4 Gb X - Exia IIIC Ta 85°C/100°C/135°C Db X (T.amb. max. from -60°C to +60/+80/+100°C) - IP66÷67M Note: Zone 0 available on request
M	INMETRO certificate (BVC22.4139): Ex db IIC T6/T5/T4 Gb ; Ex tb IIIC T85/T100/T135°C Db (T.amb. da -60°C a +60/+80/+100°C) - IP66÷67M
CM	INMETRO certificate (BVC22.4138-X): Exia IIC T6,T5,T4 Gb - Exia IIIC T85/T100/T135°C Db (T.amb. da -60°C a +75/+90/+100°C) - IP66÷67M Note: Zone 0 available on request

DIGIT 6	HOUSING MATERIAL
0	Aluminium (copper free); (STANDARD)
S	AISI 316L Stainless steel (digits CFC & CFX not included)

DIGIT 7	POSITION VISUAL DISPLAY & SPECIAL VERSION
0	Position visual display , 3D (0°– 90°) - Color: red (closed) - green (open) - Material: polycarbonate ; (STANDARD)
1	Position visual display , 3D (0°– 90°) - Color: yellow (closed) - black (open) - Material: polycarbonate
2	Position visual display , 3D , Color: yellow with graduates notches and writing Closed. Writing Open applied from 25° to 135° - Material: polycarbonate - (Recommended for linear bottom up valves)
3	Visual position indicator steel made with arrow indicator, 3D – red color
	NOTES: See ACCESSORIES for visual indicator with extension. Specific for FIREPROOF covers of actuators/valves
HOUSING SPECIAL VERSION	
_X³	½" npt.f conduit entries - Special version manufactured on request
_Y³	M20x1,5F conduit entries - Special version manufactured on request
_Z³	M25x1,5F conduit entries - Special version manufactured on request
_ _ _	Digit to be determined depending upon the special version manufactured on request

EXAMPLE COMPOSITION CODE : **CFIB - 1- MA.IP - 35H.T - ET - S - 1Y**
Digit : **1 - 2 - 3 - 4 - 5 - 6 - 7**

