



F4E 050-070 Series Spin-On Filter Assemblies

For Hydraulic and Lube Oil Applications

Features

- 200 psi (14 bar) operating pressure
- Element collapse rating of 75 psid (5 bar)
- Static burst pressure 300 psi (21 bar)
- 50 & 70 gpm (189 & 265 lpm) nominal flow rates
- Elements available with Glas-Tech® $\beta_{x(c)} \geq 1000$ media
- Optional cellulose media
- NPT or SAE straight thread ports
- Optional visual indicator
- Interchangeable with competitive spin-ons

Technical Data

Pressure & Temperature Rating

Operating Pressure:	200 psi (14 bar)
Burst Pressure:	300 psi (21 bar)
Operating Temperature:	-40°F to +250°F (-40°C to +121°C)

Materials of Construction

Head:	Aluminum
Spin-on Can:	Steel

Bypass Options

Bypass Valve Setting:	25 psid (1.7 bar) $\pm 10\%$
	3 psid (0.2 bar) $\pm 10\%$
	No bypass

Differential Pressure Indicators

Visual Indicator:	18 psid (1.2 bar) $\pm 10\%$ activation
-------------------	---

Seal Material Options

Seal Materials:	Buna
	Viton®



Elements

PTI filter elements are manufactured with the highest quality materials. PTI filter elements feature multi-layer construction for increased dirt-holding capacity and low pressure drop. PTI elements provide cost-effective contamination control for the most demanding applications. All elements are tested to the latest industry standards including ISO 16889 procedure for multipass efficiency testing.

Filtration Rating			
Multipass Test results per old ISO 4572 and new ISO 16889 test procedures			
Particle size (x) in microns at which the Beta Ratio (β) is greater than or equal to the indicated value (200 or 1000).			
	Per ISO 45729	Per ISO 16889	
Code	$\beta_x \geq 200$	$\beta_{x(c)} \geq 200$	$\beta_{x(c)} \geq 1000$
G	3	5	7
H	6	7	9
K	12	12	15
J	23	21	24

F4E filter elements are also available with 10 μ m & 25 μ m nominal water removal media and 3 μ m, 6 μ m & 25 μ m nominal cellulose media. Please refer to ordering information on back page.

Flow Rate/Pressure Drop Curves

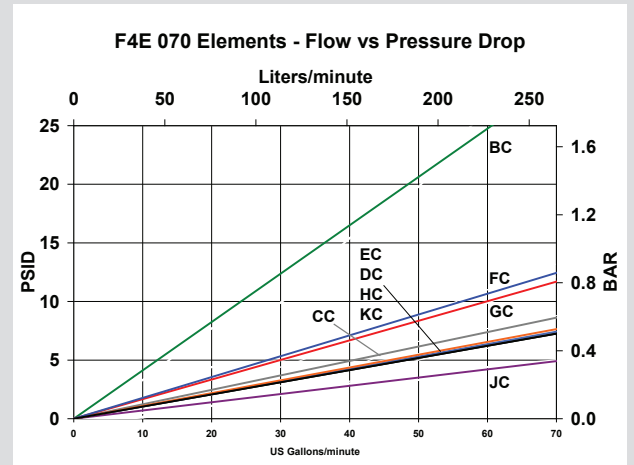
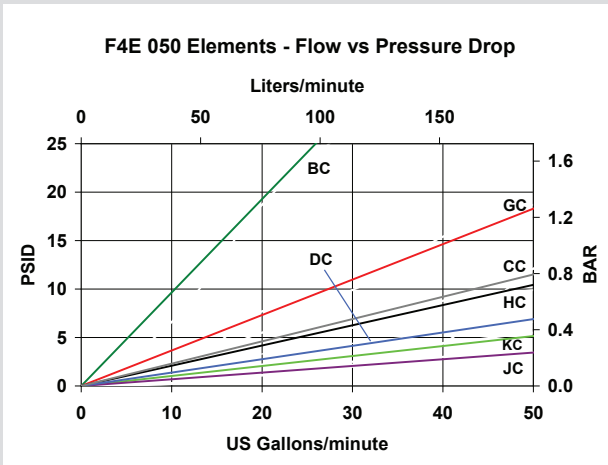
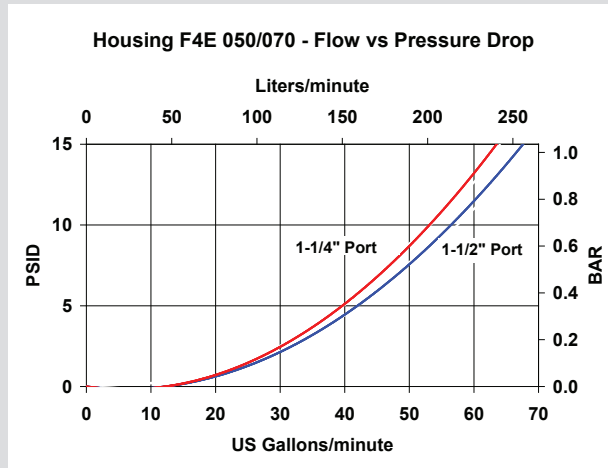

Pressure drop curves are based on 150 SUS (32 cSt) petroleum base hydraulic fluid of 0.9 S.G.

Filter Assembly ΔP = Housing ΔP + Element ΔP

Assembly Dimensions*

* Dimensions in inches (mm)

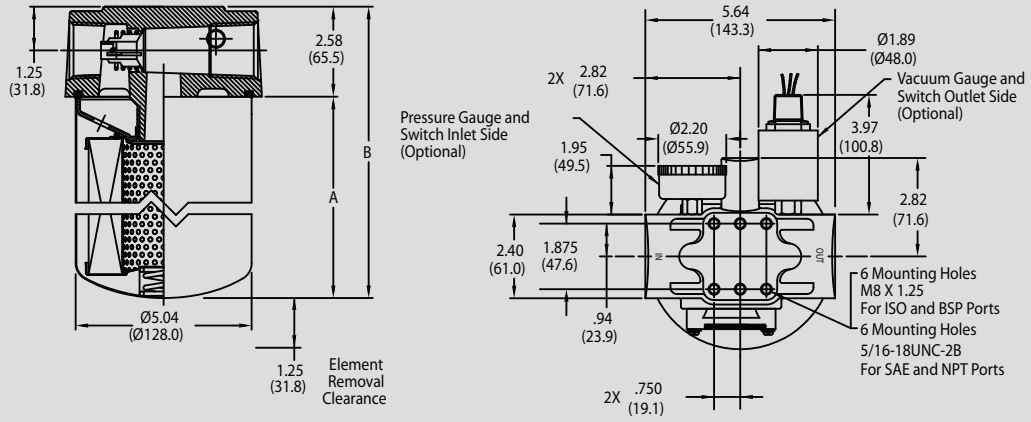

Dimensions

Nominal Flow	-050 & -051	-070 & -071
Dimension A	6.9 (175)	10.8 (268)
Dimension B	9.5 (240)	13.4 (341)

Element Dimensions*

* Dimensions in inches (mm)

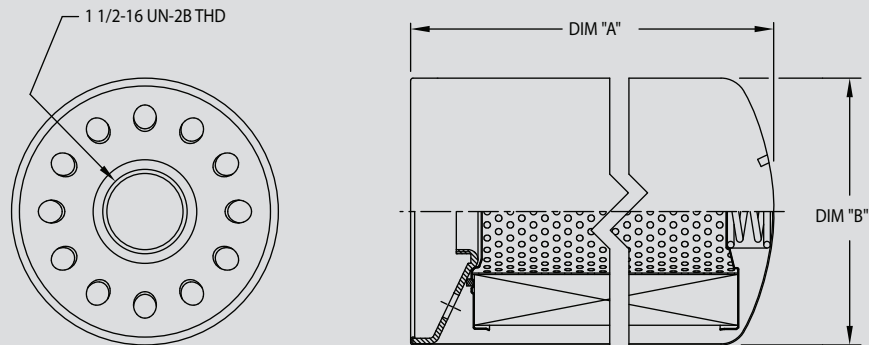

Dimensions

Nominal Flow	-050 & -051	-070 & -071
Dimension A	6.9 (175)	10.9 (279)
Dimension B	5.0 (128)	5.0 (128)

Ordering Information

Assembly:

F4E	XXX	X	X	-	X	X	X	X	X	X
TBL 1	TBL 2	TBL 3	TBL 4	TBL 5	TBL 6	TBL 7	TBL 8	TBL 9		

Table 1 Size	
Code	Nominal Flow
050	50 gpm (189 lpm)
051*	50 gpm (189 lpm)
070	70 gpm (265 lpm)
071*	70 gpm (265 lpm)

*Lip Seal Required

Table 2 Filtration Rating		
Code	Micron Rating	Media
G	$\beta_{7(c)} \geq 1000$	Glas-Tech
H	$\beta_{9(c)} \geq 1000$	Glas-Tech
K	$\beta_{15(c)} \geq 1000$	Glas-Tech
J	$\beta_{24(c)} \geq 1000$	Glas-Tech
B	3 μm	Cellulose
C	10 μm	Cellulose
D	25 μm	Cellulose
E	10 μm	Water Removal
F	25 μm	Water Removal
N	No Filter Element	

Table 3 Collapse	
Code	Collapse Rating
C	75 psid (5 bar)
N	No Filter Element

Table 4 Seals	
Code	Material
B	Buna
V**	Viton®

Viton® is a registered trademark of DuPont Performance Elastomers

**Glas-Tech elements only

Table 5 Port	
Code	Option
F	1-1/4" NPT
G	1-1/2" NPT
N	1-5/8" - 12 SAE
P	1-7/8" - 12 SAE

Table 6 Gauge Options	
Code	Option
O	None
2	Vacuum Gauge
3	Vacuum Switch
5	Color Code Gauge
6	Pressure Switch

Table 7 Indicators & Ports	
Code	Option
L	Visual 18 psid (1.2 bar) \pm 10%
3	4 x 1/8" NPT Ports
N	None

Table 8 Bypass	
Code	Option
N	Non-Bypass
C	15 psid (1 bar)
F	25 psid (1.7 bar)
R	3 psid (0.2 bar)

Table 9 Gauge Loc	
Code	Option
R ***	Right Side
L ***	Left Side
N	None

*** when looking at inlet port

Element:

F4E	-	XXX	-	X	X	-	X
TBL 1	TBL 2	TBL 3	TBL 4				

Table 1 Size	
Code	Nominal Flow
050	50 gpm (189 lpm)
051*	50 gpm (189 lpm)
070	70 gpm (265 lpm)
071*	70 gpm (265 lpm)

*Lip Seal Required

Table 2 Filtration Rating		
Code	Micron Rating	Media
G	$\beta_{7(c)} \geq 1000$	Glas-Tech
H	$\beta_{9(c)} \geq 1000$	Glas-Tech
K	$\beta_{15(c)} \geq 1000$	Glas-Tech
J	$\beta_{24(c)} \geq 1000$	Glas-Tech
B	3 μm	Cellulose
C	10 μm	Cellulose
D	25 μm	Cellulose
E	10 μm	Water Removal
F	25 μm	Water Removal

Table 3 Collapse	
Code	Collapse Rating
C	75 psid (5 bar)

Table 4 Seals	
Code	Material
B	Buna
V**	Viton®

** Glas-Tech only

Viton® is a registered trademark of DuPont Performance Elastomers