

2.40 Boschert-Chuck 40-50



- 40-50 STO** *Boschert* foot mounted chuck without shaft end
40-50 STW *Boschert* foot mounted chuck with shaft end
40-50 FLO *Boschert* flange mounted chuck without shaft end
40-50 FLW *Boschert* flange mounted chuck with shaft end



- Square bar:** □ 40 mm - 50 mm (1.5748" - 1.9685")
Standard square bar: □ 50 mm (1.9685")
max. beam weight: □ 2800 kg □ (6170 lbs)
max. torque: ↻ 1100 Nm (800 ft/lb)
max. rpm: 1350 min⁻¹

		Info
Type:	VT	2.55
	C	2.54
Journal shaft type VT:	VT1 / VT2 / VT6 / VT7	2.43
Shaft end:	Standard	2.43
Handwheel lock:	HRV II (left/right)	2.43
Special models:	90° mounting	8.01
	extended chuck	8.11
Add. parts:	brakes	6.00
	clutches	7.00

Boschert-Chuck 40-50 foot mounted



Boschert-Chuck 40-50 type VT

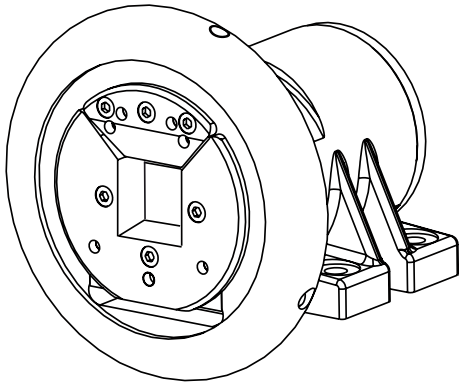

Boschert-Chuck 40-50 type C

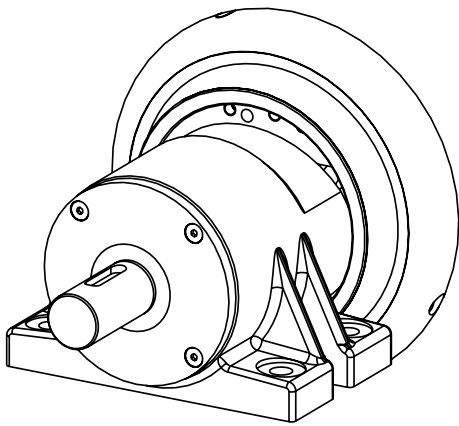
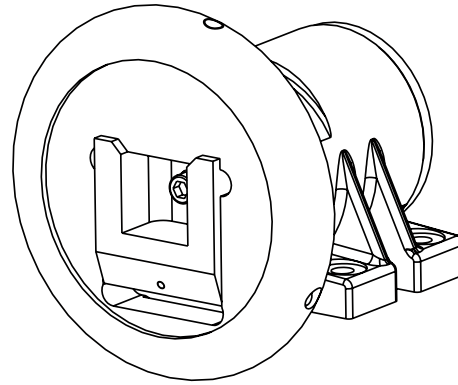

STW 40-50
chuck with shaft end

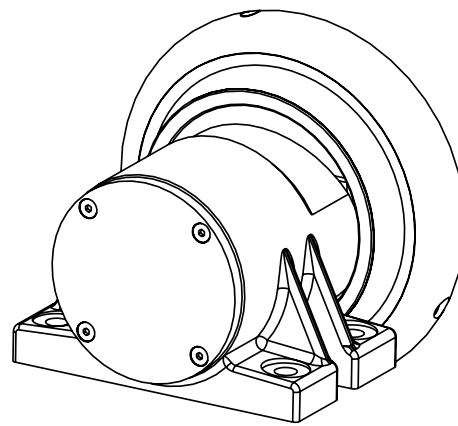

STO 40-50
chuck without shaft end

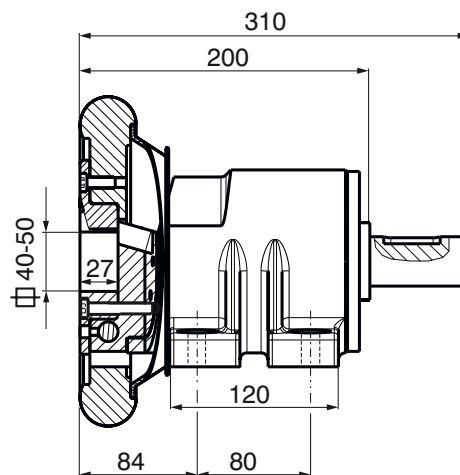
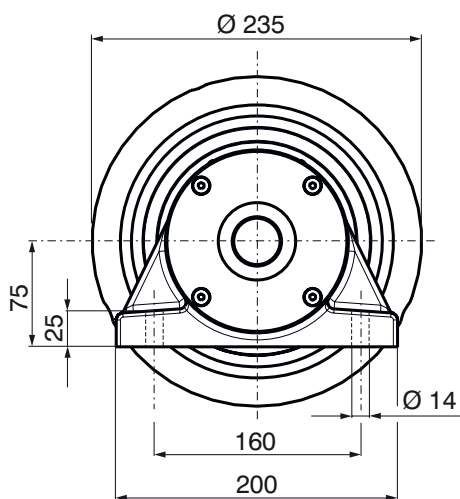

Shaft end details page 2.43

Boschert-Chuck 40-50 flange mounted



Boschert-Chuck 40-50 type VT

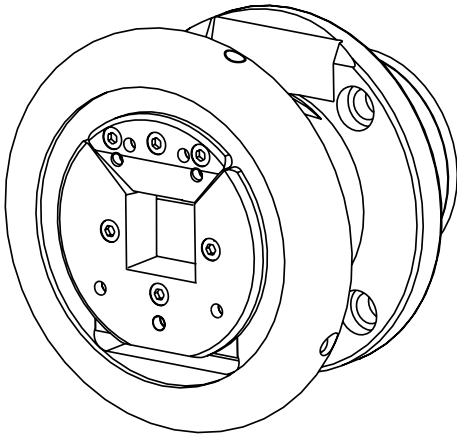

Boschert-Chuck 40-50 type C

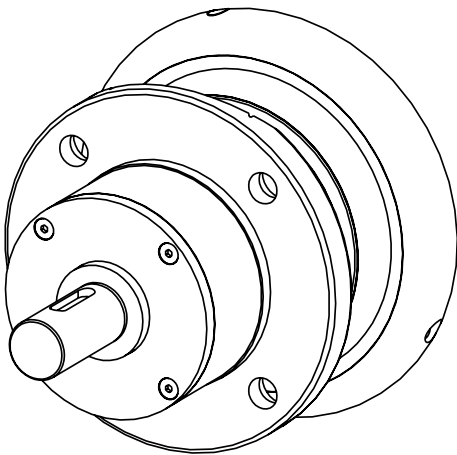
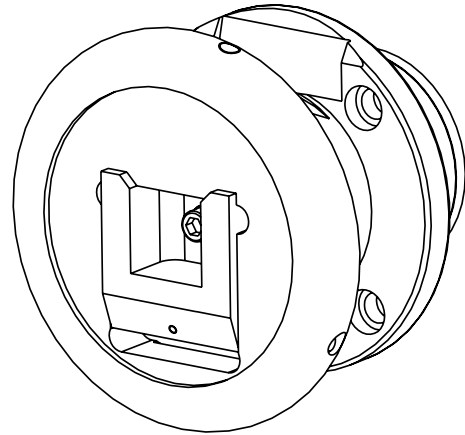

FLW 40-50
chuck with shaft end

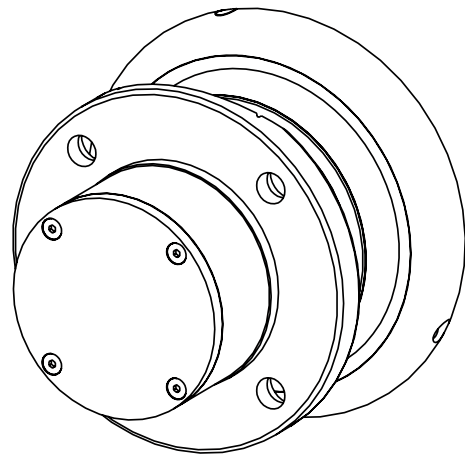

FLO 40-50
chuck without shaft end

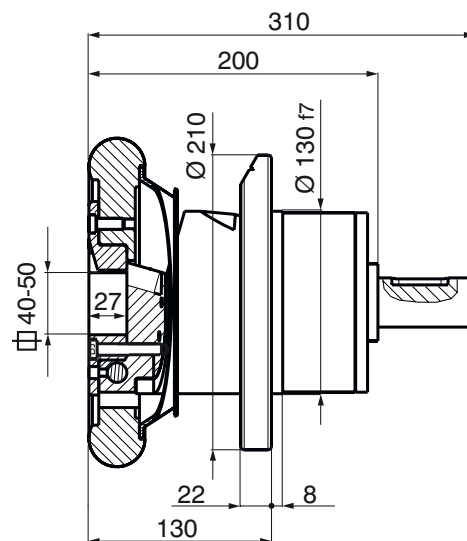
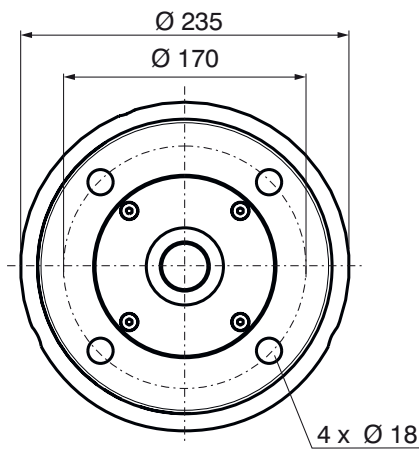

Shaft end details page 2.43

Boschert-Chuck 40-50 options



Journal shaft type

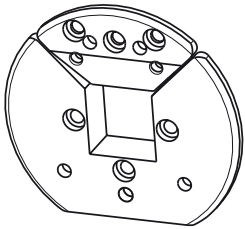

VT 1

Info: 11.10

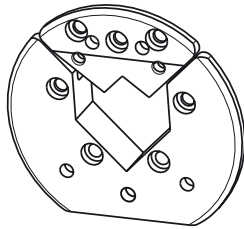

VT 2

Info: 11.10

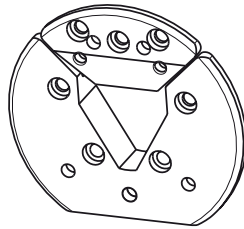

VT 6

Info: 11.11

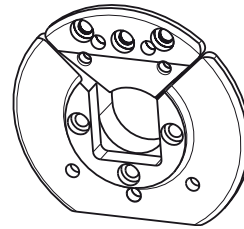

VT 7

Info: 11.12

Note at VT2 and VT7 Chucks:
 max. weight = 0.8 x catalogue value
 max. torque = 0.7 x catalogue value

Info
11.20

Shaft end

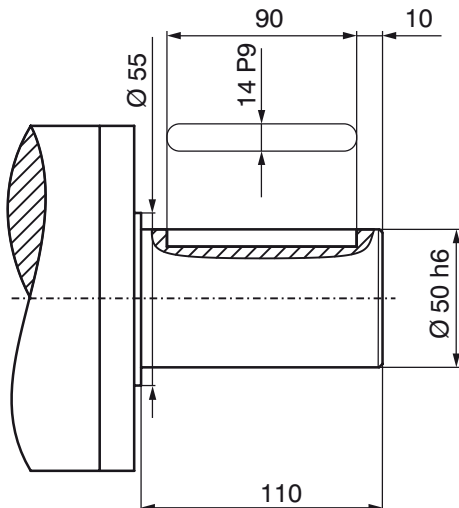

Standard shaft end

Special shaft ends per customer request

Max. shaft-dia.: Ø 65 mm
(special shaft without stop)

Handwheel lock

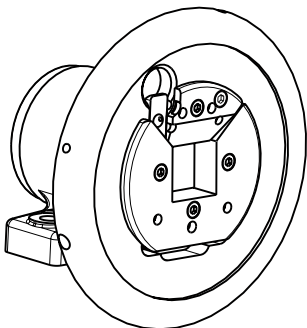

HRV II left

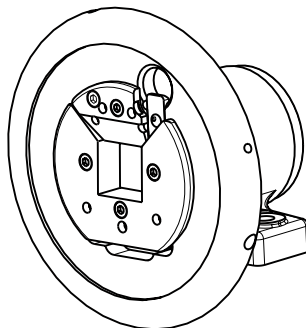

HRV II right

Info
8.30

Info
8.31

Due to safety reasons we recommend handwheel locks on applications in turret winders.

Handwheel-diameter on chucks with lock type II: Ø 250 mm