

True Union Ball Valve Type 546



General

- **Size:** 3/8"–4"
- **Material:** PVC, CPVC, PROGEF® Standard PP, ABS, SYGEF® Standard PVDF
- **Seat:** PTFE
- **Seals:** EPDM, FPM
- **End Connection:** Solvent cement socket, threaded, flanged, fusion spigot, fusion socket
- **Mounting:** Stainless steel threaded inserts
- **Standard Pack Quantity:** 1 valve

Key Certifications

- **NSF 61:** PVC and CPVC
- **FDA CFR 21 177.1520:** PP and PVDF
- **FDA CFR 21 177.2600:** EPDM and FPM
- **FDA CFR 21 177.1550:** PTFE
- **USP 25 Class VI (physiological non-toxic):** PP and PVDF
- **ABS:** All materials

Specification

The Type 546 Ball Valve shall be true union and utilize a floating ball design. The ball shall be fully molded and full port with two way blocking capability. The stem shall be blowout proof, utilizing a double o-ring seal and a predetermined break point opposite the media side of the stem seals. The seat carrier shall be adjustable and reverse threaded. The handle shall double as a seat carrier adjustment or removal tool. The valve nut threads shall be of buttress type. Ball seats shall have an elastomeric backing o-ring and all elastomeric seals shall be of like material. ANSI flanged versions shall meet ANSI B16.5 150lb standards. All valves shall be tested in accordance to ISO9393 and designed to ISO16136 standards. All valves shall be manufactured under ISO9001 for Quality and ISO14001 for Environmental Management. Following assembly, every valve shall be tested and certified bubble tight exceeding Class VI standards.

Material Specification

PVC valves shall meet ASTM D1784 cell classification 12454 standards. CPVC valves shall meet ASTM D1784 cell classification 23447-B standards. PP valves shall meet ASTM D5847-14 cell classification PP0510B66851 standards. ABS valves shall meet ASTM D3965 cell classification 42222 standards. PVDF valves shall be type 1, grade 2 according to ASTM D3222 standards. Valves of all materials shall be RoHS compliant.

Components

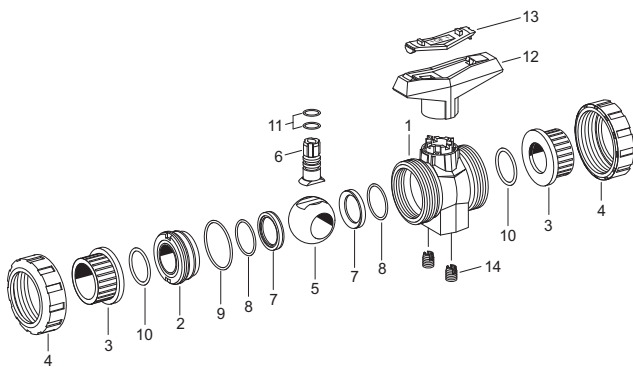

Key Design Features

The Type 546 Ball Valve comes standard with stainless steel threaded inserts for easy and secure mounting. Valves are available without inserts upon request



The Type 546 Ball Valve stem utilizes a predetermined break point opposite the media side of the stem seals. This break point is a groove with an inner diameter that is less than the stem seal grooves. This ensures that if there is a stem failure, the failure will occur at that point and media will not leak to the outside of the valve.

Optional Features

- **Actuation:** Electric, pneumatic
- **Limit Switches:** Mechanical, inductive
- **Handle:** Lockable handle, handle extension
- **Mounting pad:** Additional mounting option for valve base
- **Universal Adapter Kit:** ISO mount for actuation
- **Seals:** Alternative materials available upon request
- **Seat:** PVDF
- **End Connection:** Alternatives available upon request
- **Control Ball:** For throttling applications available 3/8"-2"
- **Vented Ball:** For sodium hypochlorite use
- **Cleaned:** Silicone free/oil free

Valve Components

Part	Description	Material
1	Valve body	PVC, CPVC, PP, ABS or PVDF
2	Seat carrier	PVC, CPVC, PP, ABS or PVDF
3	Valve end	PVC, CPVC, PP, PPn, ABS, PE or PVDF
4	Valve nut	PVC, CPVC, PP, ABS or PVDF
5	Ball	PVC, CPVC, PP, ABS or PVDF
6	Stem	PVC, CPVC, PP, ABS or PVDF
7	Seat	PTFE
8	Backing seal	EPDM or FPM
9	Body seal	EPDM or FPM
10	Face seal	EPDM or FPM
11	Stem seal	EPDM or FPM
12	Handle	Glass-filled PP
13	Handle clip	Glass-filled PP
14	Mounting insert	304 Stainless steel



The Type 546 Ball Valve seat carrier is reverse threaded while the valve nut utilizes a standard thread. This ensures that the seat carrier is not inadvertently tightened when the valve nut is tightened and avoids possible stem failures.

The valve handle doubles as a seat carrier adjustment tool by simply inserting the handle clip into the pre-molded notches on the seat carrier, making on-site maintenance quick and easy.

Technical Data

Pressure Temperature Curves

The following graphs are based on a 25 year lifetime water or similar media application

PVC

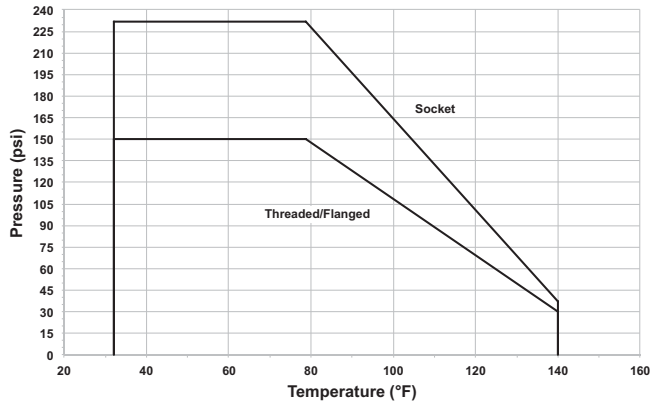

CPVC

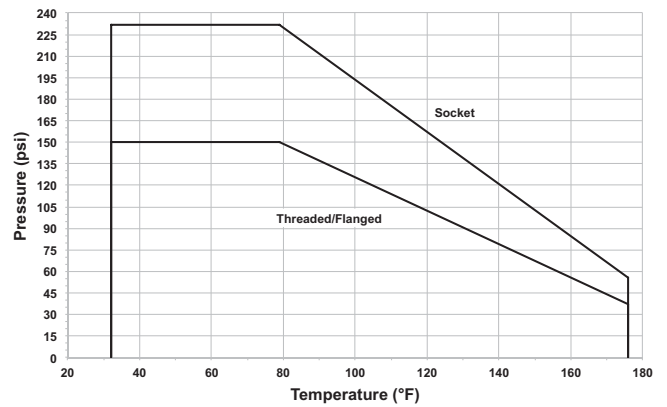

PP

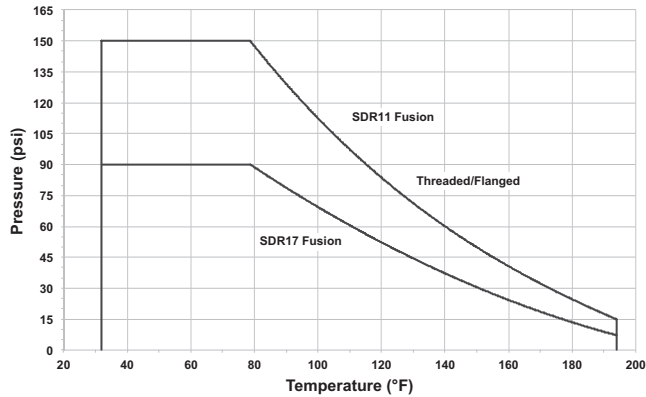

ABS

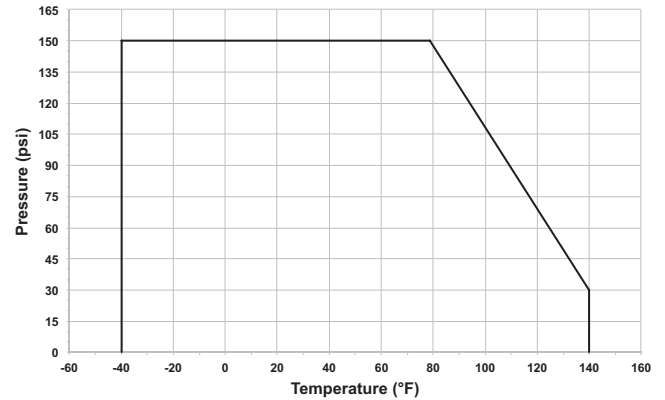

PVDF

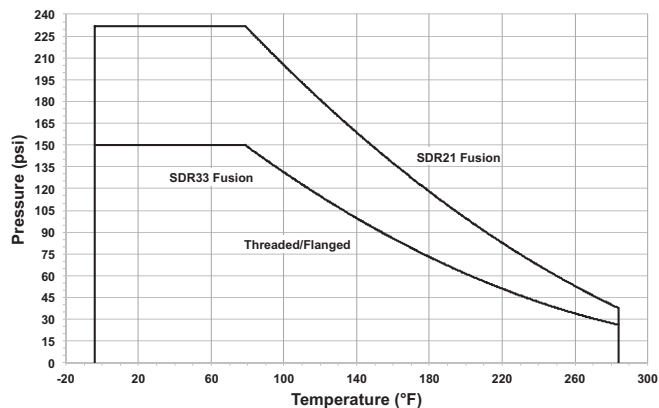

Pressure-Temperature

Material	Temperature Range (°F)	Max Pressure (psi)
PVC	32 to 140	232
CPVC	32 to 176	232
PP	32 to 176	150
ABS	-40 to 140	150
PVDF	-4 to 284	232

Vacuum Service

The Type 546 is rated for full vacuum service. Maximum differential pressure of 15psi at 122°F.

Flow

The following information is based on water applications at 68° F

Flow Characteristics

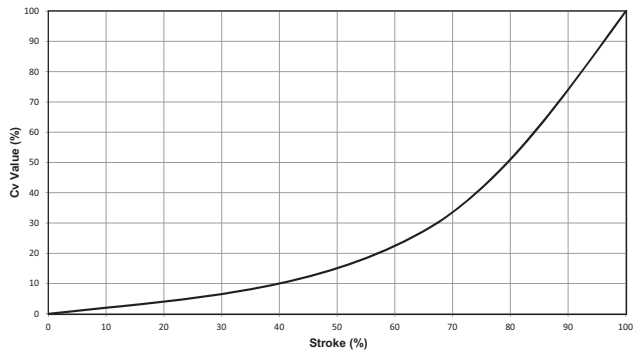

Cv Value

Size (inch)	d (mm)	Cv (gal/min)
3/8	16	5
1/2	20	13
3/4	25	25
1	32	49
1 1/4	40	70
1 1/2	50	112
2	63	217
2 1/2	75	350
3	90	490
4	110	770

Vented Ball - Optional Feature

A vented ball is an optional feature with all variations of the Type 546 Ball Valve. This version of the valve has dedicated part numbers that utilize a special ball with a 1/8 inch hole. This ball is designed for applications in which the media requires out-gassing such as sodium hypochlorite. The hole functions as a vent for media that would normally be trapped inside a closed ball. The vent prevents potentially dangerous pressure from building up inside the valve. The vent is located on the seat carrier side of the ball valve and this side is recommended to be installed upstream.

Chemical applications vary from system to system and variations such as concentration, temperature and pressure need to be considered. It is the responsibility of the individual user to verify compatibility and Georg Fischer recommends that every application be verified and tested by internal experts or a third party.



Control Ball- Optional Feature

The Type 546 Control Ball is a keyed design and is available in PVC, CPVC, PROGEF® Standard PP and SYGEF Standard® PVDF. This ball is designed for applications requiring flow control. The keyed orifice provides a nearly linear flow characteristic curve and is superior to V-notch designs. This ball is not bidirectional. The required installation direction is to have the keyed orifice downstream. The Type 546 Control Ball can be added to any Type 546 Ball Valve.

Flow Characteristics

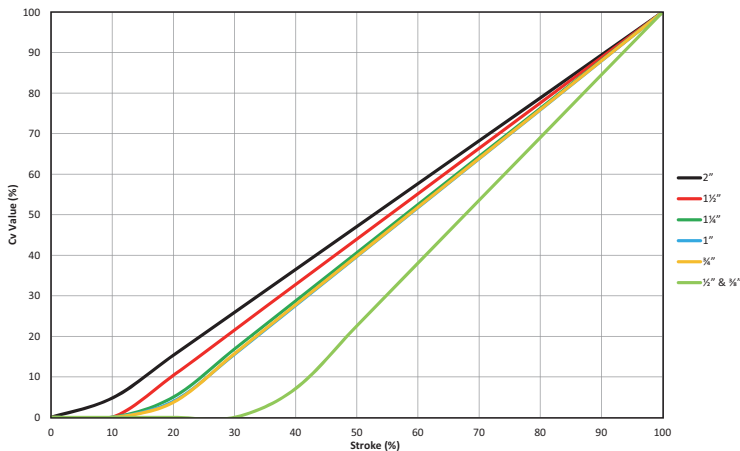

Dimensions

The following tables are shown in inches unless otherwise specified

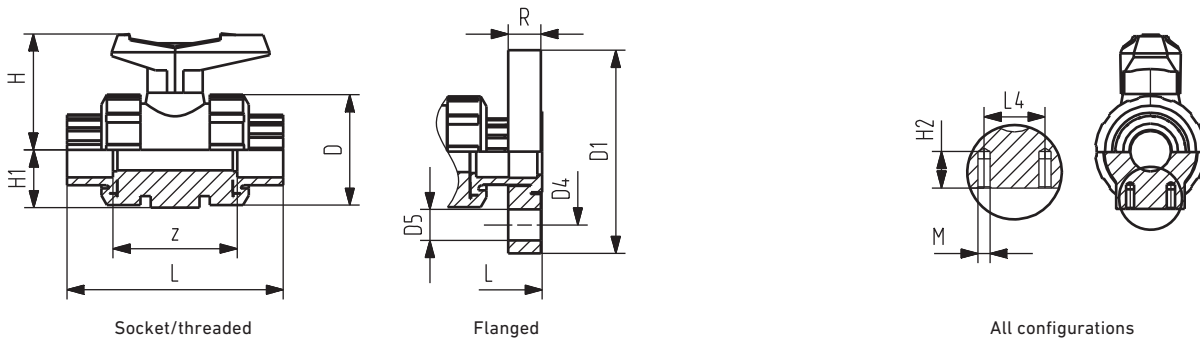

All Materials

Size	d (mm)	D	H	H1	H2	L4	M
3/8	16	1.97	2.24	1.06	0.47	0.98	M6
1/2	20	1.97	2.24	1.06	0.47	0.98	M6
3/4	25	2.28	2.64	1.18	0.47	0.98	M6
1	32	2.68	2.87	1.42	0.47	0.98	M6
1 1/4	40	3.31	3.54	1.73	0.59	1.77	M8
1 1/2	50	3.82	3.82	2.01	0.59	1.77	M8
2	63	4.88	4.57	2.52	0.59	1.77	M8
2 1/2	75	6.54	5.87	3.35	0.59	2.76	M8
3	90	7.87	6.34	4.13	0.59	2.76	M8
4	110	9.37	7.01	4.84	0.87	4.72	M12

PVC/CPVC

Size	Socket		Threaded		Flanged					
	L	z	L	z	L	D1	D4	D5	R	
3/8	4.13	2.64	3.86	2.72	-	-	-	-	-	
1/2	4.13	2.4	3.86	2.56	5.87	3.5	2.38	0.5	0.57	
3/4	4.76	2.76	4.37	2.92	6.5	3.88	2.75	0.5	0.58	
1	5.24	2.99	5	3.23	7.24	4.25	3.13	0.5	0.66	
1 1/4	6.06	3.54	5.79	3.85	8.11	4.63	3.5	0.5	0.69	
1 1/2	6.46	3.7	6.18	4.33	8.7	5	3.88	0.5	0.76	
2	7.2	4.21	7.2	5.31	9.88	6	4.75	0.63	0.82	
2 1/2	9.17	5.67	9.21	6.54	12.24	7	5.5	0.63	0.98	
3	10	5.94	10.04	6.88	13.5	7.5	6	0.63	1.02	
4	11.85	6.85	11.89	8.42	15.63	9	7.5	0.63	1.11	

ABS

d (mm)	Socket	
	L	z
16	3.62	2.52
20	3.74	2.52
25	4.33	2.83
32	4.84	3.11
40	5.57	3.7
50	6.18	3.74
63	7.2	4.21
75	9.17	5.67
90	10	5.94
110	11.85	6.85

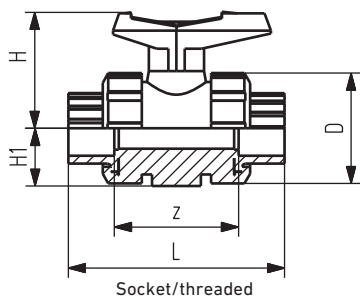

Socket/threaded

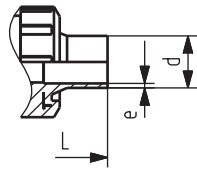

IR/butt fusion

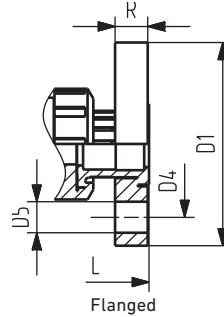

Flanged

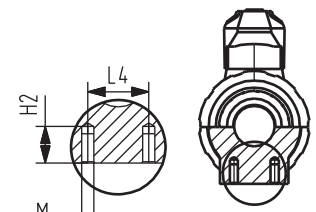

All configurations

PP

d (mm)	Socket		IR/Butt		Threaded		Flanged				
	L	z	L	e	L	z	L	D1	D4	D5	R
16	3.66	2.64	-	-	3.78	2.8	-	-	-	-	-
20	3.74	2.6	5.12	0.07	3.9	2.52	6.54	3.74	2.36	0.63	0.63
25	4.29	3.03	5.63	0.09	4.37	2.99	6.97	4.13	2.76	0.63	0.67
32	4.69	3.27	5.91	0.12	5	3.27	7.52	4.53	3.11	0.63	0.71
40	5.31	3.9	6.73	0.15	5.75	3.94	8.23	5.51	3.5	0.63	0.79
50	5.79	4.13	7.52	0.18	6.18	4.37	9.02	5.91	3.86	0.63	0.87
63	6.61	4.61	8.66	0.23	7.2	5.28	9.96	6.5	4.76	0.75	0.94
75	9.17	6.57	10.47	0.32	-	-	16.38	7.28	5.51	0.75	1.02
90	10	7.09	10.39	0.39	-	-	16.3	7.87	5.98	0.75	1.06
110	11.85	8.46	11.85	0.47	-	-	17.76	9.02	7.48	0.75	1.1

PVDF

d (mm)	Socket		IR/Butt		Threaded		Flanged				
	L	z	L	e	L	z	L	D1	D4	D5	R
16	3.66	2.64	-	-	3.78	2.72	-	-	-	-	-
20	3.74	2.6	5.12	0.07	3.9	2.52	6.85	3.74	2.36	0.63	0.63
25	4.29	3.03	5.63	0.07	4.37	2.99	7.44	4.13	2.76	0.63	0.67
32	4.69	3.27	5.91	0.09	5	3.27	7.83	4.53	3.11	0.63	0.71
40	5.31	3.9	6.73	0.09	5.75	3.98	9.25	5.51	3.5	0.63	0.79
50	5.79	4.13	7.52	0.12	6.18	4.37	9.57	5.91	3.86	0.63	0.87
63	6.61	4.61	8.66	0.12	7.2	5.31	10.28	6.5	4.76	0.75	0.94
75	9.17	6.57	10.47	0.14	-	-	16.77	7.28	5.51	0.75	1.02
90	10	7.09	10.39	0.17	-	-	16.77	7.87	5.98	0.75	1.06
110	11.85	8.46	11.85	0.21	-	-	19.17	9.02	7.48	0.75	1.1