

USA[®] TOLERANCE RINGS

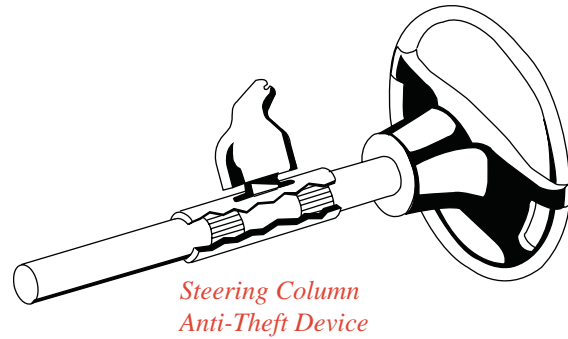

Automotive

- ABS Toner Rings
- Steering Column Anti-Theft Device
- Timing Sprocket Camshaft Connection
- Alternator Bearings
- Blower Motor Bearings



Power Tools

- Saws
- Sanders
- Routers

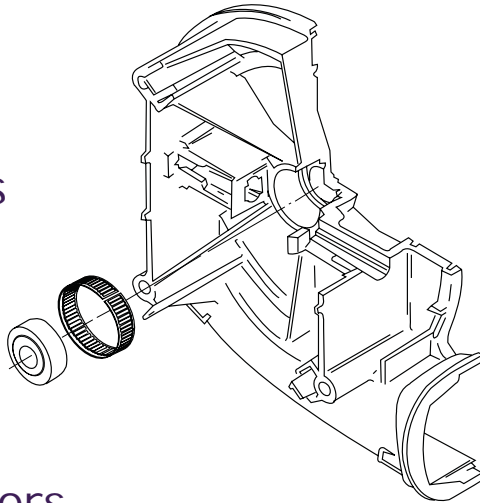

Electric Motors

- Bearings in Housings
- Bearings on Shafts
- Phenolic Brush Holder
- Rotor Tachometers on Shafts
- Fans

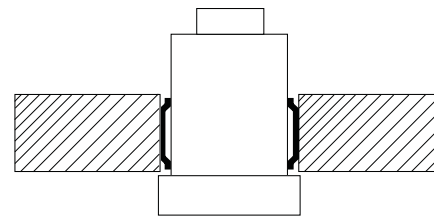

Pumps

- Ceramic Bearings and Sleeves
- Impellers
- Bearings

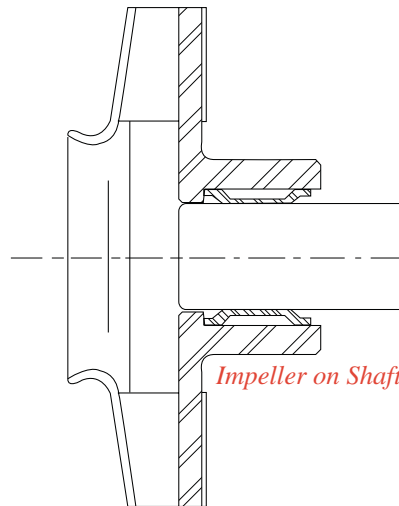

Lawn and Garden

- Rototiller Knob Mounts
- String Trimmer Bearing Mounts
- Lawn Mowers

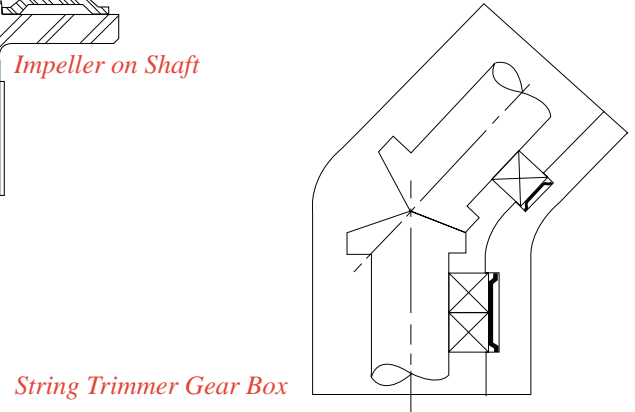

USA[®] TOLERANCE RINGS

The Company

Met any good TOLERANCE RING companies lately? Never heard of a TOLERANCE RING? We're USA TOLERANCE RINGS—an exceptional company; an exceptional product! We've been meeting design needs for American industry since 1961. Our customers include manufacturers of automobiles, home appliances, power tools, electric motors, and computer disk drives as well as many others.

TOLERANCE RINGS are tough enough to be an anti theft device on a steering column, but delicate enough to center a miniature ball bearing in a disk drive.

Our company is as flexible as our product. We respond to customers, large and small, with efficient, courteous service; with reliable and cost-effective solutions to design needs; with rapid turnaround of sample parts and with development testing in customer components. Our facility in West Trenton, New Jersey, along with our European affiliate in the United Kingdom, offers parts produced in volume to levels of extraordinary accuracy and consistency. USA TOLERANCE RINGS is the singular source for TOLERANCE RINGS in North America.

Join the ranks of the hundreds of engineers, who, when confronted with a design problem made the happy discovery of USA TOLERANCE RINGS—an exceptional company; an exceptional product.



USA TOLERANCE RINGS

85 Route 31 North
Pennington, New Jersey 08534
Toll Free: 1-877-865-7464
Telephone: 609-745-5000
Fax: 609-745-5012

Table of Contents

Introduction	4
Manufacturing Process	5
Common Uses of Tolerance Rings	6
Mounting Bearings	6
Torque Transfer	6
Differential Thermal Expansion	7
Component Fastening	7
Reclamation of Bad Parts	7
Types of Tolerance Rings	8
AN Style	8
ANL Style	8
BN Style	9
Types of Mounting	10
Centered Arrangement	10
Piloted (Half-Centered) Arrangement	10
Free Arrangement	10
Design of Mating Parts	9
Assembly Procedure Considerations	9
Operating Principle	11
Part Identification	12
Application Examples	17
AN Series Data	13
Bearing and ANL Series Data	14
BN Series Data	15
New Project Information Sheet	16



Introduction

Tolerance Rings are highly engineered frictional fasteners used to economically join mating cylindrical parts. Manufactured from high quality spring steel or stainless steel strip, Tolerance Rings are widely accepted as a fastening device capable of handling torque transfer, axial retention and radial loading between mating machine parts.

Technical and economical advantages ensured by use of Tolerance Rings include:

- Rapid, low cost assembly
- Wider dimensional tolerance of mating diameters for interference fits
- Compensation for Δ thermal expansion between mating materials
- Elimination of keys, pins, adhesives, D-shafts, threads and splines
- Compensation for small amounts of misalignment of up to $1/2^\circ$ draft angle
- Infinite rotational indexing of parts prior to assembly
- Modification to spring rates/critical frequencies of assemblies

Custom Design Flexibility

Many non-catalog parts are available from inventory and thousands of additional configurations can be made with **Standard Tooling and Standard Materials!** Why consider a special? When radial or torque capacity of a standard ring does not meet application requirements, specials are **ECONOMICAL** alternatives. Yes, even if catalog ratings are 10 times too high or 10 times too low we often can vary the stiffness by an order of magnitude simply by substituting different thicknesses of material or by adjusting the pitch which provides more or less corrugations in a ring. Therefore, if catalog stated values are only a fraction of what you need, call us for special design considerations. Simply have information per your Design Specifications form handy to speed along our response.



A Glimpse of Our Manufacturing Process

1. Begin with a strip of material of proper thickness, cut to the proper width.
2. Run the material through our tooling disks which look like special gears. This tooling determines the spacing between the corrugations (pitch), the width of the corrugations, and the corrugation height (by adjusting the centerline distance between the disks.)
3. Measure a length of corrugated strip appropriate for circumference, then cut and roll it.

It is simple to corrugate different material thicknesses on a given set of tooling, or to cut different lengths of corrugated strip to accommodate various diameters. Our limitations are that with a given pitch we have finite tooling widths available. Reference the chart on page **13** to determine the ring widths available. The width values are dependent on the pitch, not the diameter of the ring.



Common Uses of Tolerance Rings



Mounting Bearings

Tolerance Rings are ideally suited for mounting bearings since traditional installations require housing and shaft diameters to be held within a tolerance range of about 0.0005". Shaft or housing tolerances may be increased to .002", even up to .006" on larger diameters.

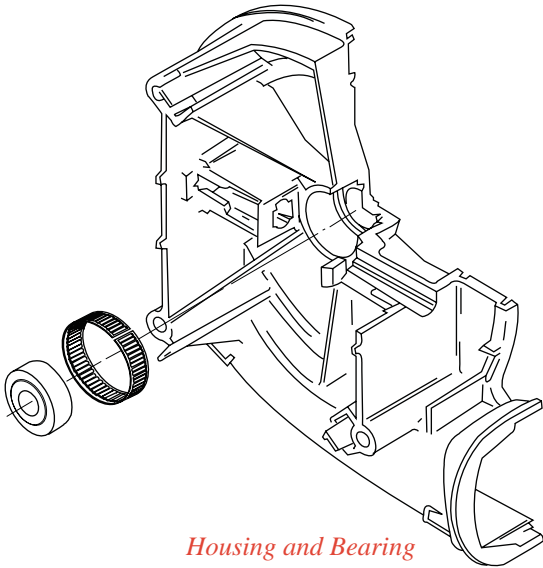

Torque Transfer

Tolerance Rings are used successfully to transmit torque from one cylindrical component to another.

Examples include mounting impellers, gears, sprockets and pulleys to shafts. The same advantages as described earlier apply for torque transfer applications—broader machining tolerances, elimination of set screws, adhesives, knurls, D-shafts and nuts. In some cases even splines may be replaced with a Tolerance Ring.

Component Fastening

Tolerance Rings are employed as fasteners for applications such as the installation of knobs onto shafts and brush holders into electric motor housings. Tolerance Rings provide positive retention and allow for infinite rotational indexing prior to assembly.

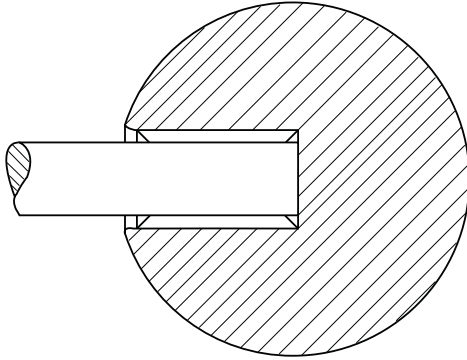

Knob

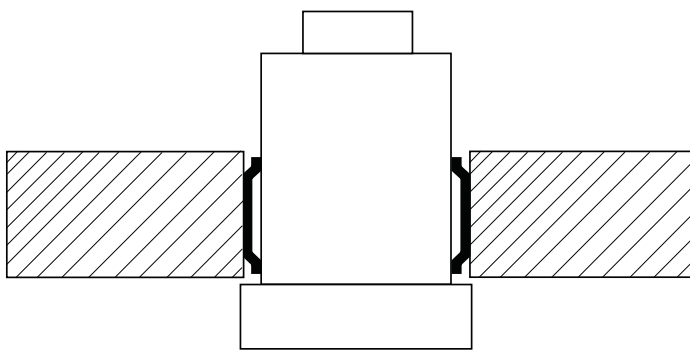

Brush Holder

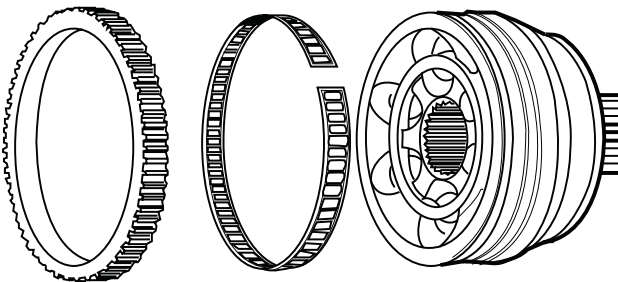

Mounting ABS Toner Rings

Reclamation of Bad Parts

Tolerance Rings are used to salvage worn housing bores or bores that have been accidentally machined oversized. Note that housing bores must be re-machined to appropriate diameters to accommodate the Tolerance Ring.



Differential Thermal Expansion

Tolerance Rings are used with great success in compensating for differential thermal expansion of mating parts. Examples include aluminum housings with steel bearings, silicon carbide bushings and sleeves mated to steel housing and shafts, and glass-filled plastic impellers to shafts. Tolerance Rings maintain retention and minimum torque values, and may accommodate wide variations in diameter without overstressing brittle components.

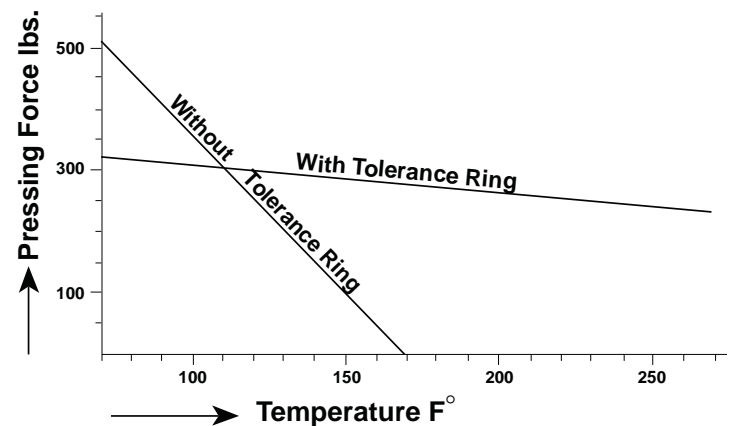

The graph above illustrates the superior performance of the Tolerance Ring in retaining a 2" diameter ball bearing in an aluminum housing. With .0012" traditional interference fit, an installation force of 500 lbs. is required. The bearing becomes loose at a temperature of 170°F. With the Tolerance Ring, an initial installation force of only 320 lbs is required, and retention remains high at 230 lbs. even at 270°F!



Types of Tolerance Rings

Tolerance Rings are made in three varieties: AN, ANL, and BN. The appropriate ring for your application will depend on such factors as assembly procedure, which part is a “nominal” diameter, and which part may be more readily modified to accept the Tolerance Ring in the design.

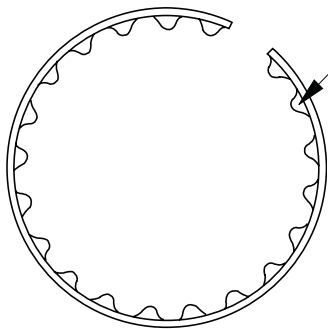

Corrugations face inward on AN and ANL rings. Corrugation heights range from .014" to .0394" for most rings.

AN Style

The AN style ring is “open” in the free state so that when installed inside a bore the ring will conform to that bore and be self retaining. If used with the centered or half-centered arrangement no further handling of the ring is necessary during assembly of the mating machine parts. When used with the free arrangement, the ring must be supported axially during assembly of the mating machine parts.

The AN style is cut to length so as to fit *outside* a “nominal” circumference. Examples for use of the AN style include mounting a bearing outer race, or mounting a fan or pulley to a shaft of common inch or metric diameter.

ANL Style

The ANL style may be described as a very light duty AN style ring. It is often characteristic of this ring to not have a circular shape in the free state.

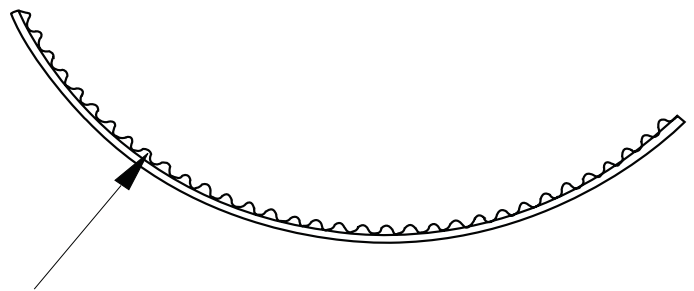

Designed for light duty, ANL rings have .014" corrugation height standard and use .004" thick material.

BN Style

BN style rings have a free-state diameter smaller than the shaft diameter over which they are to be installed, so that when mounted to the shaft the rings conform to and become self-retaining on the shaft. If used with the centered or half-centered arrangement, the ring will snap into the groove and no further handling of the ring is necessary. If used with the free arrangement, the ring must be axially supported during assembly of the mating parts.

The BN ring is cut to fit *inside* a nominal circumference. Examples for use of the BN ring include mounting a bearing inner race to a shaft, or assemblies in which modification of the shaft is more practical than modifying the bore of the outer member.

The free-state shape of the BN ring may be overlapped or may have a slight gap, but the ring should always be self-retaining to the specified shaft diameter.

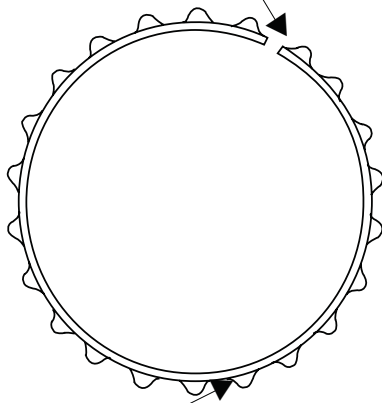

Corrugations point outward in the BN style. Corrugation heights are .0196" to .0394" for most rings.

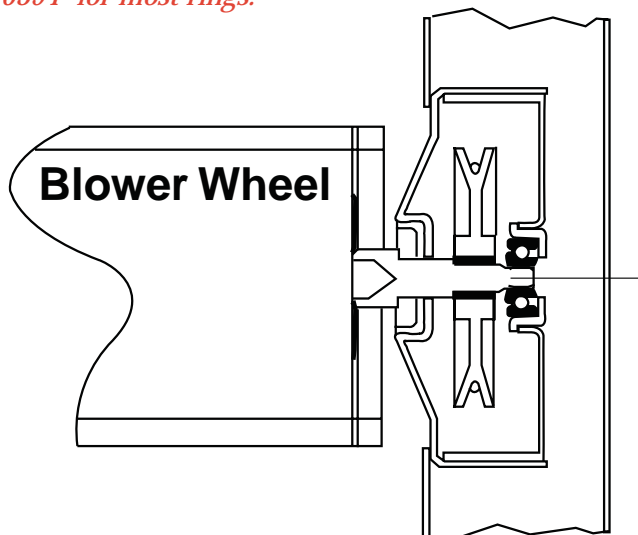

Design of Mating Parts

Assembly Procedure Considerations

The "tops" of the corrugations (The I.D. on AN style rings, or the O.D. on BN rings) are formed with a rounded contour, which assists as a lead-in edge during assembly. It is very important that the lead-in edge of the mating part is contoured with a generous radius or a shallow (15°) chamfer. Sharp corners on the lead-in edge could dig in and mar the Tolerance Ring, sacrificing performance.

Best results of assembling mating parts are achieved by using an arbor press and fixturing the parts to hold them squarely in place during assembly. Except for very light duty rings, aligning the parts by hand and/or hammering the assembly together jeopardizes alignment and performance. If misalignment occurs during assembly, there is a tendency for the lead-in edge of the mating part to flatten corrugations in one area of the Tolerance Ring, resulting in reduction of ring integrity.

Radius or chamfer are options for part which slides on corrugations during assembly.

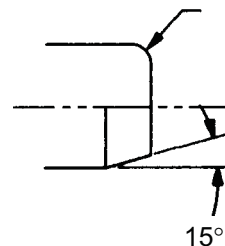

Misalignment as shown will cause flattening of corrugations in this circumferential portion of the ring.

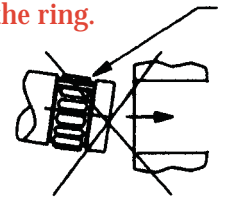

Keep Alignment True

When using the centered arrangement, a small radius and adequate groove width should be used to ensure that the Tolerance Ring may be properly seated on the cylindrical surface.

$$r_e = .010 \text{ max for dia } < 2''$$

$$= .020 \text{ max for dia } > 2''$$

$$b_{\text{min}} = (3 \times r_e) + \text{ring width}$$

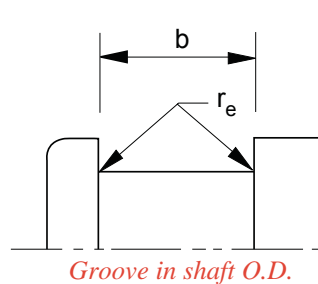

Groove in shaft O.D.

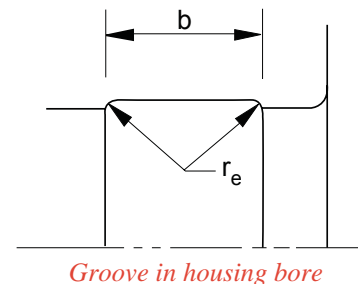

Groove in housing bore

Types of Mounting

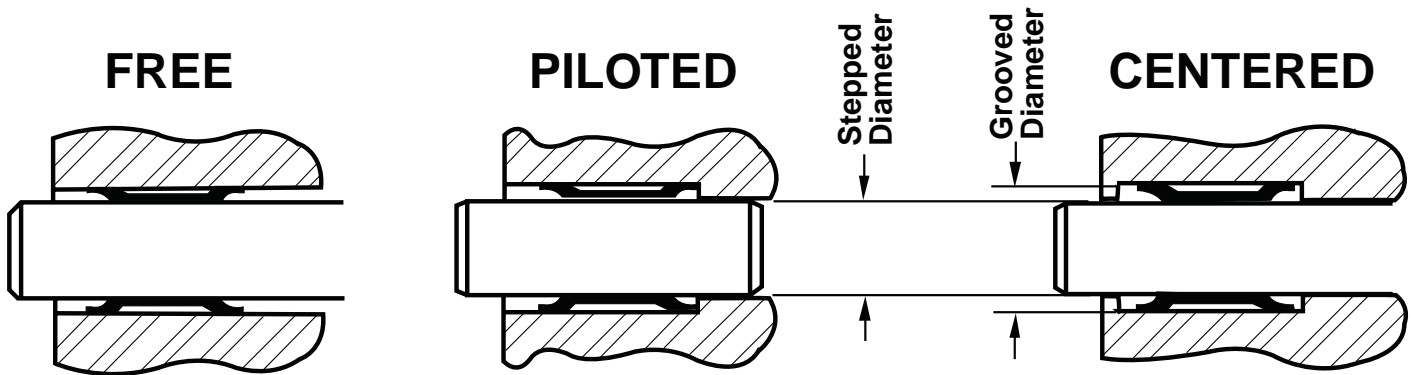

AN Ring Mounting Arrangements

Centered Arrangement

This arrangement provides a groove in the housing for AN rings or a groove in the shaft for BN rings. These grooves capture the ring axially on both sides and simplify assembly. When the shoulder (stepped) diameter is held close to the nominal diameter, the following advantages occur:

- Improved alignment of parts during installation
- Improved concentricity due to low radial clearance at the shoulder
- Excessive radial loads and shock loads can be accommodated since the Tolerance Ring is protected in its own cavity. The corrugations will deflect until the shoulder or stepped diameter contacts the mating member. Additional loading will be transmitted through the step, and will not act to further deflect or crush the corrugations.

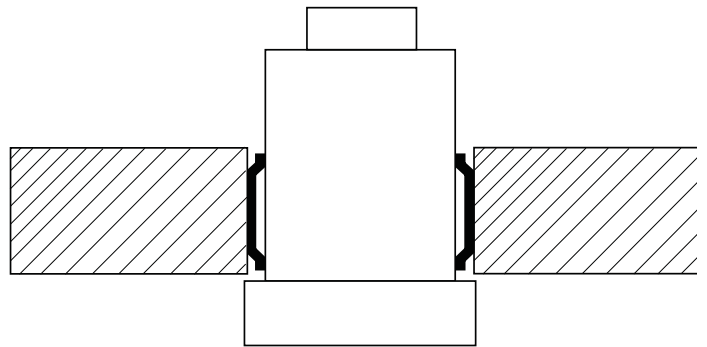

Brush Holder

Piloted (Half-Centered) Arrangement

This arrangement is similar to the centered configuration, at a lower cost. With the exception of piloting for alignment, this method may provide the advantages of the centered arrangement when the stepped diameter is held close to the nominal diameter of the mating component.

Free Arrangement

This arrangement will not provide axial support to the ring in either direction, so the assembly machine must be fixtured to “back up” or axially locate the ring temporarily while the mating components are assembled. The Tolerance Ring will be subjected to all radial loading and should be selected with appropriate capacity.

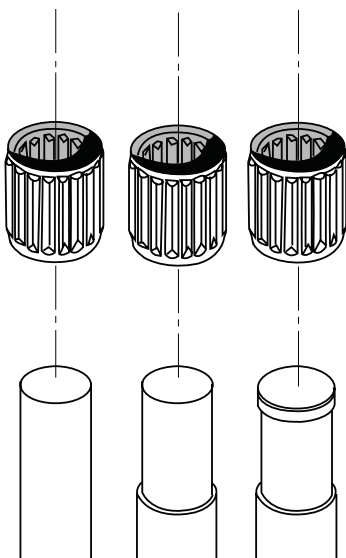



Operating Principle

Tolerance Rings work on the two physics principles of springs and friction.

Spring Formula: $F = kx$
 where F = force required to compress the spring (lbs or N)
 k = spring rate (lbs/in or N/m)
 x = distance the spring is compressed (inches or m)

Friction Formula: $F_f = cN$
 where F_f = friction force opposing movement (lbs or N)
 c = coefficient of friction
 N = force which is perpendicular to the surface.

Each corrugation (“wave” or “bump”) on a Tolerance Ring acts like a stiff radial spring. We can calculate the spring rate, k , specify the deflection, x , and estimate the coefficient of friction. All this, coupled with limits related to yield strength of the material, permits us to estimate the assembly forces, torque, and radial load capacities of a Tolerance Ring.

The load capacities, both torque and radial, vary with the amount of interference. Radial capacity is related to the yield limits of the material, the cumulative compression of the corrugations caused by interference fit plus externally applied radial loads, and the preload caused by the interference fit. Torque capacities are related to the amount of interference and coefficient of friction.

The graph below summarizes the capacities in practical terms. G1 represents the minimum diametral gap (smallest space, tightest fit) and G2 represents the maximum diametral space (biggest gap, loosest fit). Torque capacity is maximum in the tightest fit at G1 and drops to minimum at the loosest fit at G2. Radial capacity is at maximum value throughout the top half of the interference range (due to a preload effect), but drops linearly (right to left on the curve) from the midpoint to the tightest fit at G1.

The Curve Demonstrates that Maximum Torque Values and Maximum Radial Capacities Cannot Exist Simultaneously.

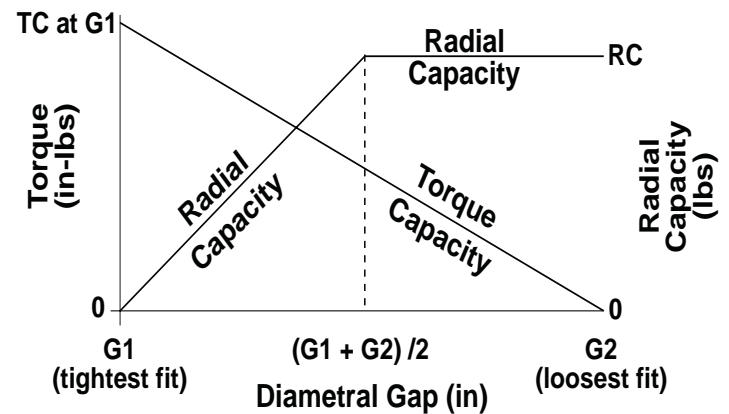

Load capacities as related to the amount of interference fit.

Part Identification Chart

BN	5	X	6	C	
AN	125		075	S	2

SERIES:
AN, ANL, BN

DIAMETER:
mm or x.xx"

INCH SERIES = blank
METRIC SERIES = X

WIDTH:
mm or x.xx"

DESIGNATES
SPECIAL DESIGN

MATERIAL:
S = 301 Stainless Steel
C = Carbon Steel
H = Hastelloy
M = Monel

SAMPLE PART NUMBER IDENTIFICATION:

BN 5 X 6 C
AN 125075 S2

BN series, 5 mm DIA, 6 mm width, carbon steel
AN series, 1-1/4" DIA, 3/4" width, stainless, special

SIZE RANGE OF STANDARD RINGS

Diameter Range	Ring Widths Available	Pitch	Material Thickness
Inch .18 / .29 mm 4.5 / 7.5	In: 1/4, 5/16, 3/8, 7/16, 1/2, 5/8 mm: 5, 6	.059" 1.5 mm	.006" .15 mm
Inch .31 / .73 mm 8 / 18	In: 1/4, 5/16, 3/8, 1/2, 5/8, 3/4 mm: 4, 5, 6, 8	.0984" 2.5 mm	.008" .2 mm
Inch .5+ mm	mm: 4, 5, 6, 7, 8, 10, 14, 15 <i>This Pitch is ANL Version Only</i>	.1236"	.004" .1 mm
Inch .70 / 1.23 mm 19 / 30	In: 1/4, 3/8, 1/2, 5/8, 3/4, 1, 1-1/8 mm: 6, 7, 8, 9, 10, 13, 16, 22	.1378" 3.5 mm	.012" .3 mm
Inch 1.25+ mm 32+	In: 1/4, 3/8, 1/2, 5/8, 3/4, 7/8, 1, 1-1/4, 1-1/2 mm: 7, 10, 11, 12, 13, 14, 15, 16, 17, 18, 19, 20, 21, 30	.1968" 5 mm	.016" .4 mm
Inch 2+ mm 52+	mm: 10, 15, 16	.248" 6.3 mm	.020" .5 mm
Inch 3+ mm 82+	mm: 19, 21	.2953" 7.5 mm	.024" .6 mm
Inch 5+ mm 125	In: 1/2, 5/8 mm: 12	.370" 9.4 mm	.028" .7 mm

AN Series

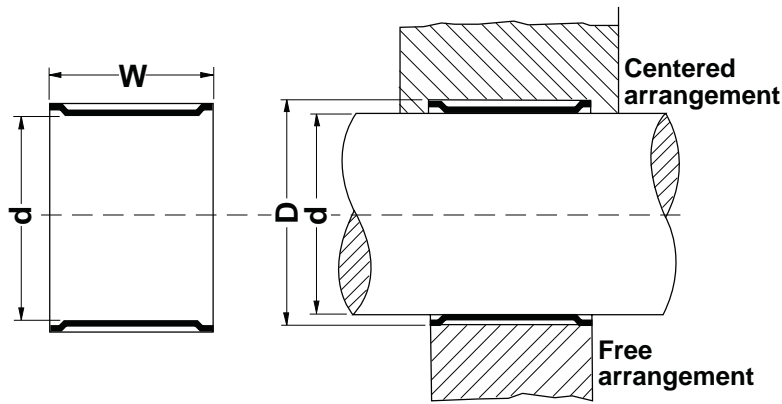

d nominal	d (in)	w2 (in)	PART NUMBER	d min (in)	D max (in)	DIAMETRAL ² CLEARANCE		RADIAL CAPACITY (lbs)	TORQUE CAPACITY @ G1 ³ (in-lbs)	TYPICAL BORE FOR TORQUE			TYPICAL BORE FOR BEARING MOUNT	
						G1 (in)	G2 (in)			TC (in-lbs)	D min (in)	D max (in)	D min (in)	D max (in)
4 mm	0.157	0.236	AN4X8C	0.156	0.195	0.032	0.039	20	3	2	0.190	0.192	0.193	0.195
3/16	0.188	0.250	AN018025C	0.187	0.226	0.032	0.039	23	4	3	0.219	0.221	0.224	0.226
6 mm	0.236	0.236	AN6X6C	0.235	0.274	0.032	0.039	30	6	4	0.269	0.270	0.273	0.274
1/4	0.250	0.250	AN025025C	0.249	0.289	0.032	0.039	45	9	4	0.283	0.285	0.287	0.289
5/16	0.313	0.250	AN031025C	0.312	0.370	0.048	0.058	65	11	7	0.362	0.364	0.368	0.370
3/8	0.375	0.250	AN037025S	0.374	0.433	0.048	0.058	190	21	15	0.424	0.426	0.430	0.433
7/16	0.438	0.250	AN043025S	0.437	0.495	0.048	0.058	230	25	18	0.487	0.489	0.492	0.495
1/2	0.500	0.250	AN050025S	0.498	0.558	0.048	0.058	270	50	25	0.549	0.552	0.555	0.558
1/2	0.500	0.750	AN050075S	0.498	0.558	0.048	0.058	810	150	75	0.549	0.552	0.555	0.558
5/8	0.625	0.250	AN062025S	0.623	0.683	0.048	0.058	320	75	37	0.674	0.677	0.680	0.683
16 mm	0.630	0.197	AN16X5S	0.628	0.688	0.048	0.058	250	58	30	0.678	0.682	0.685	0.688
11/16	0.688	0.250	AN068025S	0.686	0.746	0.048	0.058	370	100	50	0.737	0.740	0.743	0.746
19 mm	0.748	0.236	AN19X6S	0.746	0.826	0.066	0.078	420	98	60	0.814	0.817	0.823	0.826
3/4	0.750	0.250	AN075025S	0.748	0.828	0.066	0.078	440	115	70	0.816	0.819	0.825	0.828
22 mm	0.866	0.276	AN22X7S	0.864	0.944	0.066	0.078	550	220	135	0.932	0.935	0.941	0.944
7/8	0.875	0.500	AN087050S	0.873	0.953	0.066	0.078	1200	325	200	0.941	0.944	0.950	0.953
1	1.000	0.500	AN100050S	0.998	1.078	0.066	0.078	1300	425	260	1.066	1.069	1.075	1.078
28 mm	1.102	0.472	AN28X12S	1.100	1.181	0.066	0.078	1330	525	325	1.168	1.171	1.177	1.181
1 1/8	1.125	0.500	AN112050S	1.123	1.203	0.066	0.078	1440	530	330	1.188	1.192	1.199	1.203
30 mm	1.181	0.512	AN30X13S	1.179	1.259	0.066	0.078	1400	640	390	1.247	1.250	1.256	1.259
1 1/4	1.250	0.500	AN125050S	1.248	1.328	0.066	0.078	890	530	410	1.316	1.320	1.324	1.328
1 3/8	1.375	0.500	AN137050S	1.373	1.453	0.066	0.078	1040	650	500	1.441	1.445	1.449	1.453
35 mm	1.378	0.433	AN35X11S	1.376	1.456	0.066	0.078	820	550	290	1.444	1.448	1.452	1.456
1 1/2	1.500	0.500	AN150050S	1.498	1.578	0.066	0.078	1100	795	420	1.566	1.570	1.574	1.578
1 9/16	1.563	0.500	AN156050S	1.561	1.641	0.066	0.078	1100	860	460	1.629	1.633	1.637	1.641
40 mm	1.575	0.472	AN40X12S	1.573	1.653	0.066	0.078	1000	835	445	1.641	1.645	1.649	1.653
1 5/8	1.625	0.500	AN162050S	1.623	1.703	0.066	0.078	1200	940	500	1.691	1.695	1.699	1.703
42 mm	1.654	0.512	AN42X13S	1.652	1.731	0.066	0.078	1200	890	475	1.720	1.724	1.727	1.731
1 3/4	1.750	0.500	AN175050S	1.748	1.828	0.066	0.078	1200	1110	590	1.816	1.820	1.824	1.828
47 mm	1.850	0.551	AN47X14S	1.848	1.928	0.066	0.078	1400	1360	720	1.916	1.920	1.924	1.928
1 7/8	1.875	0.500	AN187050S	1.873	1.953	0.066	0.078	1300	1240	660	1.941	1.945	1.949	1.953
2	2.000	0.500	AN200050S	1.998	2.097	0.080	0.098	1100	1175	675	2.082	2.087	2.092	2.097

1. See SIZE RANGE OF STANDARD RINGS chart on page 13 for other widths which are available. Radial load and torque capacities are generally proportional to width. Performance is influenced by design of mating components and assembly procedures - actual capacities may vary from the stated values. For sizes or load requirements other than shown, contact our Engineering Department for recommendations.

2. Diametral clearance or Diametral Gap is the void where the Tolerance Ring fits (mathematically represented by D-d). The size of this gap determines the amount of interference fit. G1 and G2 are design limits.

3. Torque capacity is dependent on fit. **Torque Capacity @ G1** is the expected torque capacity at the tightest fit allowable. **TC** is the expected minimum torque transfer capacity at the Typical Bore For Torque diameter range (which occurs with Dmax).

Bearing & ANL Series

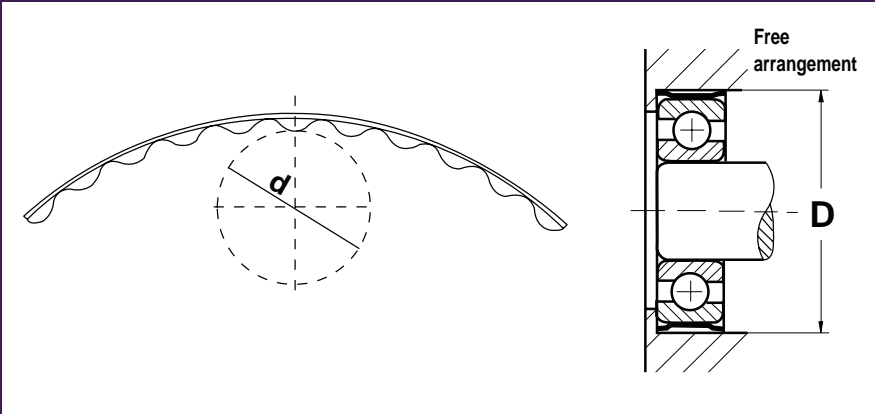

BEARING NUMBER	d Nominal	BRG O.D. d (in)	BRG W W (in)	PART NUMBER	RADIAL CAPACITY (lbs)	TYPICAL BORE FOR BEARING MOUNT		BEARING NUMBER	d nominal	BRG O.D. d (in)	BRG W W (in)	PART NUMBER	RADIAL CAPACITY (lbs)	TYPICAL BORE FOR BEARING MOUNT	
						D min (in)	D max (in)							D min (in)	D max (in)
R3	1/2	0.5000	0.1960	AN12.7X5S	180	0.555	0.558	6310	110 mm	4.3307	1.0630	AN110X25S9	7190	4.406	4.409
R4	5/8	0.6250	0.1960	AN16X5S	250	0.680	0.683	6213	120 mm	4.7244	0.9055	AN120X22S9	7190	4.799	4.802
34	16 mm	0.6299	0.1969	AN16X5S	250	0.685	0.688	6311	120 mm	4.7244	1.1417	AN120X25S9	7950	4.799	4.802
35	19 mm	0.7480	0.2362	AN19X6S	420	0.823	0.826	6214	125 mm	4.9213	0.9449	AN125X22S9	7480	4.996	4.999
38/608	22 mm	0.8661	0.2756	AN22X7S	550	0.941	0.944	6215	130 mm	5.1181	0.9843	AN130X25S9	8550	5.193	5.196
R6	7/8	0.8750	0.2500	AN087025S	580	0.950	0.953	6312	130 mm	5.1181	1.2205	AN130X31S9	10500	5.193	5.196
6000	26 mm	1.0236	0.3150	AN26X8S	770	1.098	1.101	6216	140 mm	5.5118	1.0236	AN140X25S9	9200	5.587	5.590
6001	28 mm	1.1024	0.3150	AN28X8S	840	1.177	1.181	6313	140 mm	5.5118	1.2992	AN140X33S9	12200	5.587	5.590
R8	1-1/8	1.1250	0.2500	AN112025S	720	1.199	1.203	6217	150 mm	5.9055	1.1024	AN150X25S9	9950	5.980	5.983
6200	30 mm	1.1811	0.3543	AN30X9S	980	1.256	1.259	6314	150 mm	5.9055	1.3780	AN150X33S9	13000	5.980	5.983
6201	32 mm	1.2598	0.3937	AN32X10S	670	1.334	1.338	6218	160 mm	6.2992	1.1811	AN160X25S9	10550	6.374	6.377
6202/6300	35 mm	1.3780	0.4331	AN35X11S	820	1.452	1.456	6315	160 mm	6.2992	1.4567	AN160X33S9	13950	6.374	6.377
6301	37 mm	1.4567	0.4724	AN37X12S	900	1.531	1.535	6316	170 mm	6.6929	1.5354	AN170X39S9	17250	6.767	6.770
6203	40 mm	1.5748	0.4724	AN40X12S	1000	1.649	1.653	6317	180 mm	7.0866	1.6142	AN180X39S9	19000	5.161	7.164
6302	42 mm	1.6535	0.5118	AN42X13S	1200	1.727	1.731	6318	190 mm	7.4803	1.6929	AN190X39S9	20500	7.555	7.558
ANL RINGS															
BEARING NUMBER	d nominal	BRG O.D. d (in)	BRG W W (in)	PART NUMBER	RADIAL CAPACITY (lbs)	TYPICAL BORE FOR BEARING MOUNT		BEARING NUMBER	d nominal	BRG O.D. d (in)	BRG W W (in)	PART NUMBER	RADIAL CAPACITY (lbs)	TYPICAL BORE FOR BEARING MOUNT	
						D min (in)	D max (in)							D min (in)	D max (in)
R3	1/2	0.5000	0.1960	ANL12.7X5S	6	0.525	0.527	R3	1/2	0.5000	0.1960	ANL12.7X5S	6	0.525	0.527
R4	5/8	0.6250	0.1960	ANL16X5S	8	0.650	0.652	R4	5/8	0.6250	0.1960	ANL16X5S	8	0.650	0.652
34	16 mm	0.6299	0.1969	ANL16X5S	8	0.655	0.657	34	16 mm	0.6299	0.1969	ANL16X5S	8	0.655	0.657
6210	11/16	0.6875	0.3125	ANL17.5X8S	11	0.714	0.716	21104	11/16	0.6875	0.3125	ANL17.5X8S	11	0.714	0.716
35	19 mm	0.7480	0.2362	ANL19X6S	10	0.773	0.775	35	19 mm	0.7480	0.2362	ANL19X6S	10	0.773	0.775
608/38	22 mm	0.8661	0.2756	ANL22X7S	13	0.890	0.892	608/38	22 mm	0.8661	0.2756	ANL22X7S	13	0.890	0.892
608/38	22 mm	0.8661	0.2756	ANL22X10S	21	0.890	0.892	608/38	22 mm	0.8661	0.2756	ANL22X10S	21	0.890	0.892
6203	40 mm	1.5748	0.4724	ANL40X12S	45	1.600	1.602	6203	40 mm	1.5748	0.4724	ANL40X12S	45	1.600	1.602

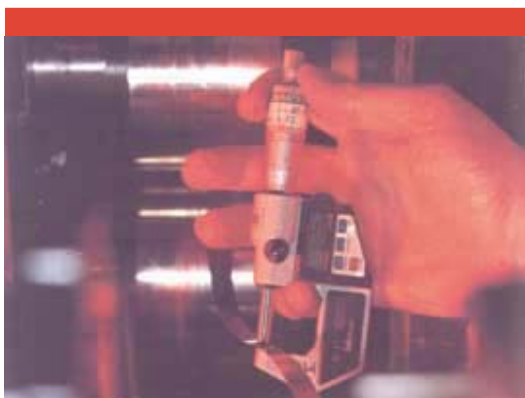

1. Recommended bore sizes assume no differential thermal expansion (going looser). Radial Capacity is a static load rating.
2. USA Tolerance Rings may also be used to mount inner bearing races to shafts (BN series). Please contact our engineers to review these applications since they usually involve cyclical loading rather than static loads.
3. These part numbers are for "Free Arrangement" mounting configurations (REF p. 10). Assemblies using narrow, light-duty rings and a centered arrangement benefit from lighter assembly forces while still preventing bearing race rotation. Consult our Sales or Engineering Department for recommendations.

BN Series

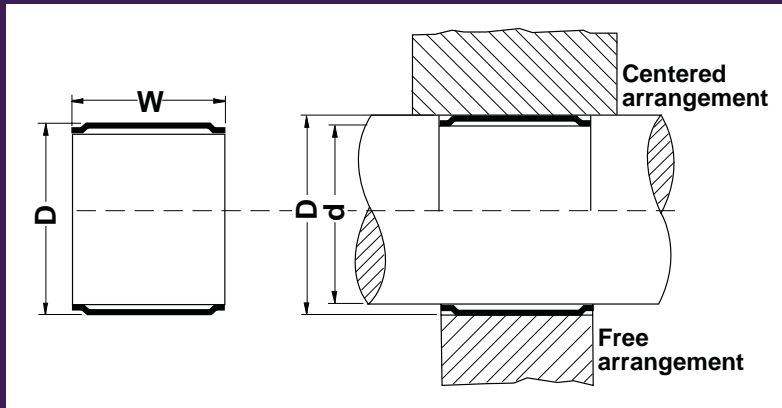

D nominal	D (in)	W ¹ (in)	PART NUMBER	d min (in)	D max (in)	DIAMETRAL ² CLEARANCE		RADIAL CAPACITY (lbs)	TORQUE CAPACITY @ G1 ³ (in-lbs)	TYPICAL O.D. FOR TORQUE			TYPICAL O.D. FOR BEARING MOUNT	
						G1 (in)	G2 (in)			TC (in-lbs)	d min (in)	d max (in)	d min (in)	d max (in)
3/16	0.188	0.250	BN018025C	0.149	0.189	0.032	0.039	50	3	1.8	0.153	0.155	0.149	0.150
5 mm	0.197	0.236	BN5X6C	0.159	0.198	0.032	0.039	50	3	2	0.162	0.164	0.159	0.160
6 mm	0.236	0.236	BN6X6C	0.198	0.237	0.032	0.039	85	4	2	0.201	0.203	0.198	0.200
1/4	0.250	0.250	BN025025C	0.211	0.251	0.032	0.039	105	7	4	0.215	0.217	0.211	0.213
5/16	0.313	0.250	BN031025C	0.254	0.314	0.048	0.058	55	11	8	0.262	0.264	0.254	0.256
8 mm	0.315	0.197	BN8X5S	0.257	0.316	0.048	0.058	125	9	5	0.264	0.266	0.257	0.259
3/8	0.375	0.250	BN037025S	0.317	0.376	0.048	0.058	190	21	12	0.323	0.326	0.317	0.320
10 mm	0.394	0.276	BN10X7S	0.336	0.395	0.048	0.058	200	24	17	0.342	0.345	0.336	0.339
12 mm	0.472	0.197	BN12X5S	0.414	0.473	0.048	0.058	200	31	18	0.420	0.423	0.414	0.417
1/2	0.500	0.250	BN050025S	0.442	0.501	0.048	0.058	240	37	21	0.448	0.451	0.442	0.445
9/16	0.563	0.250	BN056025S	0.505	0.564	0.048	0.058	240	47	28	0.511	0.514	0.505	0.508
15 mm	0.591	0.236	BN15X6S	0.532	0.592	0.048	0.058	270	49	30	0.539	0.542	0.532	0.535
5/8	0.625	0.250	BN062025S	0.567	0.627	0.048	0.058	300	75	38	0.573	0.576	0.567	0.570
17 mm	0.669	0.472	BN17X12S	0.611	0.671	0.048	0.058	640	185	92	0.617	0.620	0.611	0.614
11/16	0.688	0.375	BN068037S	0.629	0.690	0.048	0.058	510	160	80	0.636	0.639	0.629	0.632
3/4	0.750	0.500	BN075050S	0.672	0.752	0.066	0.078	880	200	120	0.681	0.684	0.672	0.675
20 mm	0.787	0.472	BN20X12S	0.710	0.789	0.066	0.078	840	175	110	0.718	0.721	0.710	0.713
7/8	0.875	0.500	BN087050S	0.797	0.877	0.066	0.078	1000	300	185	0.806	0.809	0.797	0.800
15/16	0.938	0.500	BN093050S	0.859	0.940	0.066	0.078	1125	405	245	0.869	0.872	0.859	0.862
25 mm	0.984	0.472	BN25X12S	0.907	0.986	0.066	0.078	1100	275	170	0.915	0.918	0.907	0.910
1	1.000	0.500	BN100050S	0.922	1.002	0.066	0.078	1200	400	245	0.931	0.934	0.922	0.925
1 1/8	1.125	0.500	BN112050S	1.047	1.127	0.066	0.078	1300	515	315	1.056	1.059	1.047	1.050
30 mm	1.181	0.512	BN30X13S	1.104	1.183	0.066	0.078	1400	550	340	1.112	1.115	1.104	1.107
1 3/16	1.188	0.875	BN118087S	1.109	1.190	0.066	0.078	2500	1150	700	1.119	1.122	1.109	1.112
1 1/4	1.250	0.750	BN125075S	1.172	1.252	0.066	0.078	1200	740	450	1.181	1.184	1.172	1.175
1 3/8	1.375	0.688	BN137068S	1.297	1.377	0.066	0.078	1170	770	410	1.305	1.309	1.297	1.301
35 mm	1.378	0.669	BN35X17S	1.300	1.380	0.066	0.078	1220	785	415	1.308	1.312	1.300	1.304
1 1/2	1.500	0.750	BN150075S	1.422	1.502	0.066	0.078	1500	1120	595	1.430	1.434	1.422	1.426
40 mm	1.575	0.551	BN40X14S	1.497	1.577	0.066	0.078	1200	850	450	1.505	1.509	1.497	1.501
1 5/8	1.625	1.000	BN162100S	1.547	1.627	0.066	0.078	2200	1800	955	1.555	1.559	1.547	1.551
1 3/4	1.750	1.000	BN175100S	1.672	1.752	0.066	0.078	2400	2100	1115	1.680	1.684	1.672	1.676
2	2.000	1.000	BN200100S	1.922	2.002	0.066	0.078	2700	2900	1775	1.931	1.934	1.922	1.926

1. See SIZE RANGE OF STANDARD RINGS chart on page 13 for other widths which are available. Radial load and torque capacities are generally proportional to width. Performance is influenced by design of mating components and assembly procedures - actual capacities may vary from the stated values. For sizes or load requirements other than shown, contact our Engineering Department for recommendations.

2. Diametral clearance or Diametral Gap is the void where the Tolerance Ring fits (mathematically represented by D-d) The size of this gap determines the amount of interference fit. G1 and G2 are design limits.

3. Torque capacity is dependent on fit. **Torque Capacity @ G1** is the expected torque capacity at the tightest fit allowable. **TC** is the expected minimum torque transfer capacity at the Typical Bore For Torque diameter range (which occurs with Dmax).

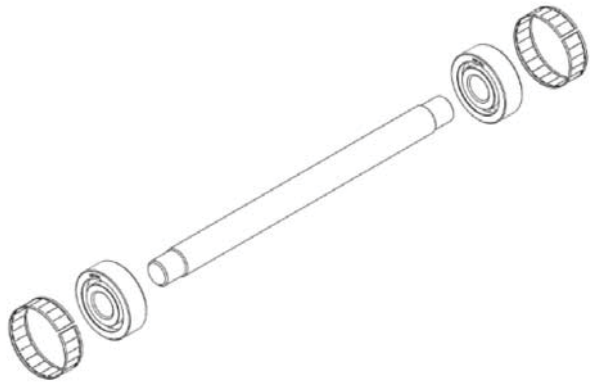

USA Tolerance Rings Mount Bearings

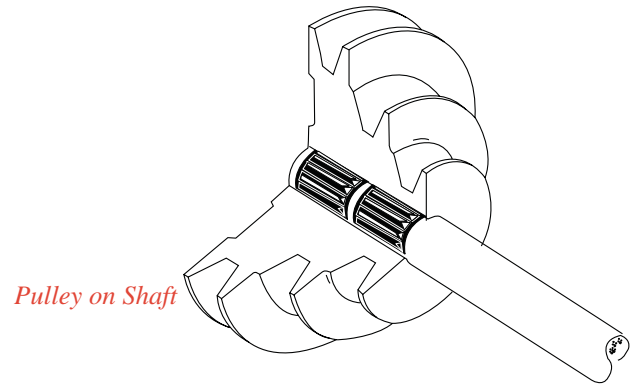

Pulley on Shaft

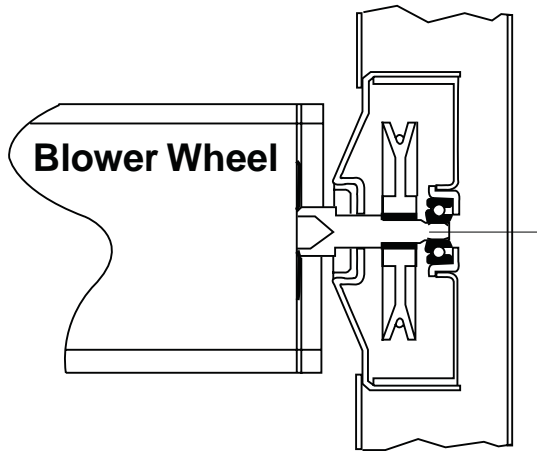

Blower Wheel

USA Tolerance Ring in Ptu Heating/AC Unit

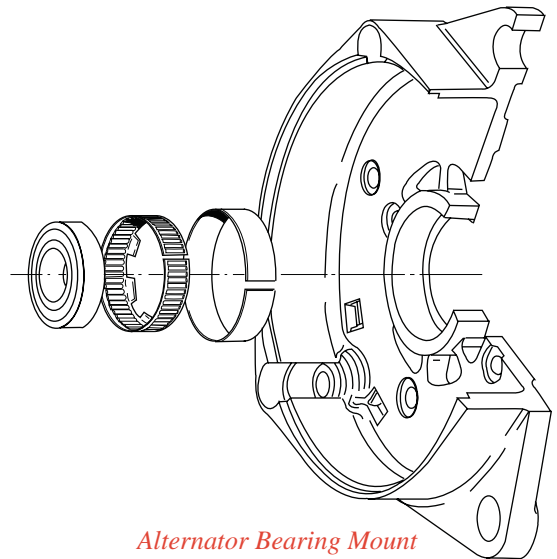

Alternator Bearing Mount

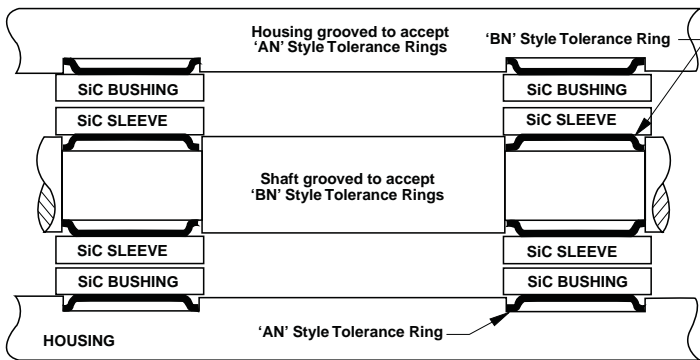

Silicon Carbide Bushing and Sleeve in a Seal-less Chemical pump

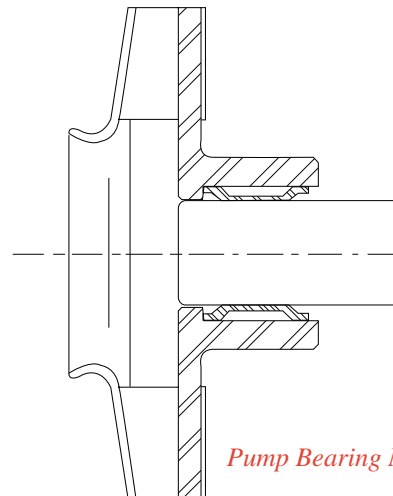

Pump Bearing Mount



USA.
TOLERANCE RINGS

