

EQUILIBAR®

PRECISION FLUID CONTROL

5X MORE
PRECISE
than standard
regulators



Research Series

1/16" – 1/4" Back Pressure Regulators

LOW FLOW, LABORATORY SCALE FOR GAS, LIQUID, & MIXED PHASE SERVICE

5X MORE
PRECISE
than standard
regulators

The Equilibar Difference

OUR PERFORMANCE.

Equilibar® back pressure regulators outperform the competition particularly in applications with low flow rates, mixed phase fluids, corrosive media, or extreme temperatures.

OUR PEOPLE.

Every inquiry gets special attention from our Engineering team to determine the best possible product for your needs. Every back pressure regulator is hand assembled and tested to meet our stringent quality standards.

OUR PRIORITIES.

Our goal is to exceed your expectations. In an industry where delivery times frequently exceed 6 weeks, we offer many of our standard products with delivery in about a week.

Traditional back pressure regulators set the upstream pressure with a spring. These designs utilize sliding seals and other moving parts that can introduce hysteresis and other undesired effects into a process. The Equilibar® back pressure regulator uses a thin, supple diaphragm as the only moving part. This allows frictionless operation without cracking pressure or hysteresis. The accuracy of the Equilibar® back pressure regulator is determined by the accuracy of the pilot setpoint.



How it Works

Simply “load” the Equilibar® back pressure regulator with a pilot pressure equal to your desired back pressure and the Equilibar does the rest. This pressure forces the flexible diaphragm down onto a plate of orifices. A rise in inlet pressure lifts the diaphragm up to allow excess pressure to be relieved through the outlet orifices. Similarly, a loss of pressure at the inlet causes the diaphragm to be pushed closer to the orifices, restricting flow and rebuilding pressure upstream.

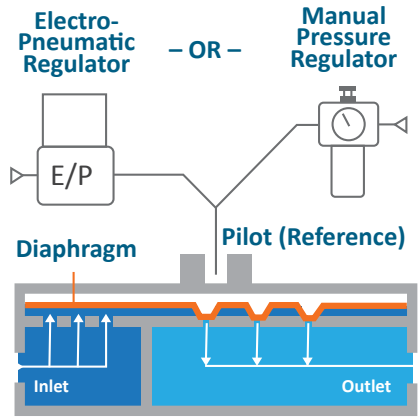

Pilot operate your Equilibar® back pressure regulator with an electronic pressure regulator for automated back pressure control.

Manual and electronic pilot regulators sold separately. For best performance, electronic pilots require the tubing between the outlet of the electronic regulator and the dome of the BPR to have a minimum volume of 2 cubic inches / 35cc.

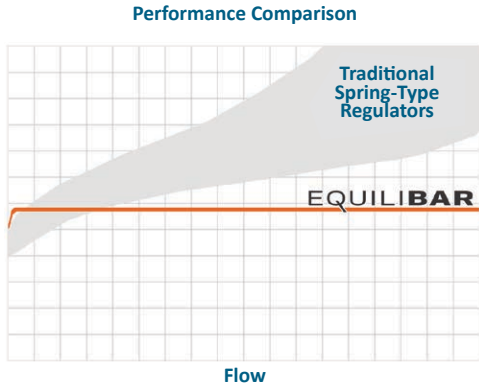

Or set the pilot pressure with a precision pressure reducing regulator for manual control.

TYPE	PRESSURE REDUCING REGULATOR	BACK PRESSURE REGULATOR
SCHEMATIC		
CONTROLS PRESSURE	Downstream	Upstream
OPENS TO	Increase downstream pressure	Decrease upstream pressure
CLOSES TO	Decrease downstream pressure	Increase upstream pressure

BACK PRESSURE REGULATORS VS PRESSURE REDUCING REGULATORS

Pressure reducing regulators reduce a higher supply pressure at the inlet down to a regulated lower pressure at the outlet (downstream). Back pressure regulators work the opposite way. They regulate the inlet (upstream) pressure by opening up only as much as necessary to hold back the desired pressure at the inlet (upstream).

Applications

There are hundreds of potential applications for the unique capabilities of Equilibar back pressure regulators. The Research Series is specifically designed for gas, liquid, and mixed phase applications where precision and consistency are critical.

Equilibar® Research Series regulators are especially useful in processes with low flow rates, extreme high pressures, and other challenging laboratory scenarios. By using unique combinations of diaphragm and O-ring materials, Equilibar regulators are able to perform in the harshest environments, including those with high temperatures and aggressive chemicals.

CATALYST RESEARCH REACTORS

Many catalyst research applications rely on high performance back pressure regulators to maintain stable pressure at elevated temperatures and down to nano flow rates. Because of the Equilibar's unique ability to handle two-phase flow, it is possible to substitute a low-pressure liquid/gas separator for the high-pressure separator.

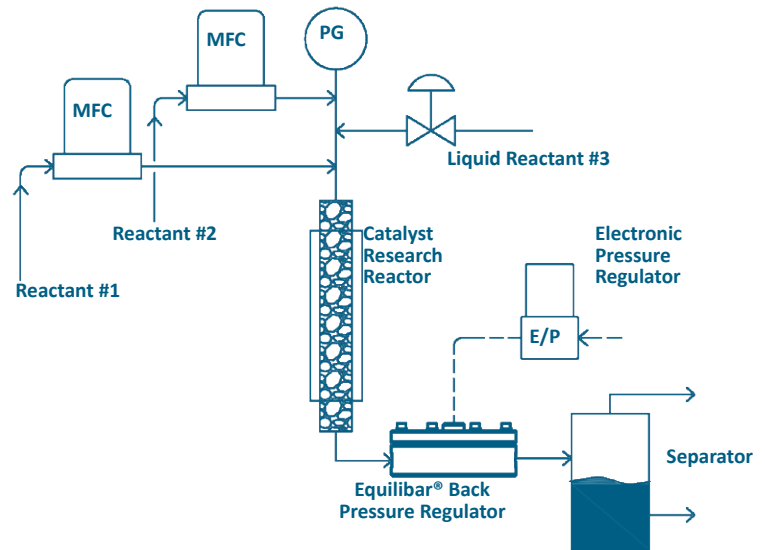

RESERVOIR CORE ANALYSIS

There are many types of upstream petroleum core analysis applications that depend on back pressure regulators to maintain the pressure of the sample. Core flooding (shown below), PVT analysis, pyrolysis, and slim tube analysis can all benefit from the ultra-low flow capability of Equilibar's Research Series. The ZF (Zero Flow) Series in particular was developed to address the demanding requirements of this industry.

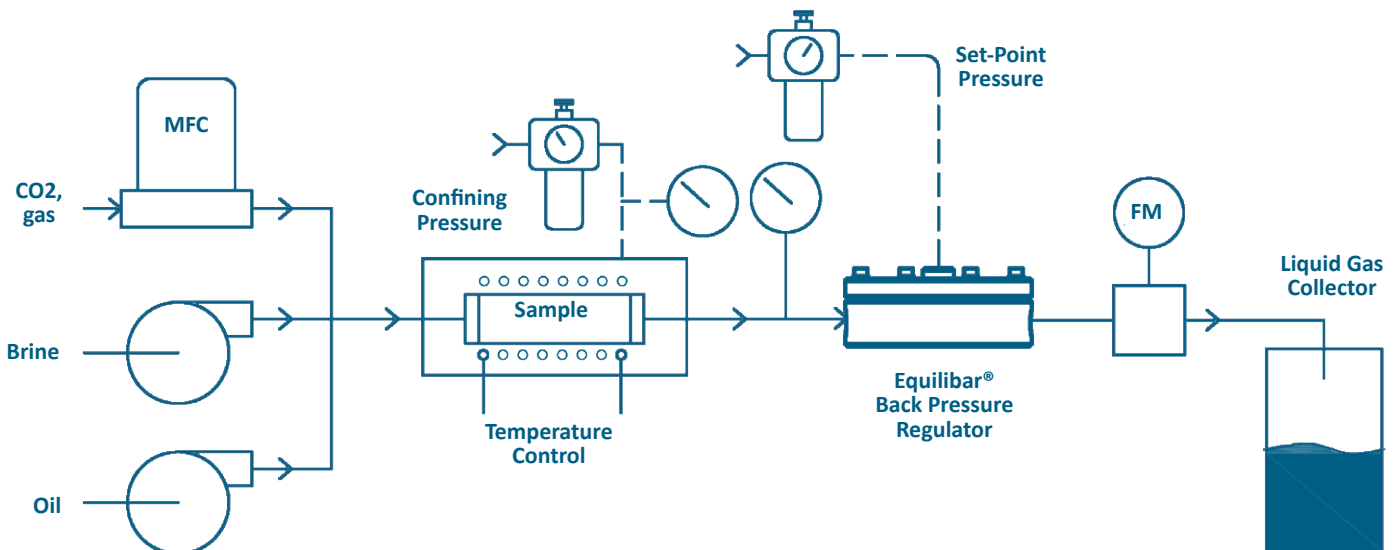

Key Advantages of Equilibar® Back Pressure Regulators

EXTREMELY WIDE RANGE OF CV

Control flow over 100,000:1 turndown ratio. Use just one Equilibar back pressure regulator to replace multiple control valves

HIGH PRESSURE CAPABILITIES

Equilibar Research Series back pressure regulators can operate at pressures up to 10,000 psig / 690 bar(g).

CHEMICAL COMPATIBILITY

Equilibar back pressure regulators are made in many exotic metal alloys and polymers including Hastelloy, Titanium, Zirconium, PTFE, PVDF, with dozens of diaphragm and O-ring options available.

HIGH TEMPERATURE CAPABILITIES

Equilibar Research Series back pressure regulators can be used up to 450C (840F) to allow hot media and/or oven installation.

MULTI-PHASE FLOW COMPATIBILITY

Traditional back pressure regulators consist of a single orifice and valve seat, while Equilibar back pressure regulators have multiple orifices in parallel. This patented multi-orifice design controls liquid and gas flow simultaneously without the pressure spikes seen in traditional regulators. This multi-orifice design allows pressure control of slurries and viscous fluids as well.

INSTANT RESPONSE TIME

Equilibar back pressure regulators instantly respond to changes in either line pressure or set point pressure.

Equilibar Research Series regulators are widely used in catalyst research systems because of their high temperature tolerance, two-phase flow capability, and ease of computer automation. (Photo courtesy Integrated Lab Solutions, GmbH)

RUGGED CONSTRUCTION & EASE OF SERVICE

Equilibar back pressure regulators are machined directly from bar stock metals.

Each Equilibar back pressure regulator consists of just a body, bolts, O-rings, and diaphragm.

Equilibar back pressure regulators can be completely cleaned and rebuilt in minutes. Rebuild kits are always in stock and ready to ship.

FRICTIONLESS OPERATION

Equilibar back pressure regulators are free of springs and valve seats that add friction and reduce precision.

LOW PRESSURE CAPABILITIES

Equilibar's direct diaphragm sealing technology controls down to 0.5 in WC.

COMPUTER AUTOMATION

All Equilibar back pressure regulators can be controlled both manually and electronically. Verify the system design with manual control, then automate it later by adding an electronic pilot regulator

DIRECT CUSTOMER SUPPORT

Contact an [Equilibar application engineer](#) to assist with questions or issues.

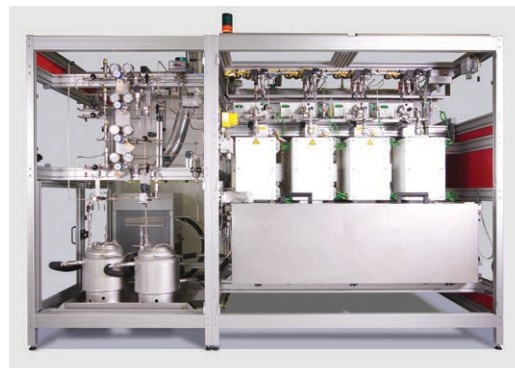

Standard Multi-Orifice Series Back Pressure Regulators

Our unique, patented multi-orifice technology has an extremely wide flow range and superior two phase flow performance.

BASE PART #	MAX PRESSURE RATING PSIG (BAR)	FLOW COEFF. (CV)		INLET/OUTLET PORT SIZE (IN, DN)	REFERENCE PORT SIZE	PORT THREADS		DIM A INCH (MM)	DIM B INCH (MM)	WEIGHT LB (KG)	Dead Volume ¹ mL (in ³)
		MIN	MAX			STANDARD					
STANDARD LOW FLOW MODELS											
LF0	1000 (68)	1E-08	0.01	1/16"	1/8"	V (HPLC)	A, C, N	2.5 (64)	1.5 (39)	1.7 (0.8)	0.23 (0.014)
LF1		1E-08	0.07	1/8" (6)		N (NPT)	A, B, C, O, R, T, V, W	2.5 (64)	1.5 (39)	1.7 (0.8)	2.19 (0.134)
LF2		1E-08	0.07	1/4" (8)				2.5 (64)	1.5 (39)	1.7 (0.8)	3.27 (0.200)
H3P0	3000 (200)	1E-08	0.01	1/16"	1/8"	V (HPLC)	A, C, N	2.5 (64)	1.7 (42)	2.0 (0.9)	0.17 (0.010)
H3P1		1E-08	0.07	1/8" (6)		N (NPT)	A, B, C, O, R, T, V, W	2.5 (64)	1.7 (42)	2.0 (0.9)	2.08 (0.127)
H3P2		1E-08	0.07	1/4" (8)				2.8 (70)	1.7 (42)	2.5 (1.1)	3.48 (0.212)
H6P0	6000 (400)	1E-08	0.01	1/16"	1/8"	V (HPLC)	A, C, N	2.8 (70)	1.7 (42)	2.5 (1.1)	0.17 (0.010)
H6P1		1E-08	0.07	1/8" (6)		N (NPT)	A, B, C, O, R, T, V, W	2.8 (70)	1.7 (42)	2.5 (1.1)	2.18 (0.133)
H6P2		1E-08	0.07	1/4" (8)				2.8 (70)	1.7 (42)	2.5 (1.1)	3.25 (0.198)
H10P1	10,000 (680)	1E-06	0.07	1/8" (6)	1/8"	W	A, C	3.0 (76)	2.1 (53)	3.0 (1.4)	1.28 (0.078)
HIGHER FLOW MODELS											
HF1	1000 (68)	1E-05	0.41	1/8"(6)	1/8"	N (NPT)	A, B, C, O, R, T, V, W	2.5 (64)	1.5 (39)	1.7 (0.8)	5.65 (0.345)
HF2			0.41	1/4" (8)				2.5 (64)	1.5 (39)	1.7 (0.8)	6.68 (0.408)
H3PF2	3000 (200)	1E-05	0.35	1/4" (8)	1/8"	N (NPT)	A, B, C, O, R, T, V, W	2.8 (70)	1.7 (42)	2.5 (1.1)	7.75 (0.473)
H6PF2	6000 (400)		0.35	1/4" (8)				2.8 (70)	1.7 (42)	2.5 (1.1)	6.23 (0.380)
HIGH TEMPERATURE MODELS											
HT1	5000 (345)	1E-05	0.07	1/8" (6)	1/8"	N (NPT)	A, B, C, O, R, T, V, W	3.3 (82)	2.0 (50)	3.5 (1.6)	2.62 (0.160)
HT2			0.07	1/4" (8)				3.8 (95)	2.0 (50)	4.3 (2.0)	3.70 (0.226)
HTF1	5000 (345)	1E-05	0.35	1/8" (6)	1/8"	N (NPT)	A, B, C, O, R, T, V, W	3.8 (95)	2.0 (50)	4.3 (2.0)	8.93 (0.545)
HTF2			0.35	1/4"(8)				3.8 (95)	2.0 (50)	4.3 (2.0)	8.93 (0.545)

¹ Dead volumes are approximate and for reference only. Approximations are made assuming diaphragm is in the "down" position.

PORTING OPTIONS		
Notation	Type	Max Cv
N	NPT (Standard)	Full
A	HiP (High Pressure)	0.072
B	BSPP	Full
C	Custom	-
O	Swagelok VCO [†]	0.072
R	Swagelok VCR [†]	0.072
T	Tube Stub	0.072
V	HPLC	.001 - 0.018
W	Autoclave Speed-Bite	.07

TECHNICAL SPECIFICATIONS	
Max Operating Pressure	Pressure ratings listed in the table are the maximum possible pressure that a unit may be configured to. Units can be configured for optimum performance at lower pressures. Speak with an Application Engineer for more information.
Proof Pressure	150% Rated Pressure ¹
Design Pressure	400% Maximum Body Pressure ²
Temperature Capabilities	Up to 150C (Metal Body, PTFE Diaphragm, Viton [®] O-rings) Up to 200C (Metal Body, Metal Diaphragm, Viton [®] O-rings) Up to 300C (Metal Body, Metal Diaphragm, Kalrez [®] O-rings) Up to 450C (HT/HTF Models, Metal Body, Grafoil Gaskets)

¹All Equilibar units are tested to 150% of their rated pressure prior to shipment.

²Designed according to ASME B31.3, which incorporates an approximate 4X safety factor.

³Polymer units reduce maximum allowable working pressure; consult an application engineer for additional information.

Kalrez[®] is a registered trademark of DuPont. VCO[†] and VCR[†] are trademarks of Swagelok. Grafoil[®] is a trademark of GrafTech.

⚠ Equilibar regulators are control devices, not safety devices or shut-off devices and should not be used as such.

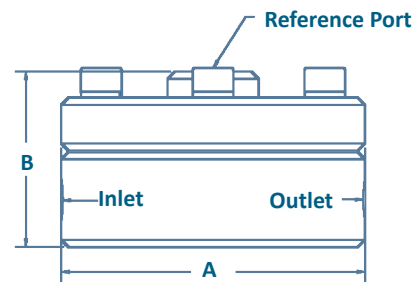

Mounting brackets available for most models. Consult an Application Engineer for mounting information.

WETTED MATERIALS	
Body Material	Stainless Steel 316/316L (standard) Also available: Hastelloy C276, Titanium, Zirconium, PTFE ³ , PVDF ³ , PEEK ³ , PVC ³ , Monel
O-Rings	Viton [®] (FKM) (standard) Also available: FFKM, PTFE, EPDM, Buna-N, Grafoil [®] (HT Only)
Diaphragm	PTFE/Glass Laminate (standard) Also available: Stainless Steel SS316/316L, Hastelloy C276, Virgin PTFE, FKM, Polyimide, Buna-N, PEEK, EPDM

PERFORMANCE¹ OF STANDARD LOW FLOW MODELS (NITROGEN)

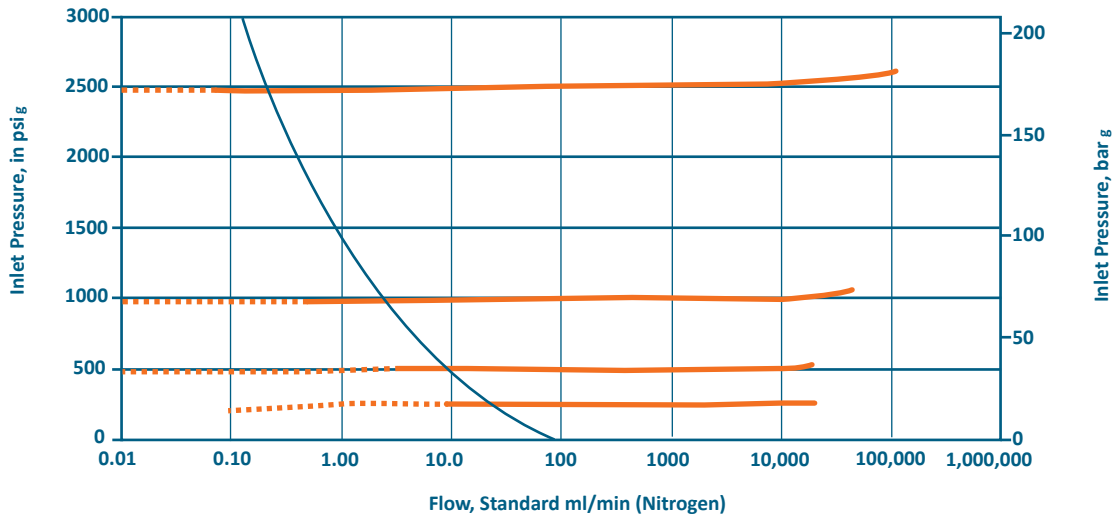

¹Performance below and left of the blue curve is configuration dependent. Higher flow models exhibit similar performance at greater flow capacity. While these performance curves are for nitrogen, Equilibar Back Pressure Regulators may be used for gas, liquid, or mixed phase service.

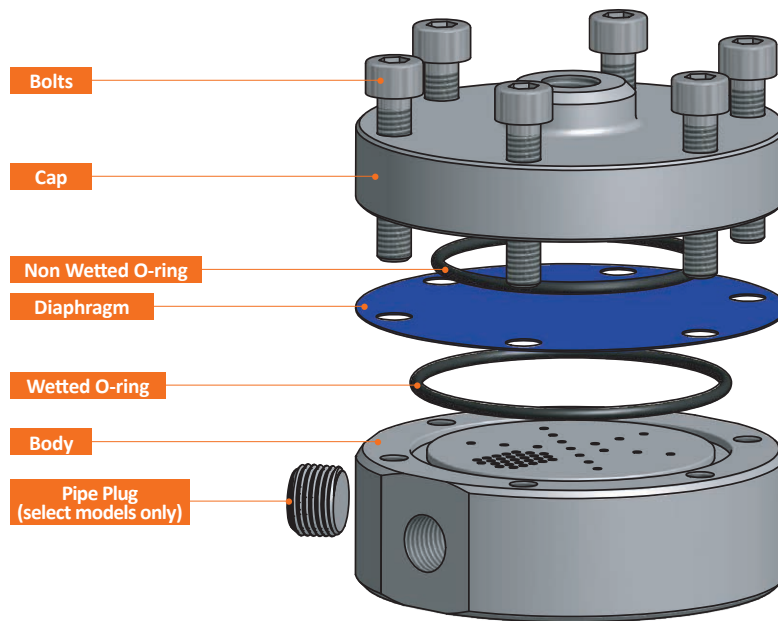

Ultra Low Flow Series Back Pressure Regulators

The Ultra Low Flow Series performs similarly to the Standard Multi-Orifice Series but can operate at lower flow rates.

BASE PART #	MAX PRESSURE RATING PSIG (BAR)	FLOW COEFF. (CV)		INLET/OUTLET PORT SIZE (IN, DN)	REFERENCE PORT SIZE	PORT THREADS		DIM A INCH (MM)	DIM B INCH (MM)	WEIGHT LB (KG)	Dead Volume ¹ mL (in ³)
		MIN	MAX			STANDARD	OPTIONAL				
U3L0	3000 (200)	1E-09	0.01	1/16"	1/8"	V (HPLC)	A, N, C	2.5 (64)	1.7 (42)	2.0 (0.9)	0.25 (0.015)
U3L1		1E-09	0.05	1/8" (6)		N (NPT)	A, B, C, O, R, T, V, W	2.5 (64)	1.7 (42)	2.0 (0.9)	2.16 (0.132)
U3L2		1E-09	0.05	1/4" (8)				2.8 (70)	1.7 (42)	2.5 (1.1)	3.34 (0.204)
U6L0	6000 (400)	1E-09	0.01	1/16"	1/8"	V (HPLC)	A, N, C	2.8 (70)	1.7 (42)	2.5 (1.1)	0.25 (0.015)
U6L1		1E-09	0.05	1/8" (6)		N (NPT)	A, B, C, O, R, T, V, W	2.8 (70)	1.7 (42)	2.5 (1.1)	2.28 (0.139)
U6L2		1E-09	0.05	1/4" (8)				2.8 (70)	1.7 (42)	2.5 (1.1)	3.34 (0.204)
U10L0	10,000 (680)	1E-08	0.01	1/16"	1/8"	V (HPLC)	A, N, C	3.0 (76)	2.1 (53)	3.0 (1.4)	3.34 (0.204)
U10L1		1E-08	0.05	1/8" (6)		N (NPT)	A, C, W	3.0 (76)	2.1 (53)	3.0 (1.4)	1.33 (0.081)
HIGH TEMPERATURE MODELS²											
ULHT1	5000 (345)	1E-09	0.05	1/8" (6)	1/8"	N (NPT)	A, B, C, O, R, T, V, W	3.3 (84)	2.0 (51)	4.5 (2.0)	2.44 (.149)
ULHT2		1E-09	0.05	1/4" (8)				3.8 (96)	2.0 (51)	5.2 (2.4)	3.54 (.216)

¹ Dead volumes are approximate and for reference only. Approximations are made assuming diaphragm is in the "down" position.
² ULHT models are for ultra low flow / high temperature applications up to 450C with specific gaskets and diaphragm.

PORTING OPTIONS		
Notation	Type	Max Cv
N	NPT (Standard)	Full
A	HiP (High Pressure)	Full
B	BSPP	Full
C	Custom	-
O	Swagelok VCO*	Full
R	Swagelok VCR*	Full
T	Tube Stub	Full
V	HPLC	.001 - 0.018
W	Autoclave Speed-Bite W125	Full

TECHNICAL SPECIFICATIONS	
Max Operating Pressure	Pressure ratings listed in the table are the maximum possible pressure that a unit may be configured to. Units can be configured for optimum performance at lower pressures. Speak with an Application Engineer for more information.
Proof Pressure	150% Rated Pressure ¹
Design Pressure	400% Maximum Body Pressure ²
Temperature Rating	150C (Metal Body, PTFE Diaphragm, Viton® O-rings) 200C (Metal Body, Metal Diaphragm, Viton® O-rings) 300C (Metal Body, Metal Diaphragm, FFKM O-rings) Up to 450C (ULHT Models, Metal Body, Grafoil Gaskets)

Performance⁴ of Ultra Low Flow Series (Nitrogen)

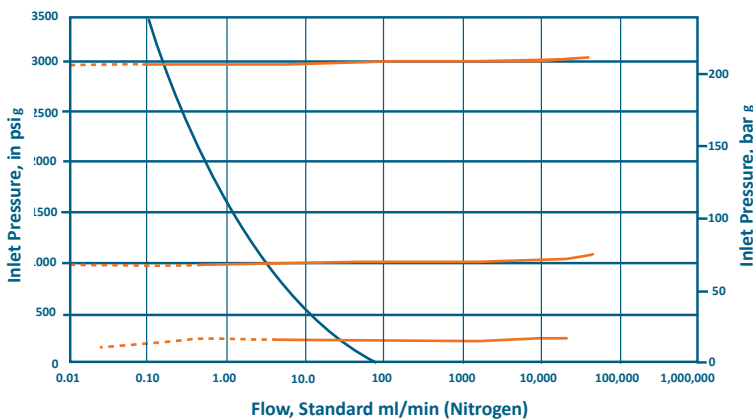

⁴ Performance below and left of the blue curve is configuration dependent. While the above curves are for nitrogen, Equilibar Back Pressure Regulators may be used for gas, liquid, or mixed phase fluids.

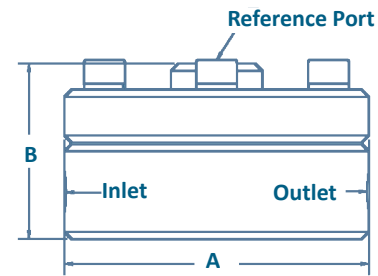

Mounting brackets available for most models. Consult an application engineer for mounting information.

WETTED MATERIALS	
Body Material	Stainless Steel 316/316L (standard) Also available: Hastelloy C276, Titanium, Zirconium, PTFE ³ , PVDF ³ , PEEK ³ , PVC ³ , Monel
O-Rings	Viton® (FKM) (standard) Also available: FFKM, PTFE, EPDM, Buna-N
Diaphragm	PTFE/Glass Laminate (standard) Also available: Stainless Steel SS316/316L, Hastelloy C276, Virgin PTFE, FKM, Polyimide, Buna-N, PEEK, EPDM

¹ All Equilibar units are tested to 150% of their rated pressure prior to shipment.
² Designed according to ASME B31.3, which incorporates an approximate 4X safety factor.
³ Polymer units reduce maximum allowable working pressure, consult an application engineer for additional information.

Viton® and Kalrez® are registered trademarks of DuPont. VCO® and VCR® are trademarks of Swagelok.

△ Equilibar regulators are control devices, not safety devices or shut-off devices and should not be used as such.

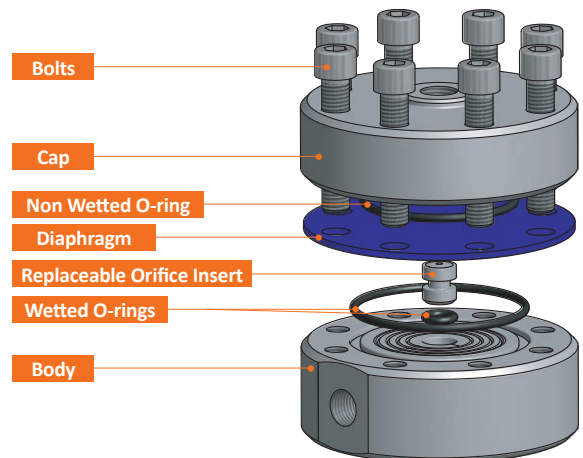

Zero Flow Series Back Pressure Regulator

Operates similarly to the Standard Multi-Orifice design, but utilizes a soft-seat to provide effective zero flow pressure control.

BASE PART #	MAX PRESSURE RATING PSIG (BAR)	FLOW COEFF. (CV)		INLET/OUTLET PORT SIZE (IN, DN)	REFERENCE PORT SIZE	PORT THREADS		DIM A INCH (MM)	DIM B INCH (MM)	WEIGHT LB (KG)	Dead Volume ¹
		MIN	MAX			STANDARD	OPTIONAL				mL (in ³)
ZF0	3000 (200)	0	0.015	1/16"	1/8"	V (HPLC)	A, C, N	2.5 (64)	1.7 (42)	2.0 (0.9)	0.25 (0.02)
ZF1	3000 (200)	0		1/8" (6)	1/8"	N (NPT)	A, B, C, O, R, T, V, W	2.5 (64)	1.7 (42)	2.0 (0.9)	2.16 (0.13)

¹ Dead volumes are approximate and for reference only. Approximations are made assuming diaphragm is in the "down" position. Speak with an Application Engineer to find out if the Zero Flow Series is right for your application.

PORTING OPTIONS		
Notation	Type	Max Cv
N	NPT (Standard)	Full
A	HiP (High Pressure)	Full
B	BSPP	Full
C	Custom	-
O	Swagelok VCO [*]	Full
R	Swagelok VCR [*]	Full
T	Tube Stub	Full
V	HPLC	.001 - 0.018
W	Autoclave Speed-Bite W125	Full

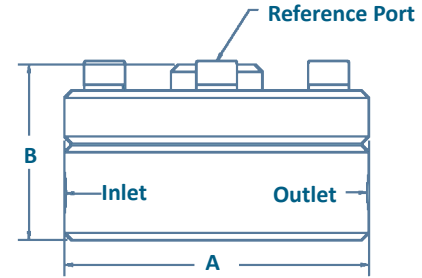

Mounting brackets available for most models. Consult an Application Engineer for mounting information.

TECHNICAL SPECIFICATIONS	
Max Operating Pressure	Pressure ratings listed in the table are the maximum possible pressure that a unit may be configured to. Units can be configured for optimum performance at lower pressures. Speak with an Application Engineer for more information.
Proof Pressure	150% Rated Pressure ¹
Design Pressure	400% Maximum Body Pressure ²
Temperature Rating	200C (Metal Body, Metal diaphragm, Viton [®] O-rings) 300C (Metal Body, Metal Diaphragm, FFKM O-rings)

WETTED MATERIALS	
Body Material	Stainless Steel 316/316L (standard) Also available: Hastelloy C276, Titanium, Zirconium, PTFE ³ , PVDF ³ , PEEK ³ , PVC ³ , Monel
O-Rings	Viton [®] (FKM) (standard) Also available: FFKM, PTFE, EPDM, Buna-N (Nitrile)
Diaphragm	Stainless Steel SS316/316L (standard) Also available: Hastelloy C276, PTFE/Glass Laminate, Virgin PTFE, FKM, Polyimide, Buna-N, (Nitrile) PEEK, EPDM

¹All Equilbar units are tested to 150% of their rated pressure prior to shipment.

²Designed according to ASME B31.3, which incorporates an approximate 4X safety factor.

³Polymer units reduce maximum allowable working pressure, consult an application engineer for additional information.

Viton[®] is a registered trademark of DuPont. VCO[®] and VCR[®] are trademarks of Swagelok.

⚠ Equilbar regulators are control devices, not safety devices or shut-off devices and should not be used as such.

Performance of Zero Flow Series (Nitrogen)⁴

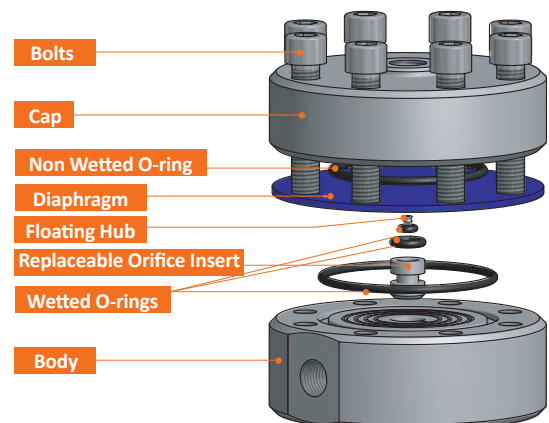
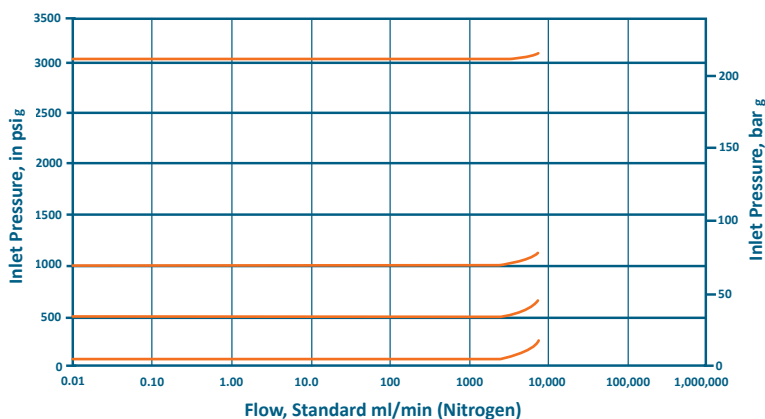

⁴While these performance curves are for nitrogen, Equilbar Back Pressure Regulators may be used for gas, liquid, or mixed phase service.

Research Series Part Number Key

This part number key explains our part numbering system and possible model options. All of our BPRs are custom-configured by our engineers based on the customer's specific application parameters (process fluid, pressures, flow rates, temperature, etc.). Our engineers request process operating parameters in order to build and quote a full part number for a suitable regulator. This chart is a reference to help understand the chosen part number

EXAMPLE																				
LF	1	S	N	N	X	-	N	S	X	P	500	T	150	G	X	V	V		B	
				N	X	-			X	P		T			X					
1	2	3	4	5	6	-	7	8	9		10		11	12	13	14	15	16	17	18

<p>1 Model Up to 1000 psig LF Cv: 1E-8 to 0.07 HF Cv: 1E-5 to 0.41</p> <p>Up to 3000 psig U3L Cv: 1E-9 to 0.05 H3P Cv: 1E-8 to 0.07 H3PF Cv: 1E-5 to 0.35</p> <p>Up to 6000 psig U6L Cv: 1E-9 to 0.05 H6P Cv: 1E-8 to 0.07 H6PF Cv: 1E-5 to 0.35</p> <p>Up to 10,000 psig U10L Cv: 1E-6 to 0.05 H10P Cv: 1E-6 to 0.07 H10PF Cv: 1E-4 to 0.35</p> <p>Specialty Regulators HT High Temperature ZF Zero-Flow</p> <p>2 Port Size 0 1/16" HPLC 1 1/8" DN (6) 2 1/4" DN (8)</p> <p>3 Body Material S Stainless Steel 316/316L H Hastelloy C276 T Titanium Z Zirconium F PTFE K PEEK D PVDF</p> <p>4 Port Threads N NPT B BSPP W Autoclave Speed-Bite O VCO* R VCR* V HPLC A HiP</p> <p>5 Recess N None</p>	<p>6 Mod # X (Factory Selected)</p> <p>7 Reference Port Threads N NPT B BSPP W Autoclave Speed-Bite O VCO* R VCR* V HPLC A HiP</p> <p>8 Cap Material (Non Wetted) S Stainless Steel 316/316L P PVC F PTFE K PEEK D PVDF</p> <p>9 Bolts X (Factory Selected)</p> <p>10 Pressure Rating (psig) <i>This is the maximum pressure you would like your unit to be configured to accept. Must be equal to or less than the maximum body pressure (in psig)</i></p> <p>11 Temperature Rating <i>Temperature Limitations: 40C for most polymer bodies 150C for most PTFE diaphragms 200C for Viton O-rings 300C for FFKM O-rings</i></p> <p>12 Diaphragm Material G PTFE (Glass Reinforced) B Buna-N (Nitrile) V FKM Fluoroelastomer M EPDM E Polyethylene F PTFE (Virgin) S Stainless Steel 316/316L H Hastelloy C276 I Polyimide K PEEK L Kel-F C FEP</p> <p>13 Diaphragm Thickness (Factory Selected)</p>	<p>14 O-ring (Wetted) V Viton® FKM Shore 75 W Viton® FKM Shore 90 K Kalrez® FFKM Grade 7075 L Kalrez® FFKM Grade 7090 Z Markez® FFKM (# varies by grade) F PTFE Grade 55 E EPDM Grade 70 B Buna-N Grade 70 (Nitrile) G Grafoil (HT Only)</p> <p>15 O-ring (Non Wetted) V Viton® FKM Shore 75 W Viton® FKM Shore 90 K Kalrez® FFKM Grade 7075 L Kalrez® FFKM Grade 7090 Z Markez® FFKM (# varies by grade) F PTFE Grade 55 E EPDM Grade 70 B Buna-N Grade 70 (Nitrile) G Grafoil® (HT Only)</p> <p>16 O-ring (Wetted) U3L, U6L, U10L, ZF Only Leave blank for all other models (Blank) None V Viton® FKM Shore 75 W Viton® FKM Shore 90 K Kalrez® FFKM Grade 7075 L Kalrez® FFKM Grade 7090 Z Markez® FFKM (# varies by grade) E EPDM Grade 70 B Buna-N Grade 70 (Nitrile)</p> <p>17 O-ring (Wetted) ZF Only Leave blank for all other models (Blank) None V Viton® FKM Shore 75 W Viton® FKM Shore 90 K Kalrez® FFKM Grade 7075 L Kalrez® FFKM Grade 7090 Z Markez® FFKM (# varies by grade) E EPDM Grade 70 B Buna-N Grade 70 (Nitrile)</p> <p>18 Special Options (Blank) None B Mounting Bracket O Oxygen Cleaning</p>
---	---	---

Options listed in blue are typically in stock for quick shipment.
For custom options [contact an applications engineer](#).

Viton® and Kalrez® are registered trademarks of DuPont. VCO® and VCR® are trademarks of Swagelok. Grafoil® is a trademark of GrafTech. Markez® is trademark of Marco Rubber & Plastic.